

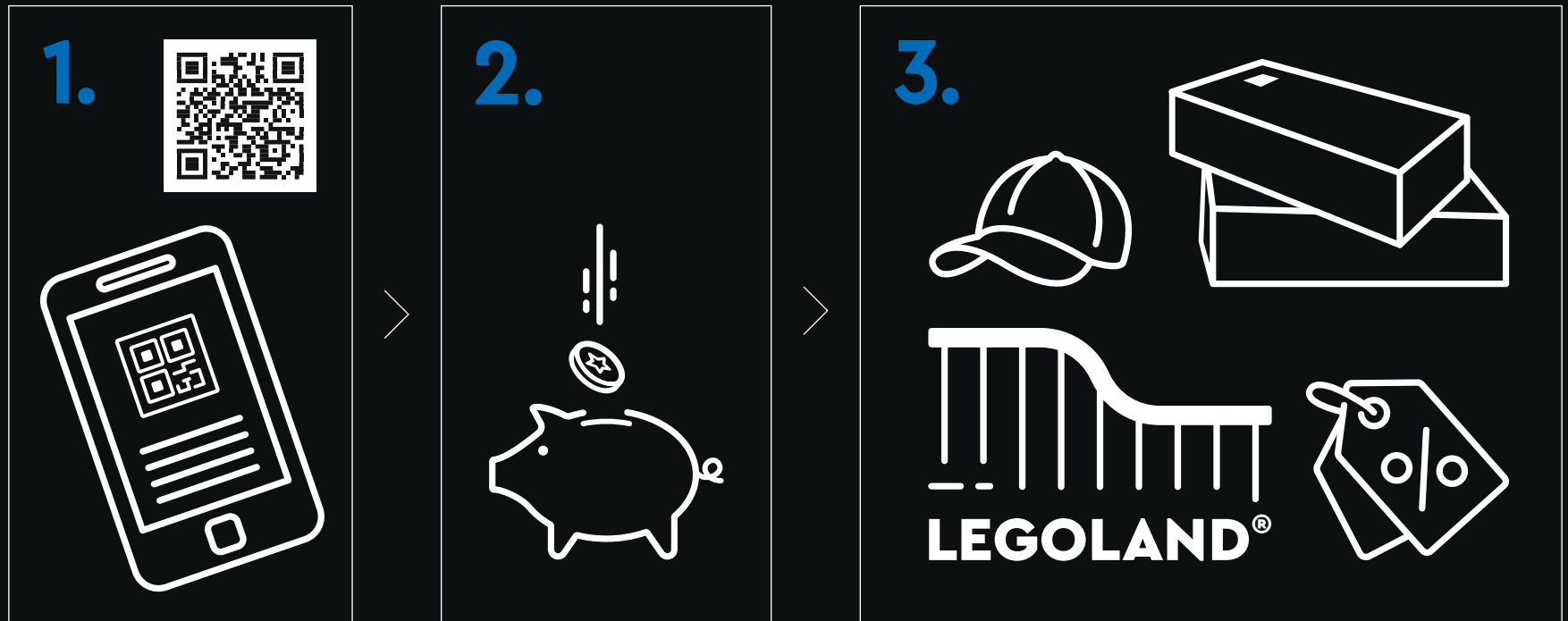



LEGO.com/sustainable-packaging

LEGO® VIP



1. Sign up **2.** Earn points for purchases **3.** Redeem points for rewards, experiences, discounts & more | **1.** Melde dich an **2.** Sammle Punkte bei jedem Kauf **3.** Löse die Punkte für Belohnungen, Erlebnisse, Rabatte und Ähnliches ein | **1.** Inscrivez-vous **2.** Gagnez des points lors de vos achats **3.** Échangez vos points contre des récompenses, des expériences, des remises et bien plus encore | **1.** Iscriviti **2.** Guadagna punti con i tuoi acquisti **3.** Riscatta punti per premi, esperienze, sconti e altro ancora | **1.** Regístrate **2.** Gana puntos por tus compras **3.** Canjea puntos por recompensas, experiencias, descuentos y mucho más | **1.** Registe-se **2.** Ganhe pontos em compras **3.** Troque os pontos para prémios, experiências, descontos e muito mais | **1.** 注册 **2.** 购物赚积分 **3.** 用积分兑换奖励、体验、折扣等 | **1.** Zarejestruj się **2.** Zdobywaj punkty za zakupy **3.** Wymieniaj punkty na rabaty, przygody i inne nagrody | **1.** Zaregistrujte se **2.** Sbírejte body za nákupy **3.** Vyměňujte body za odměny, zážitky, slevy a spoustu dalšího | **1.** Zaregistrujte se **2.** Získavajte body za nákupy **3.** Uplatnite si body a získajte odmeny, rôzne zážitky, zľavy a ešte viac | **1.** Regisztrálj **2.** Szerezz pontokat minden vásárlással **3.** Váltsd be pontjaidat jutalmakra, élményekre, kedvezményekre és egyebekre | **1.** Înscric-te **2.** Câștigă puncte pentru achiziții **3.** Valorifică puncte pentru recompense, experiențe, reduceri și multe altele | **1.** Регистрируйте се **2.** Получайте точки за покупки **3.** Используйте точки за награды, услуги, отстъпки и т.н. | **1.** Reģistrējies **2.** Pelni punktus par pirkumiem **3.** Izmanto punktus, lai saņemtu balvas, izklaides iespējas, atlaides un daudz ko citu | **1.** Registreeru **2.** Teeni ostude eest punkte **3.** Lunasta punktide eest preemiad, elamused, allahindlused ja muu | **1.** Užsiregistruokite **2.** Pelnykite taškus už pirkinius **3.** Panaudokite taškus atlygiui, funkcijoms, nuolaidoms ir ne tik





姫路城

EL CASTILLO DE HIMEJI / EL CASTILLO DE LA GARZA BLANCA

Con sus majestuosas vistas de la ciudad japonesa de Himeji, el impresionante Castillo de Himeji es una joya arquitectónica declarada Patrimonio de la Humanidad por la UNESCO. Construido como fortaleza en 1333, hacia el final de una época de guerras civiles, el castillo ha atravesado varias transformaciones a lo largo de los siglos. En 1600 se emprendió una gran reconstrucción que dio lugar a la estructura actual, conservada íntegramente hasta nuestros días, en un primer momento bajo el mando de los señores feudales y, más adelante, gestionada por el gobierno japonés. Laberintos de enrevesados senderos diseñados antaño para confundir y atrapar al enemigo tejen ahora un intrigante viaje para el visitante. Superviviente de guerras, terremotos, incendios y tiempos de paz, el Castillo de la Garza Blanca se erige como un sereno monumento a la cultura japonesa. Descubre los complejos detalles de la torre principal y la historia del castillo mientras construyes.

CHRIS MCVEIGH
Diseñador sénior de LEGO®

UN TRIBUTO A UN VENERADO MONUMENTO

🍷 "En 2023 se cumplen 30 años de la declaración del Castillo de Himeji como Patrimonio de la Humanidad por la UNESCO, y su arquitectura e historia siguen siendo una especie de misterio por descifrar. Creamos la torre principal como punto focal natural y jugamos con las proporciones y las escalas para que destacara. Si has visitado el castillo, puede que reconozcas algunos de sus interiores. Si no lo has conocido en persona, esperamos que despierte tu imaginación y curiosidad".





Sigue algunos de los enrevesados caminos, rampas y escaleras que recorren el castillo.



UNA ILUSIÓN ÓPTICA

El método de techado del Castillo de Himeji emplea tejas negras rectangulares y semicirculares entrelazadas. Varias capas de arcilla blanca recubren las tejas, dando a la cubierta un aspecto de malla de alto contraste cuando se observa de cerca. Sin embargo, a distancia, el dibujo de la malla adopta el color gris. Las tejas de este set son de color gris piedra oscuro para reflejar el envejecimiento de las tejas.



Echa un vistazo al interior del modelo después de construirlo.



Cada torre se construye de forma diferente e incluso tienen alturas distintas.



Los ángulos irregulares predominan en todo el castillo y las murallas.

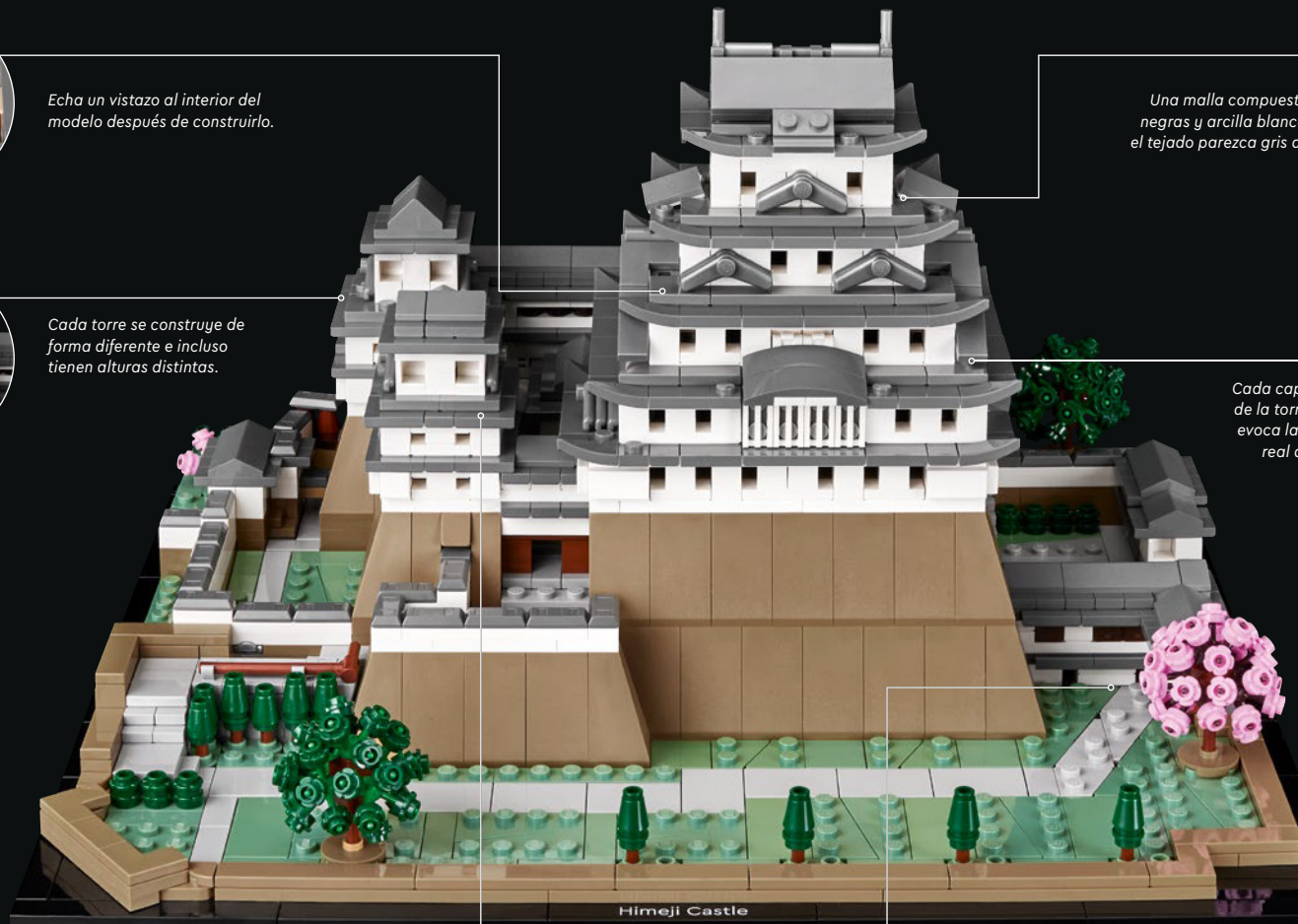

Una malla compuesta por tejas negras y arcilla blanca hace que el tejado parezca gris desde lejos.

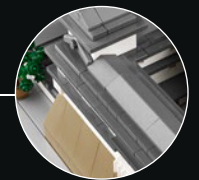
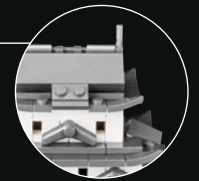

Cada capa o planta de la torre principal evoca la estructura real del castillo.



Decora los cerezos con flores rosas u hojas verdes.

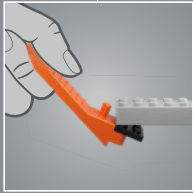
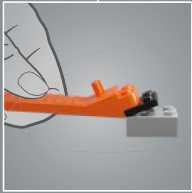
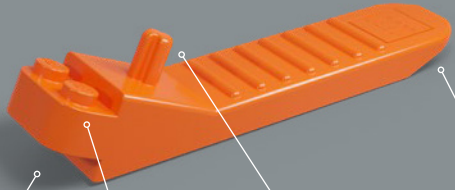

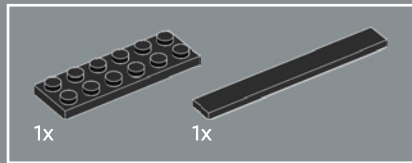

1

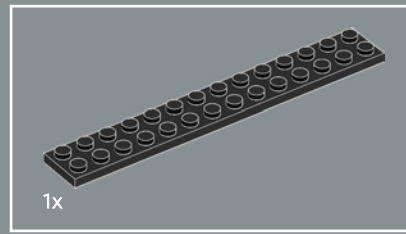
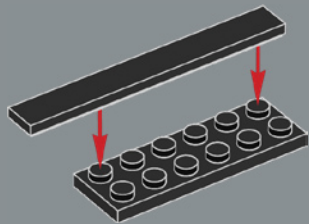

2

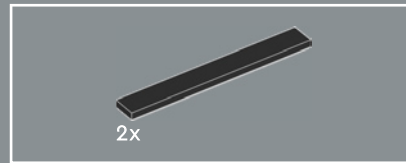
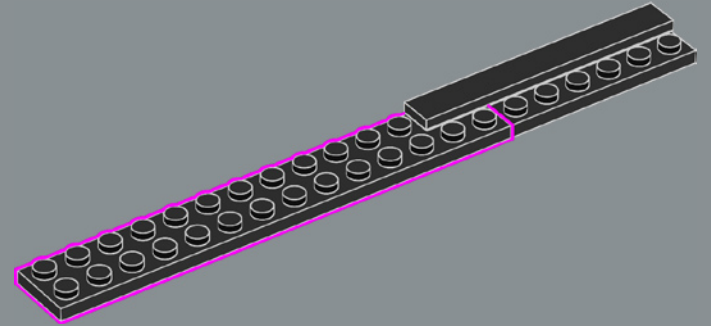

3

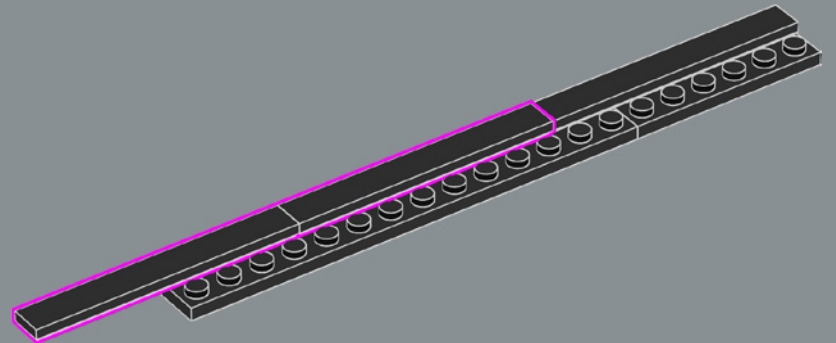

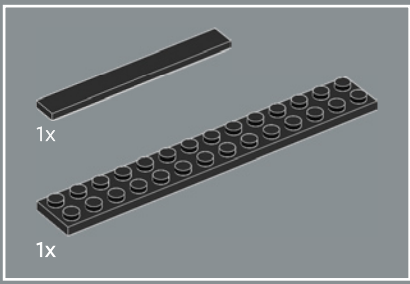

4

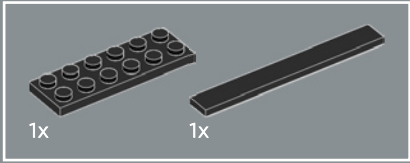
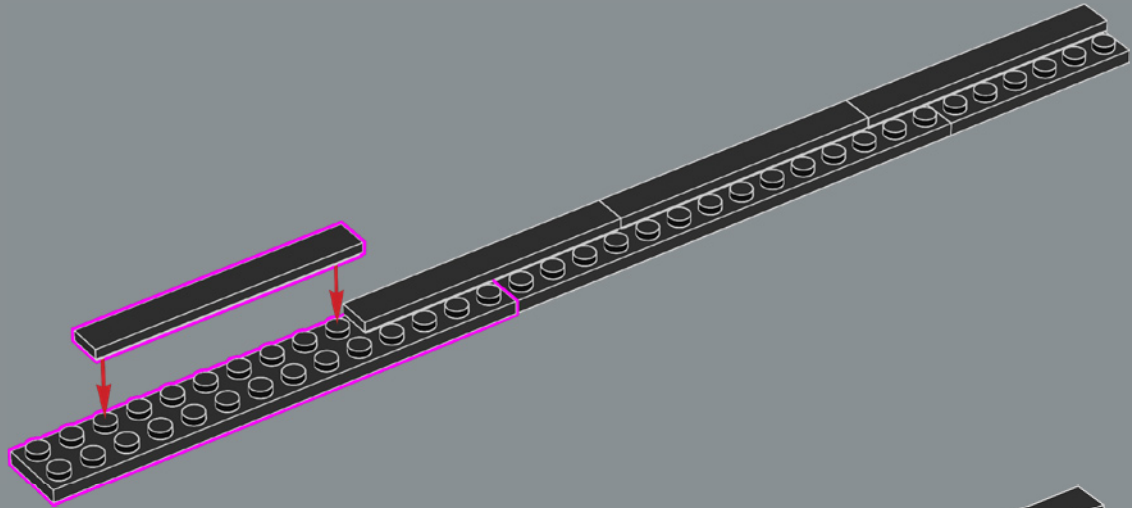

5

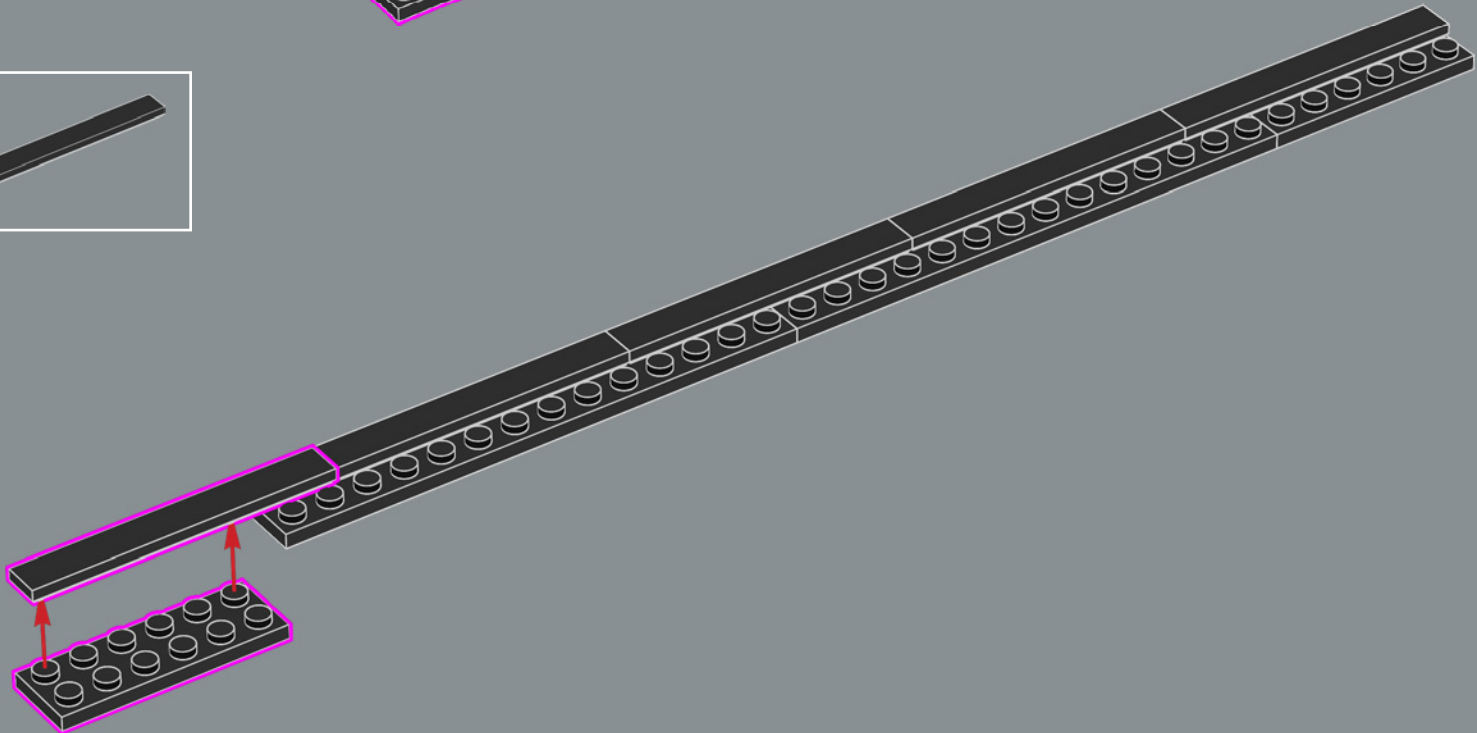

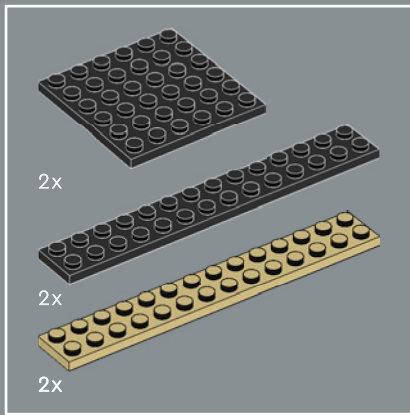

6

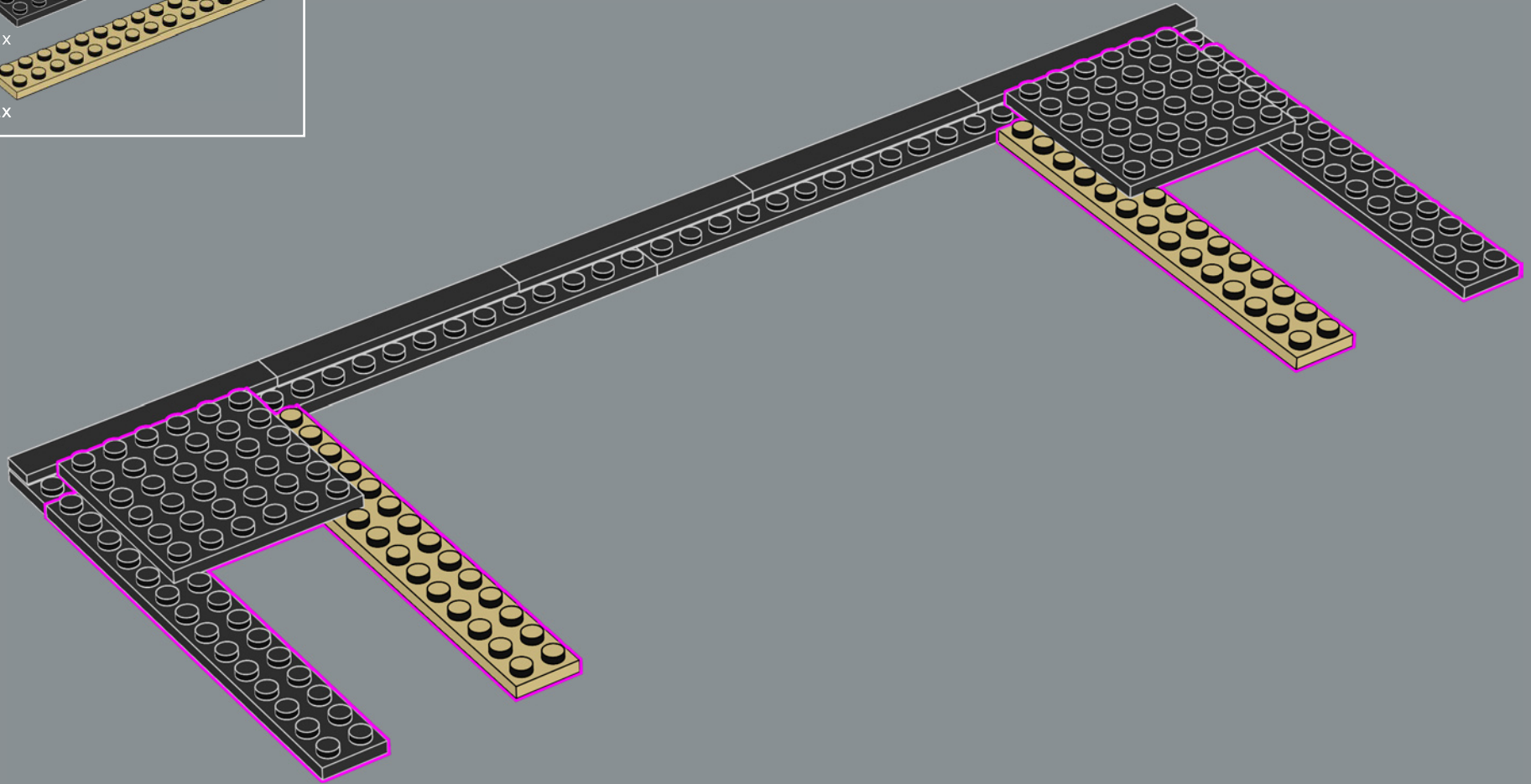

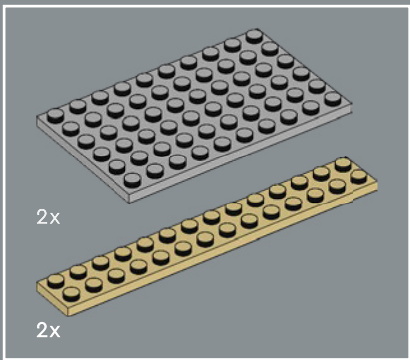

7

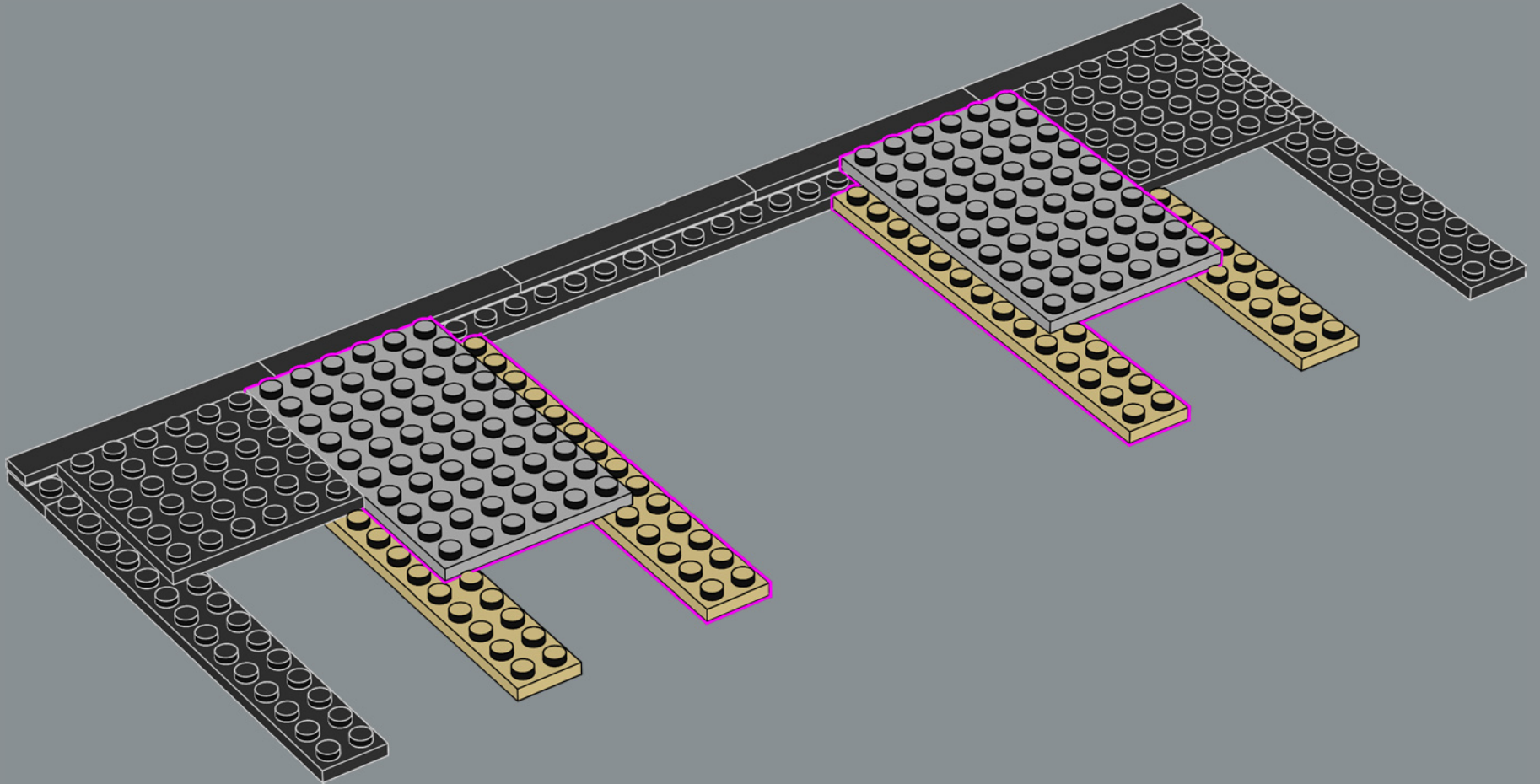

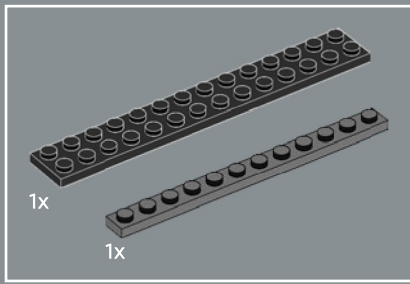

8

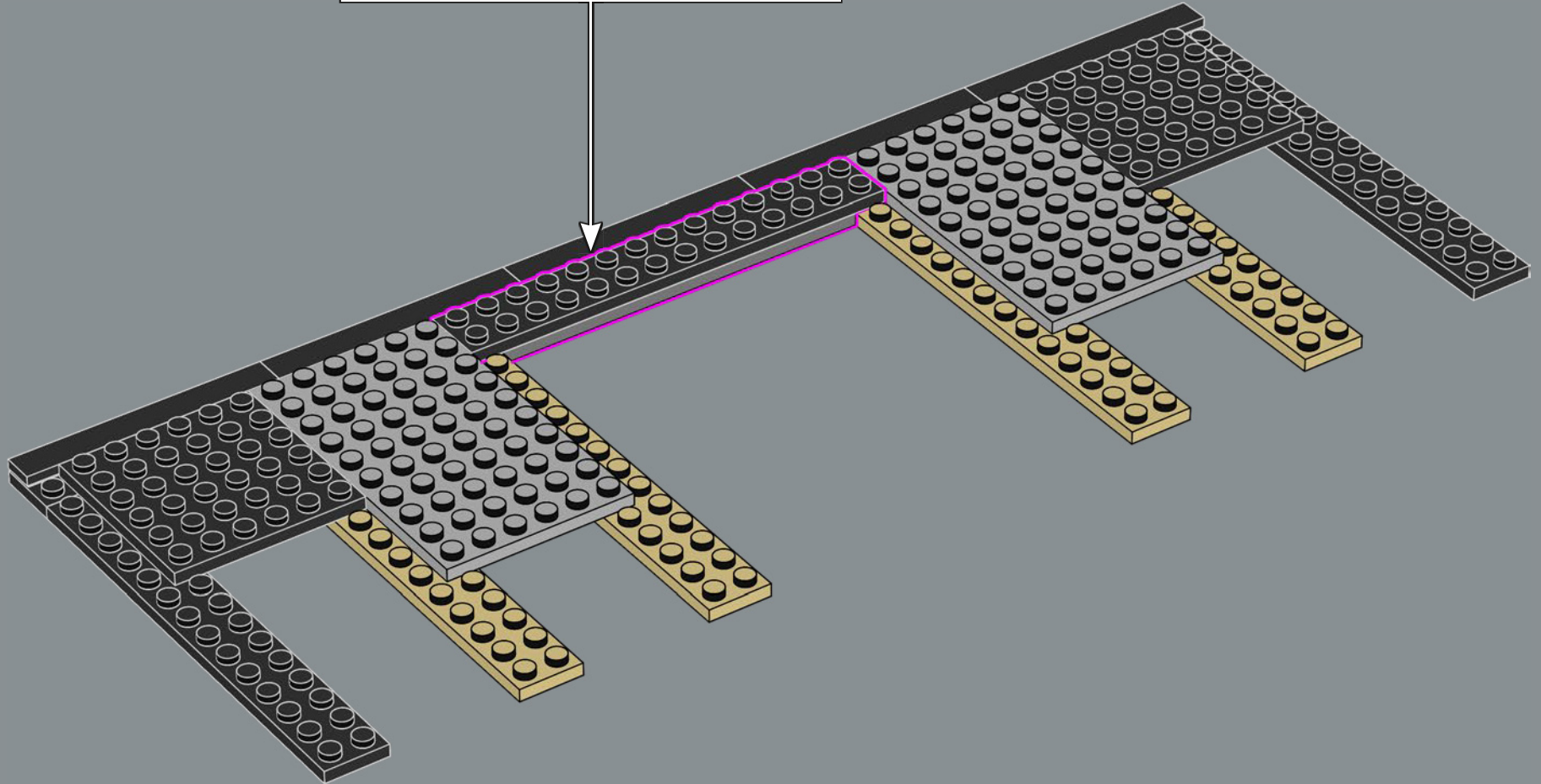
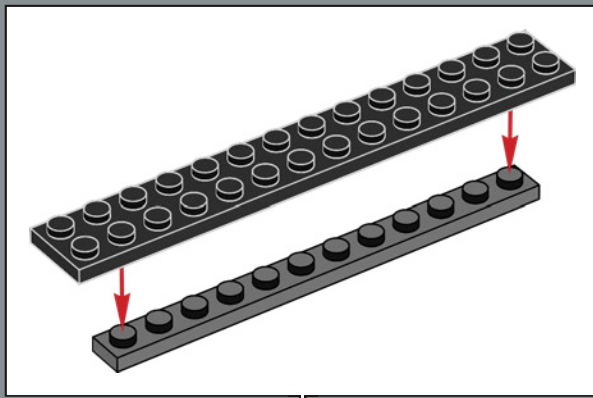

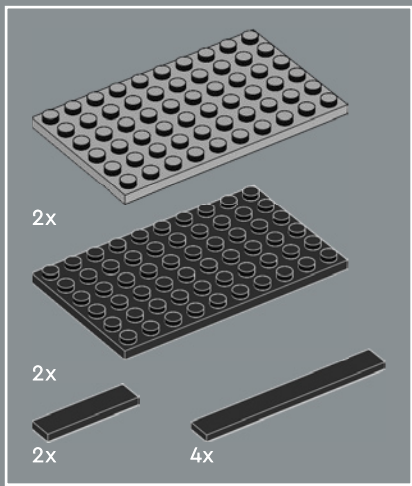

9

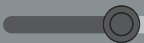
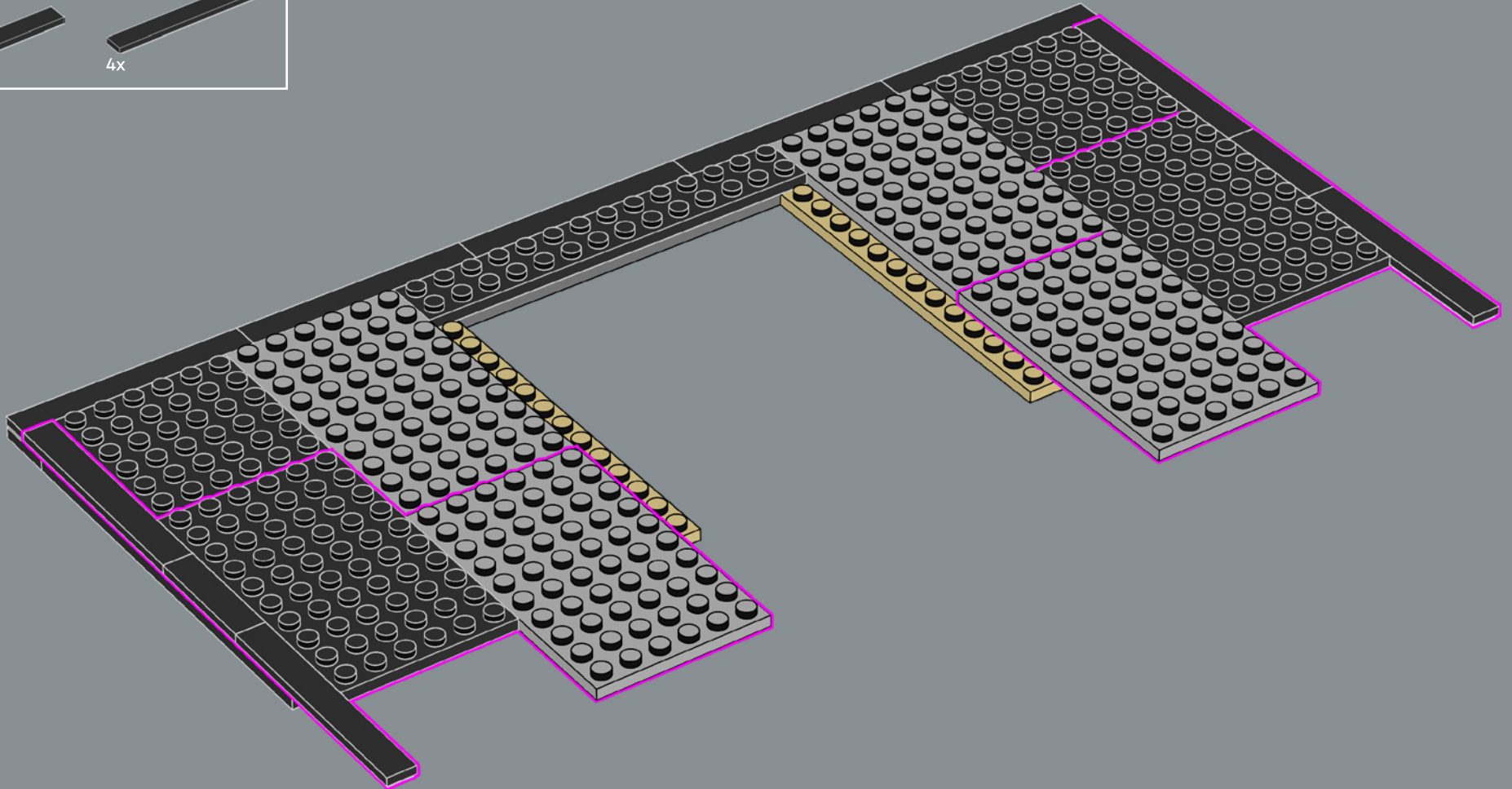

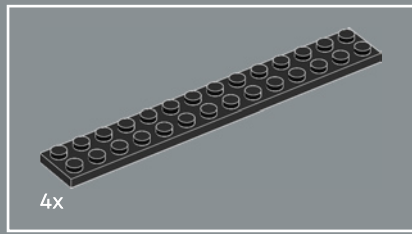

10

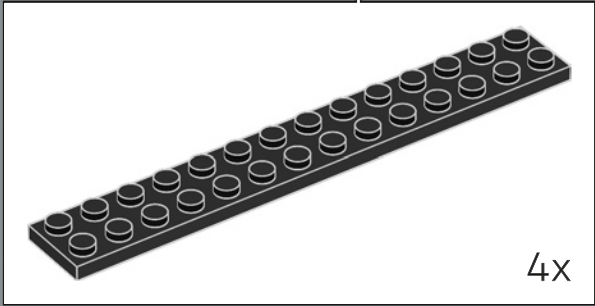
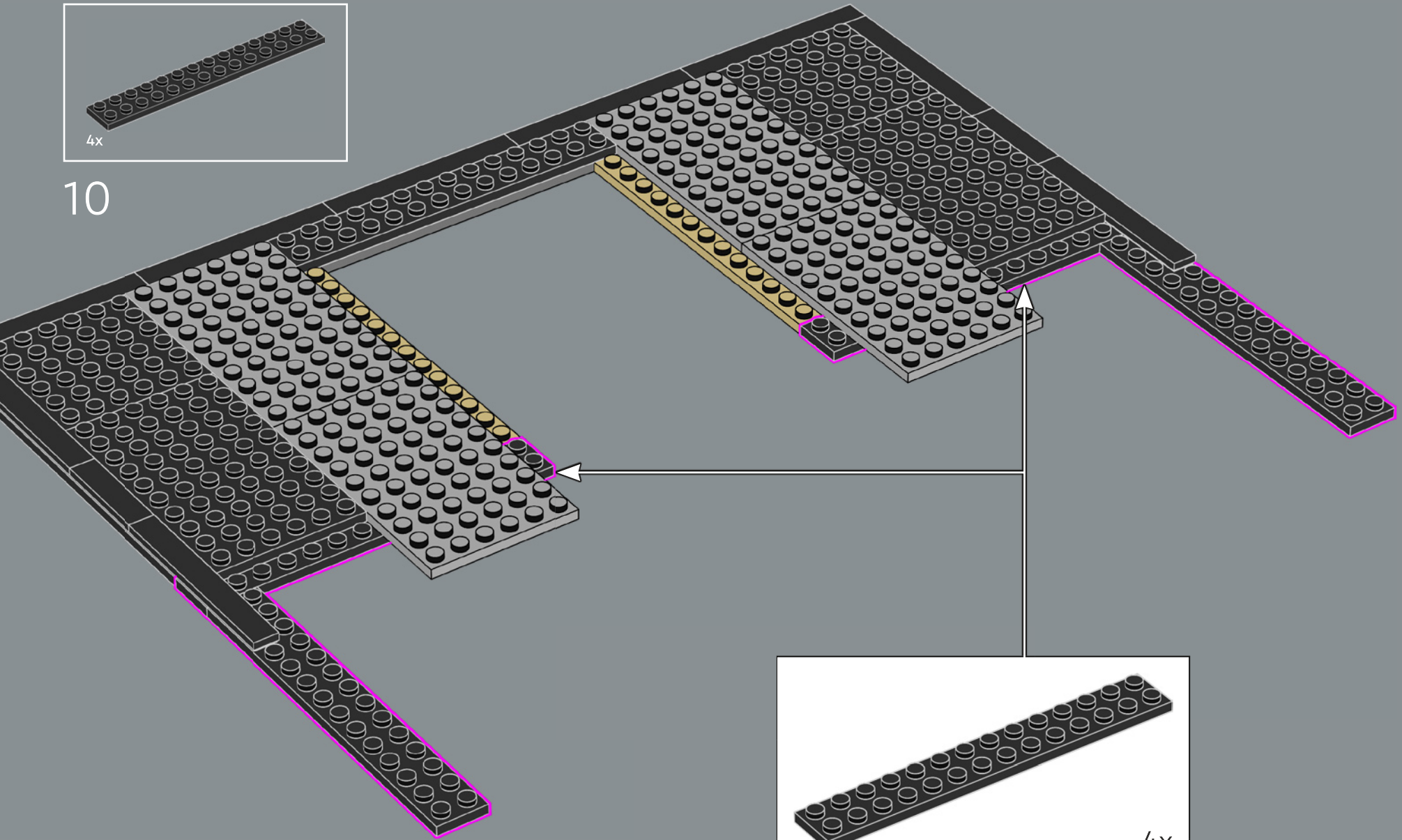

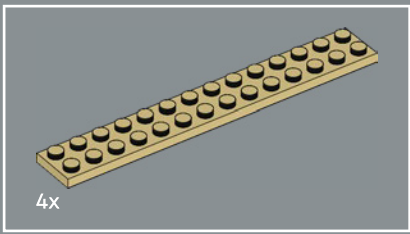

11

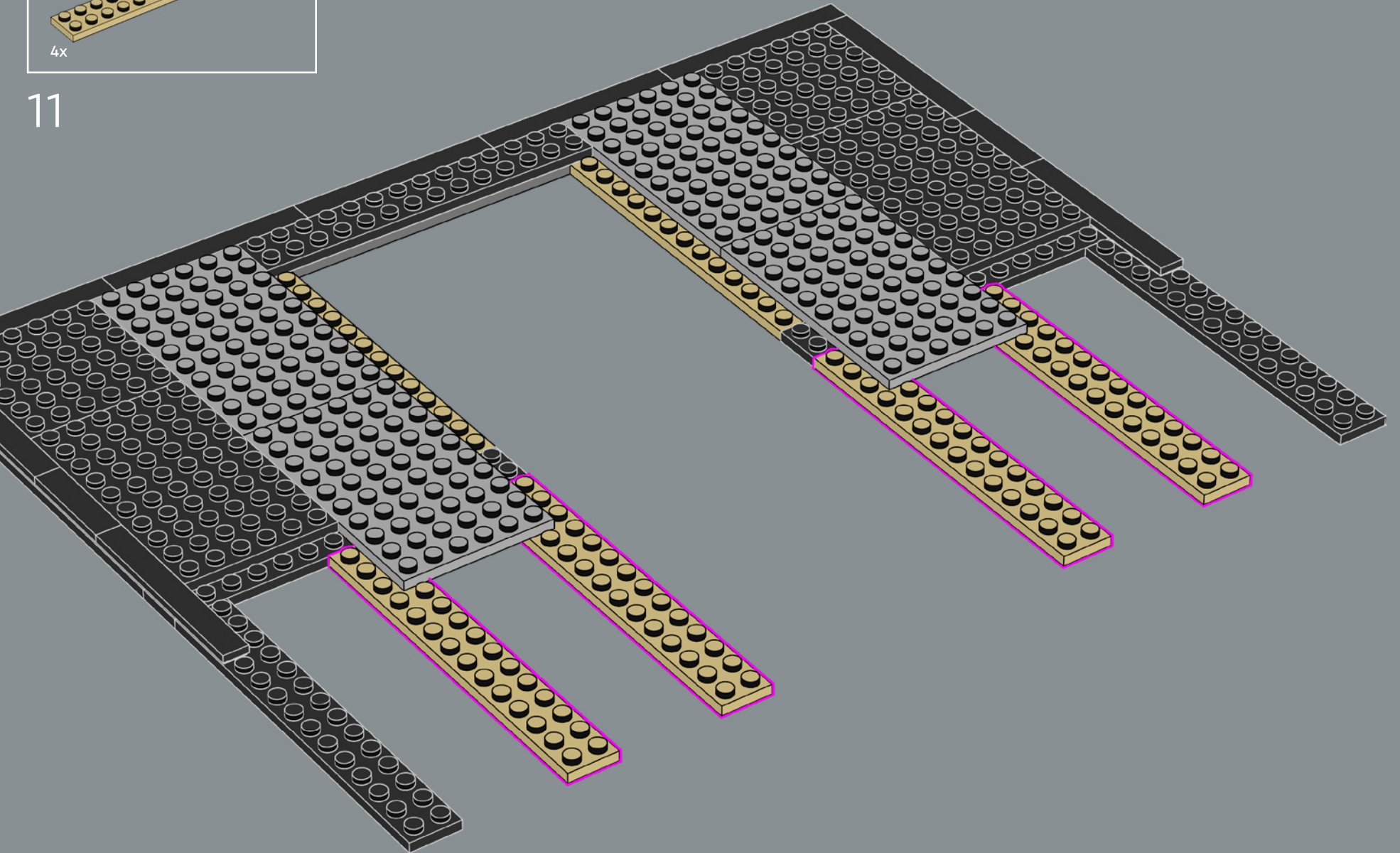

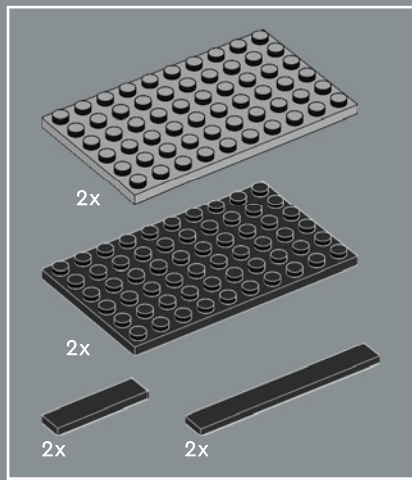

12

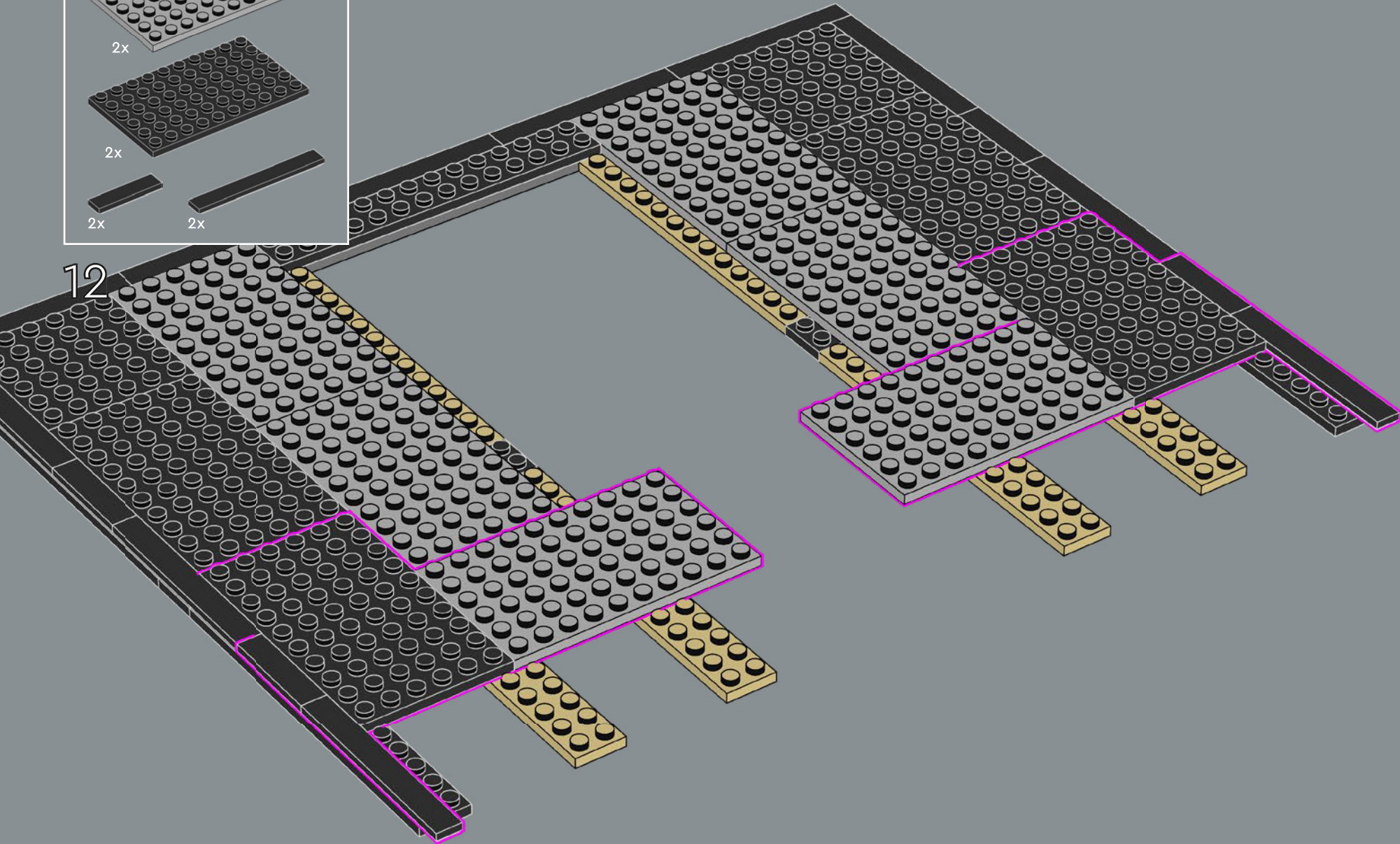

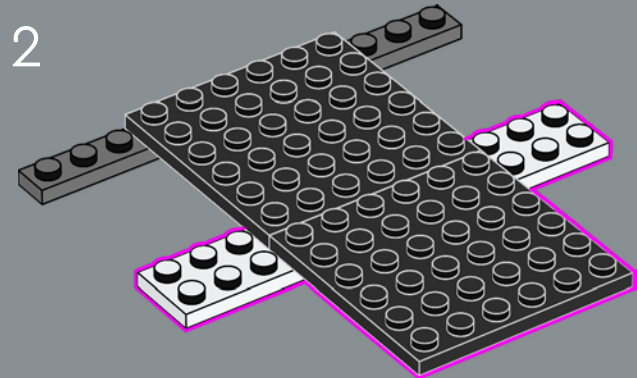
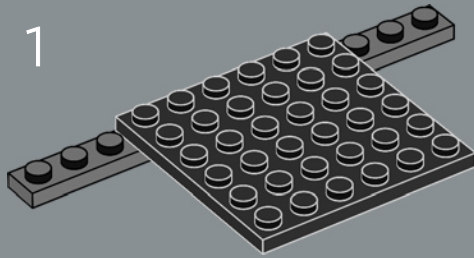
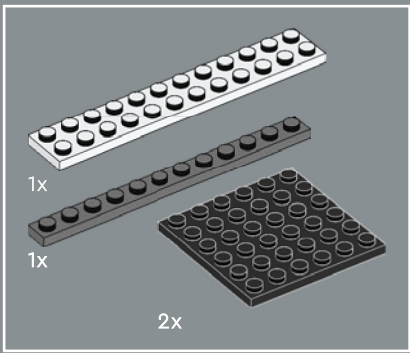

13

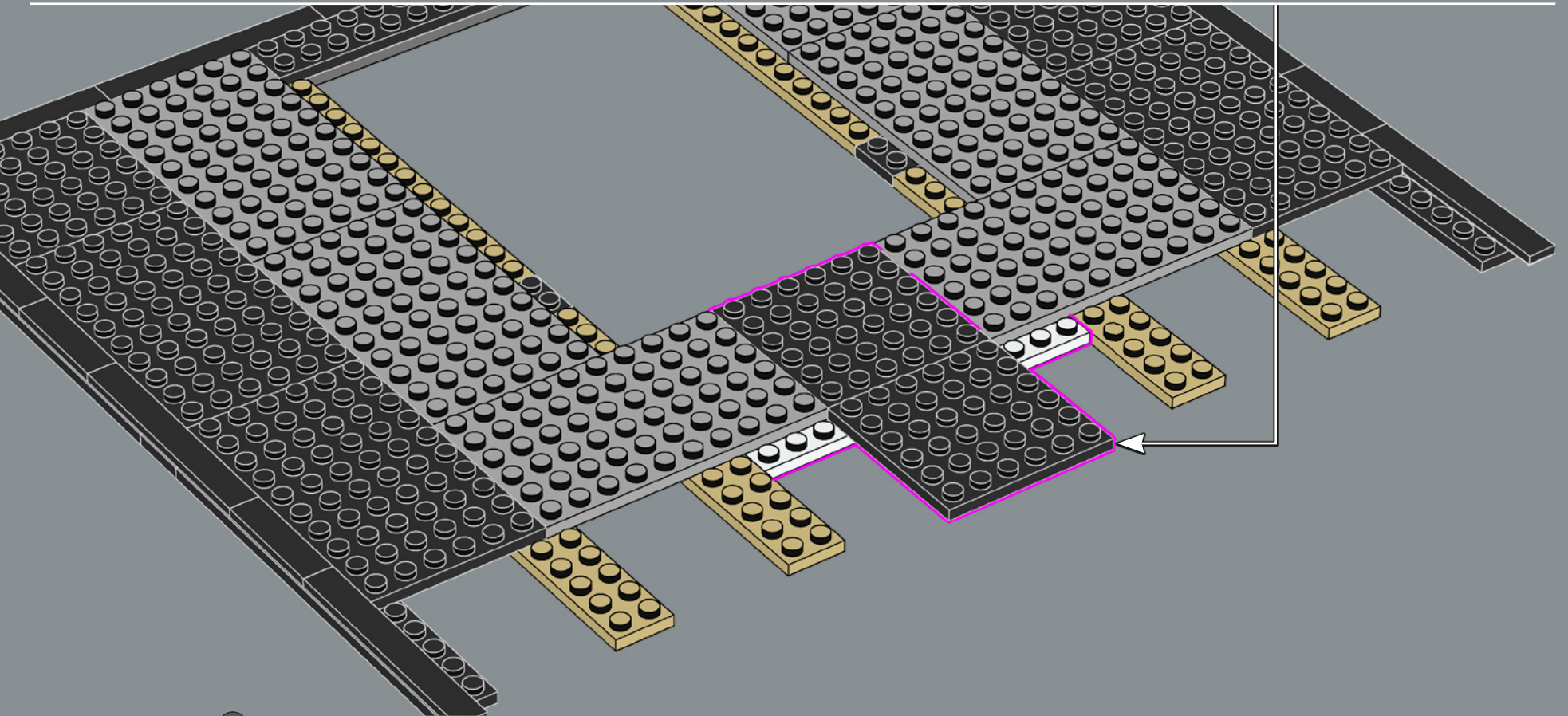

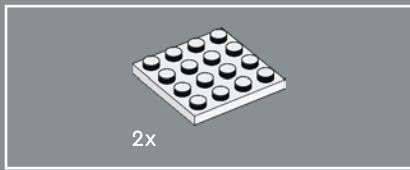

14

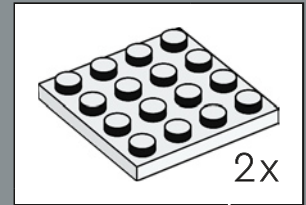
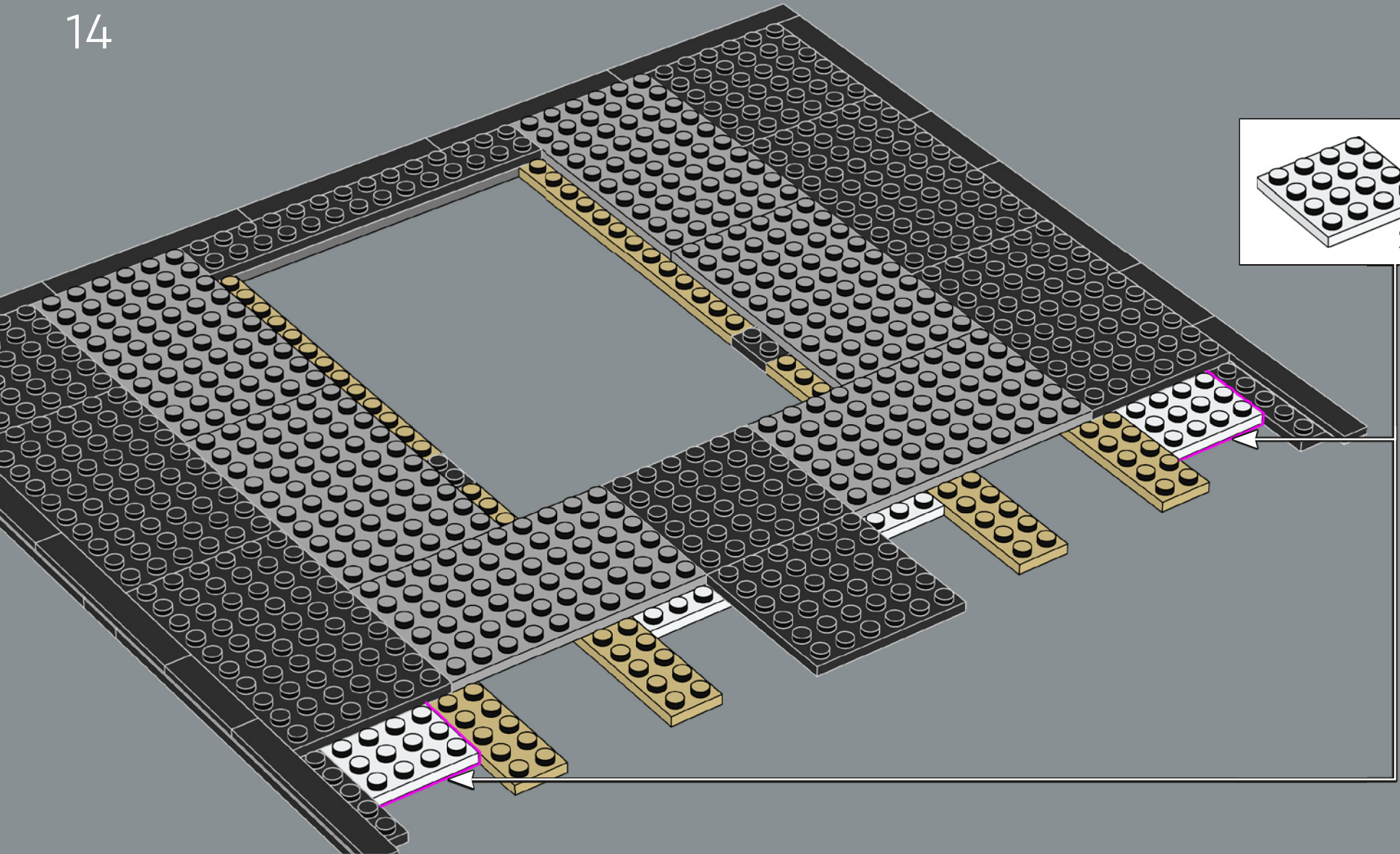

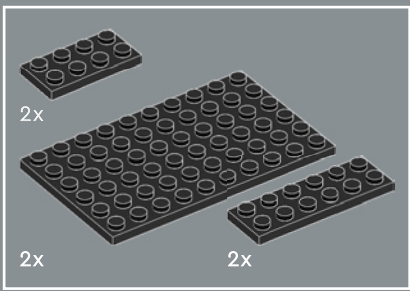

15

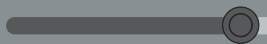
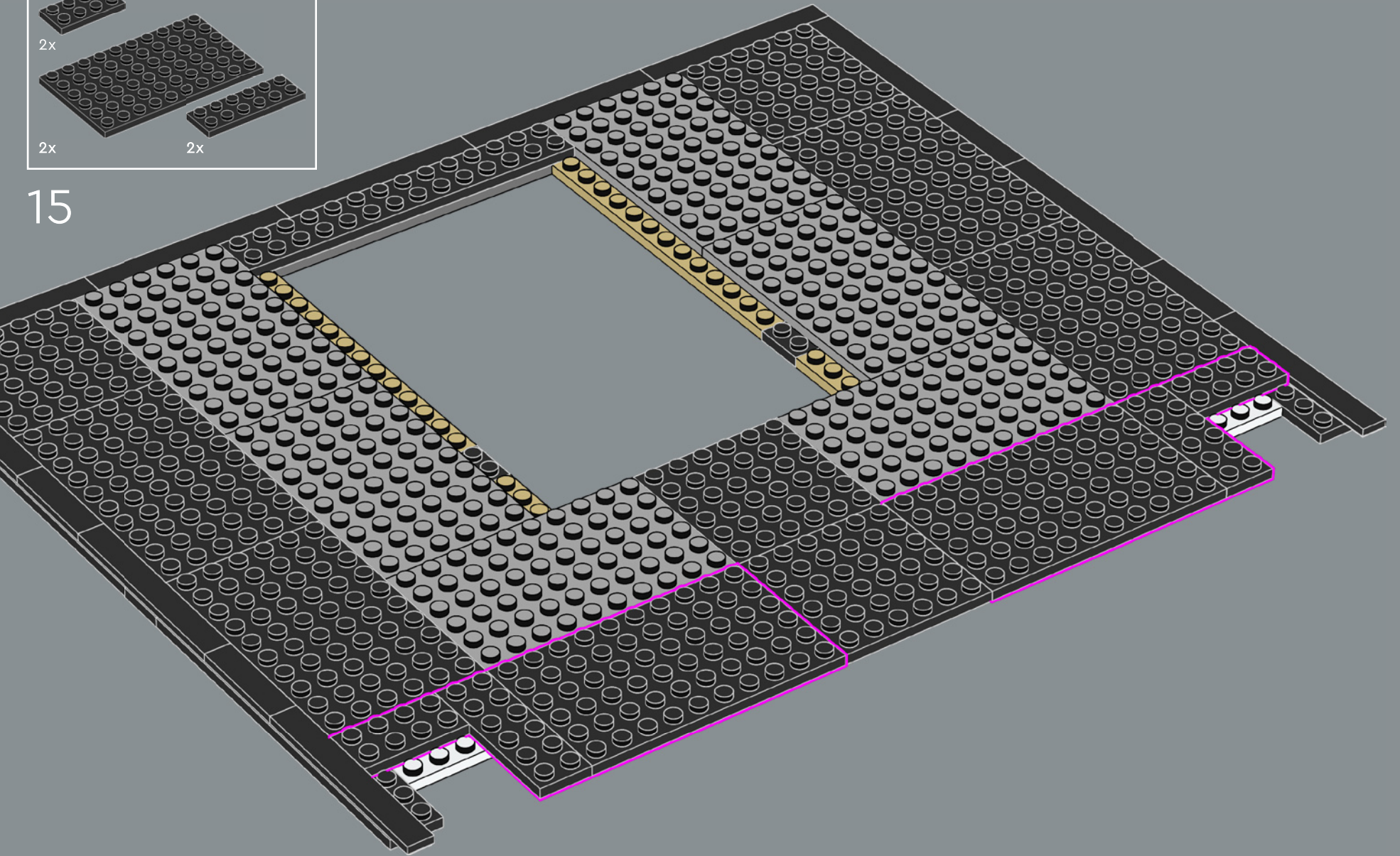

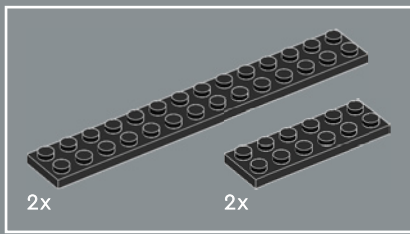

16

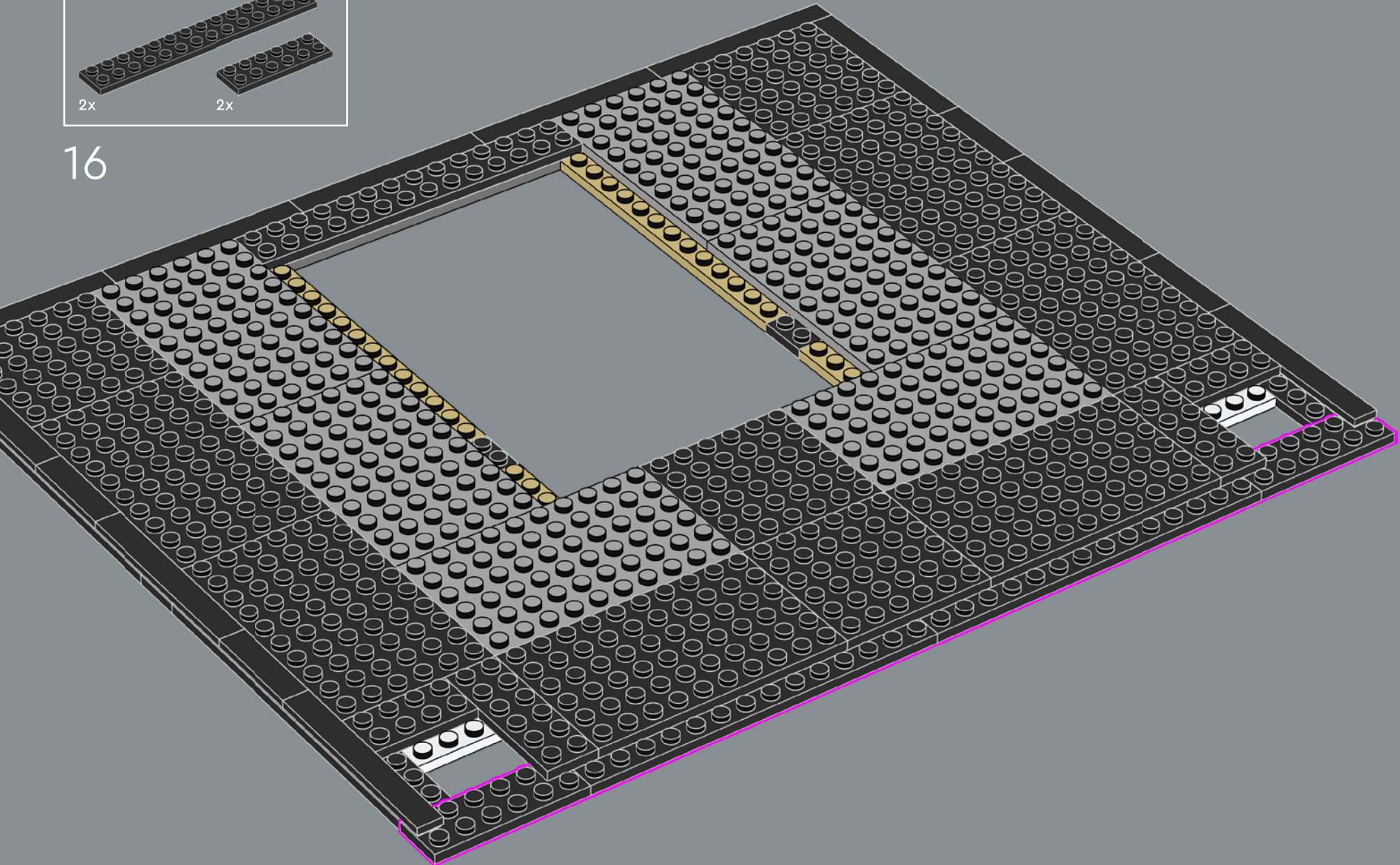

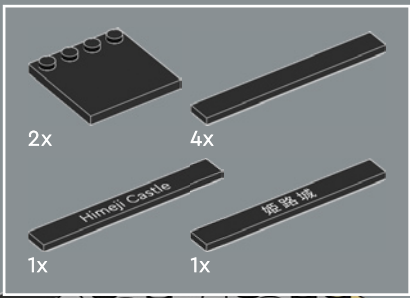

17

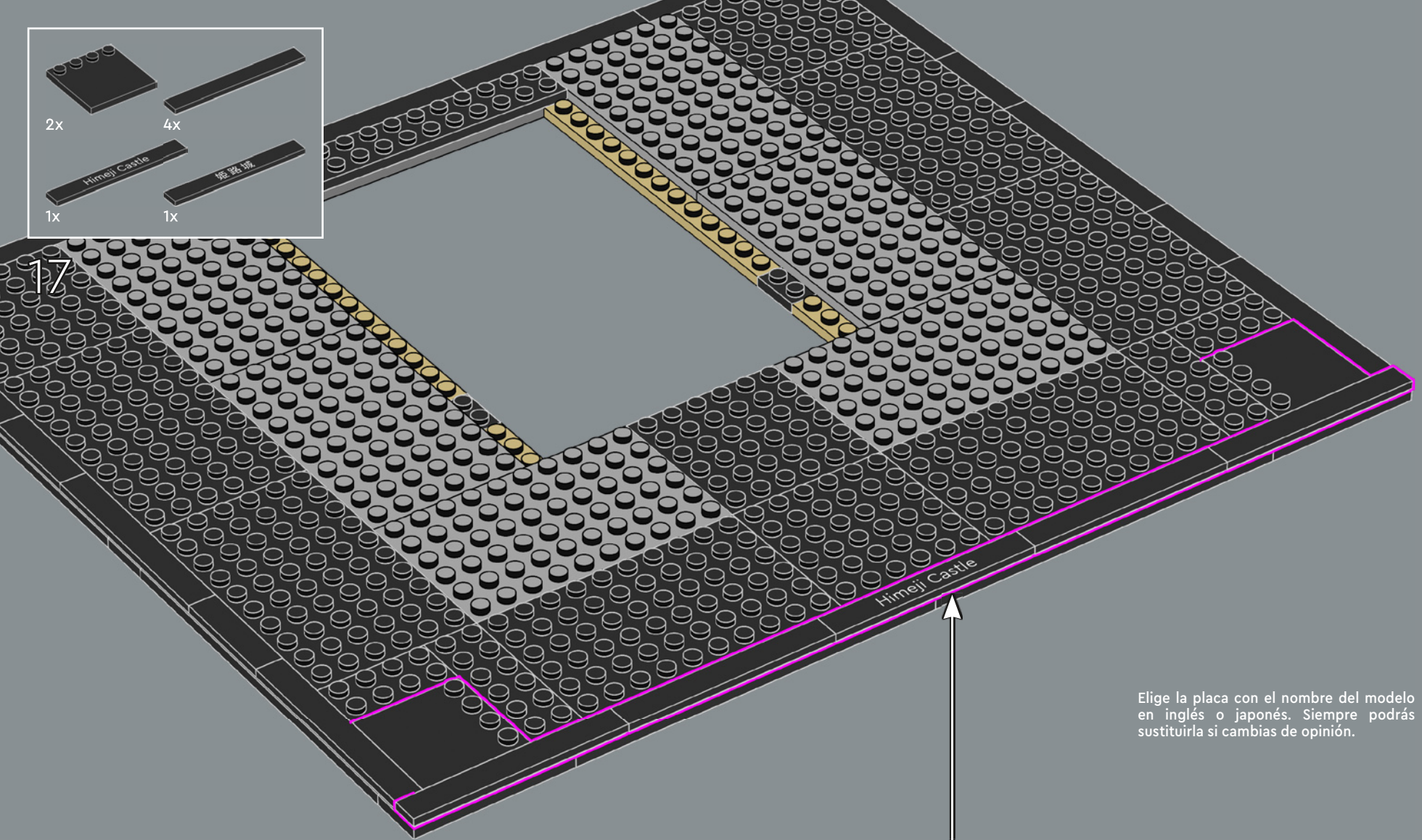

Elige la placa con el nombre del modelo en inglés o japonés. Siempre podrás sustituirla si cambias de opinión.

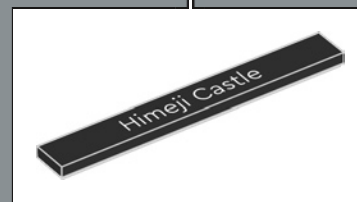

En 1993, el Castillo de Himeji fue declarado Patrimonio de la Humanidad por la UNESCO, reconociéndose así la obra maestra y su carácter representativo como culmen de la arquitectura japonesa de castillos de madera.

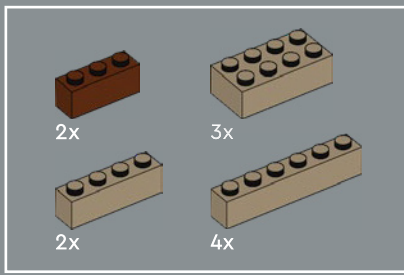

18

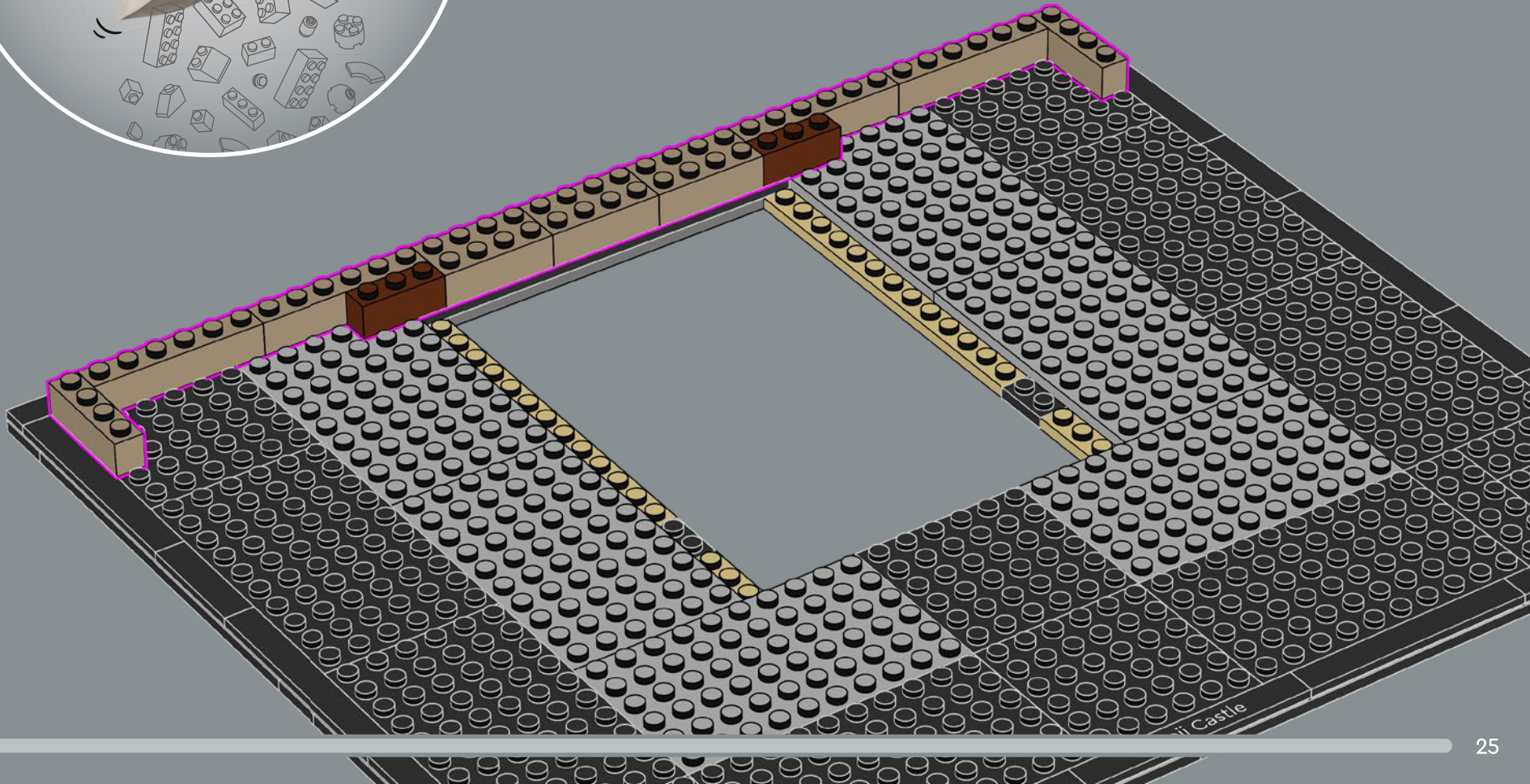

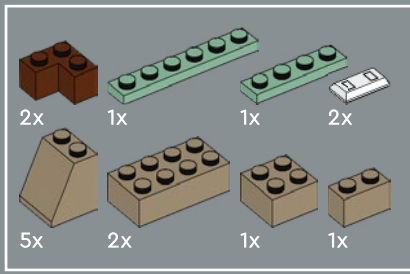

20

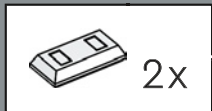
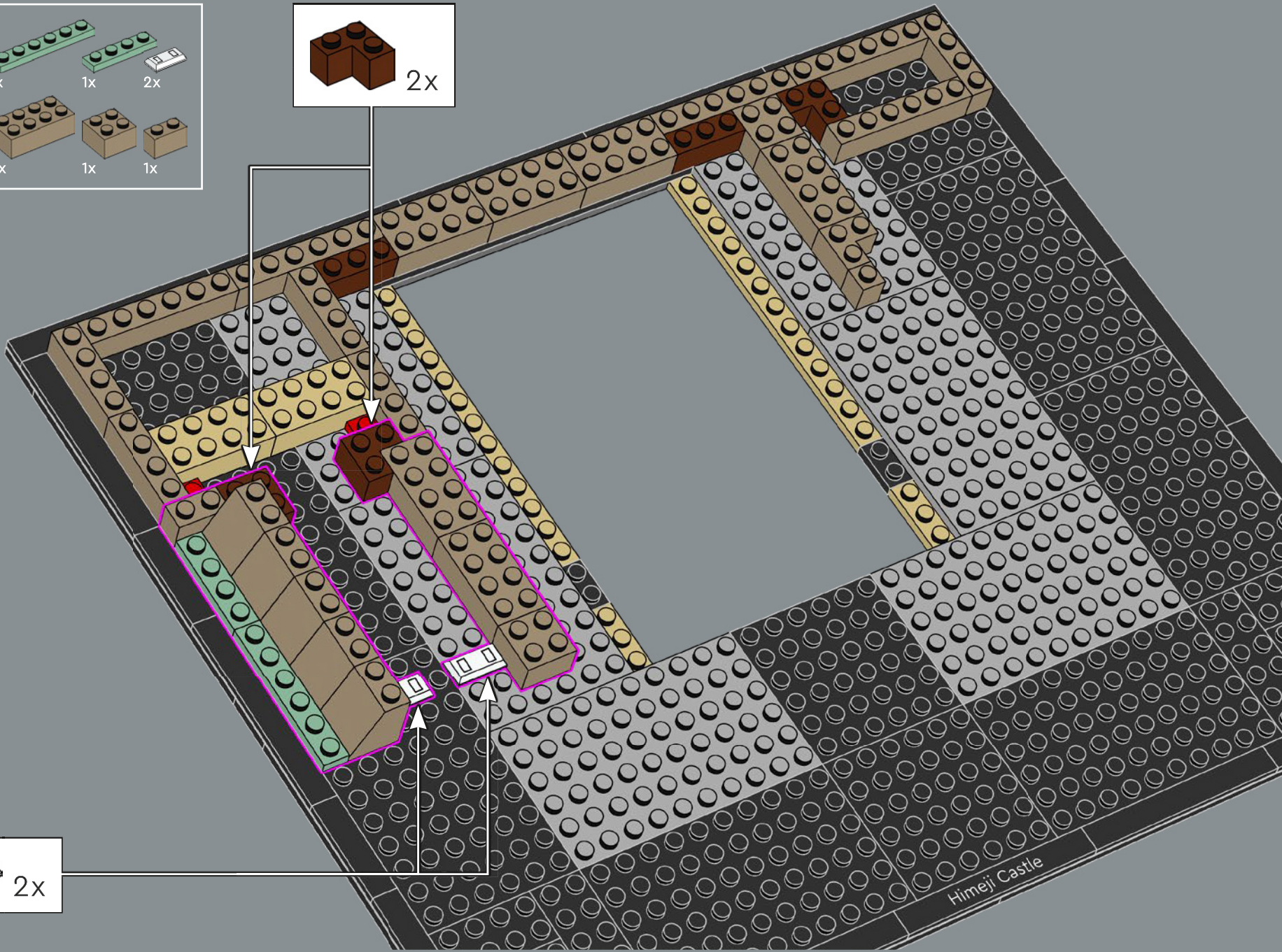

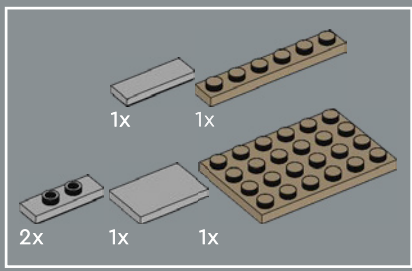



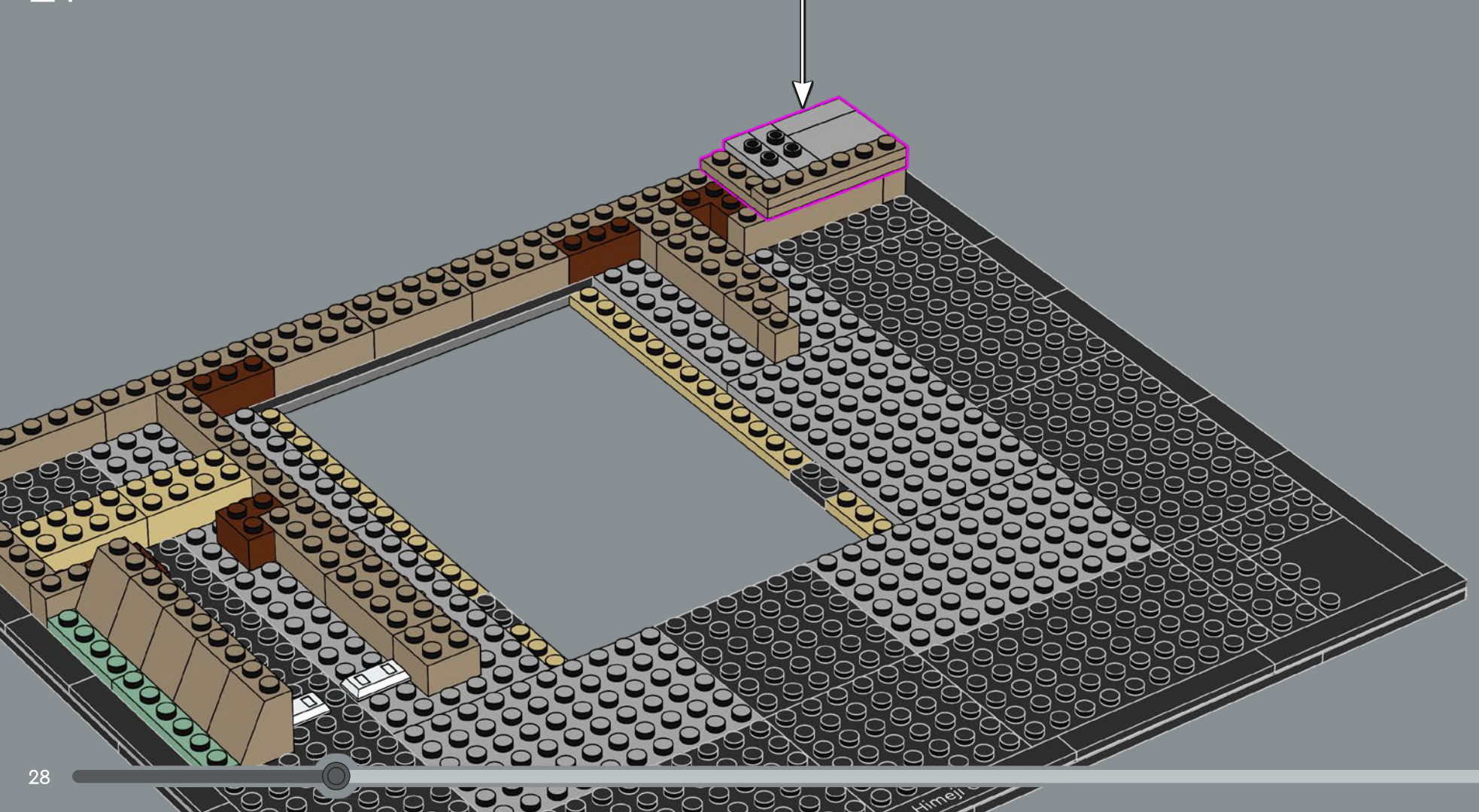
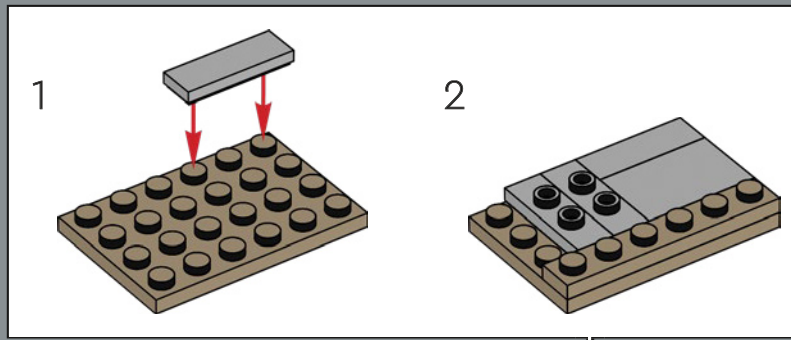

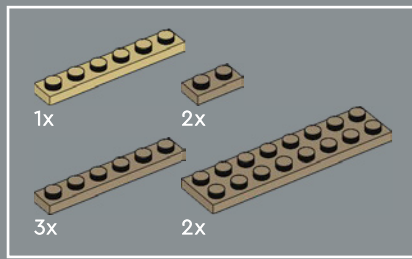

21

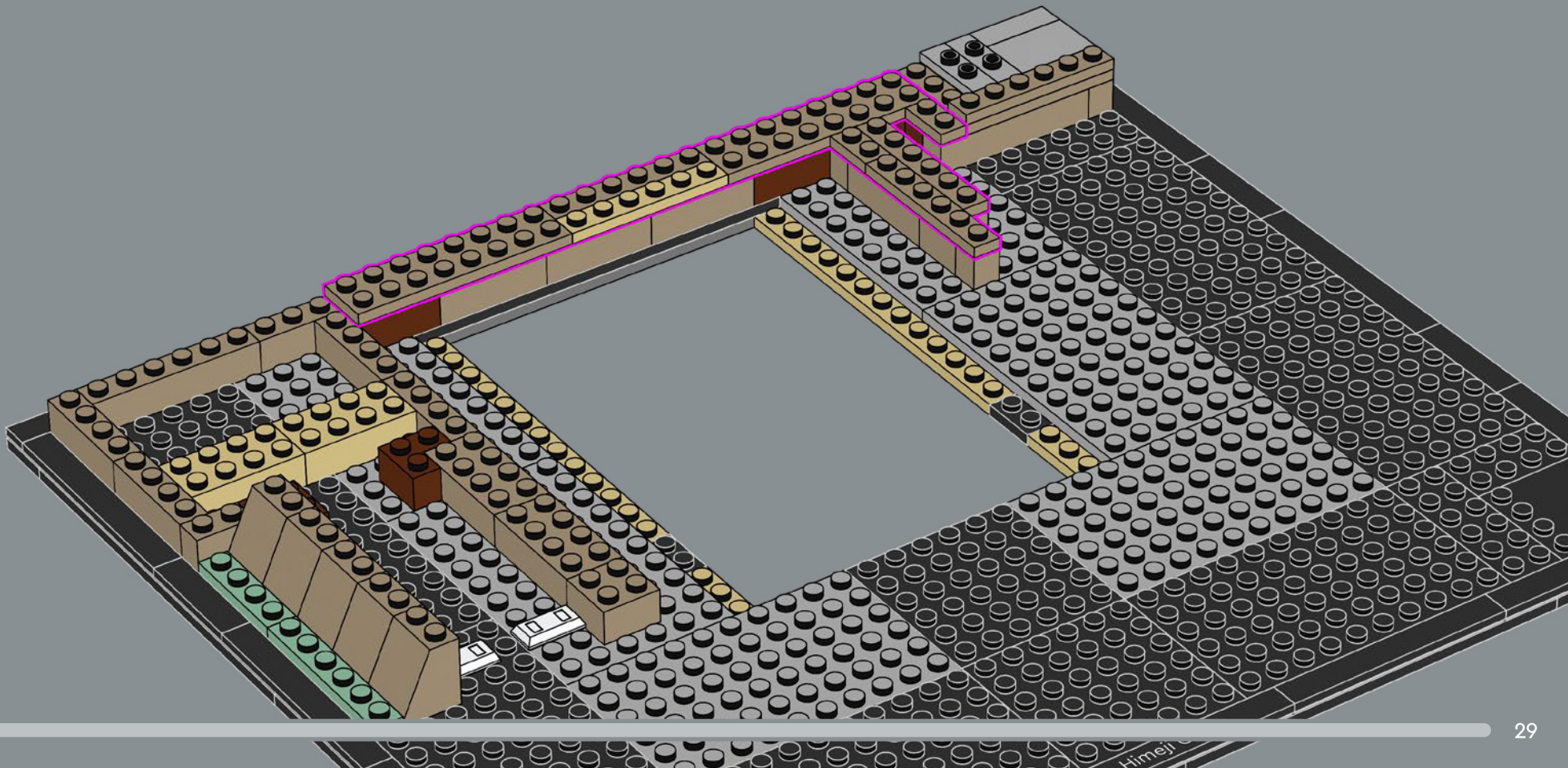



22



- 1x 
- 1x 
- 2x 
- 2x 
- 1x 

23

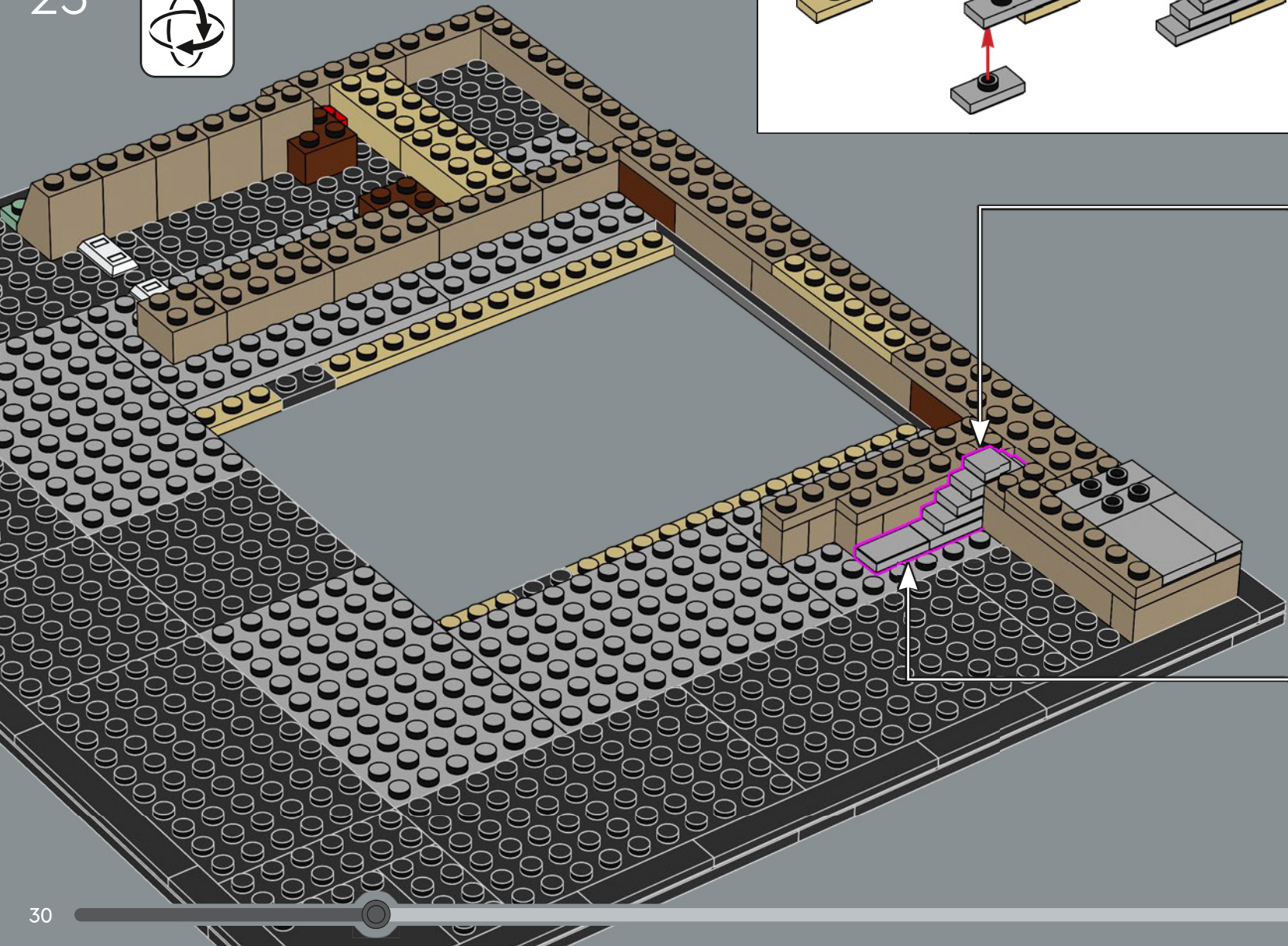
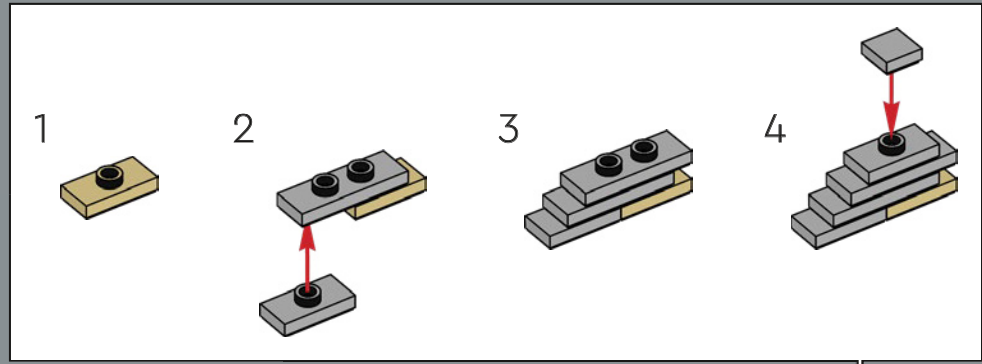

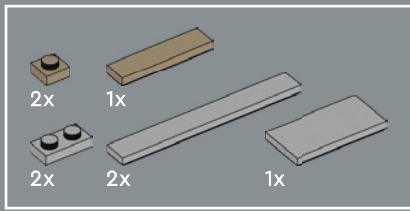

24

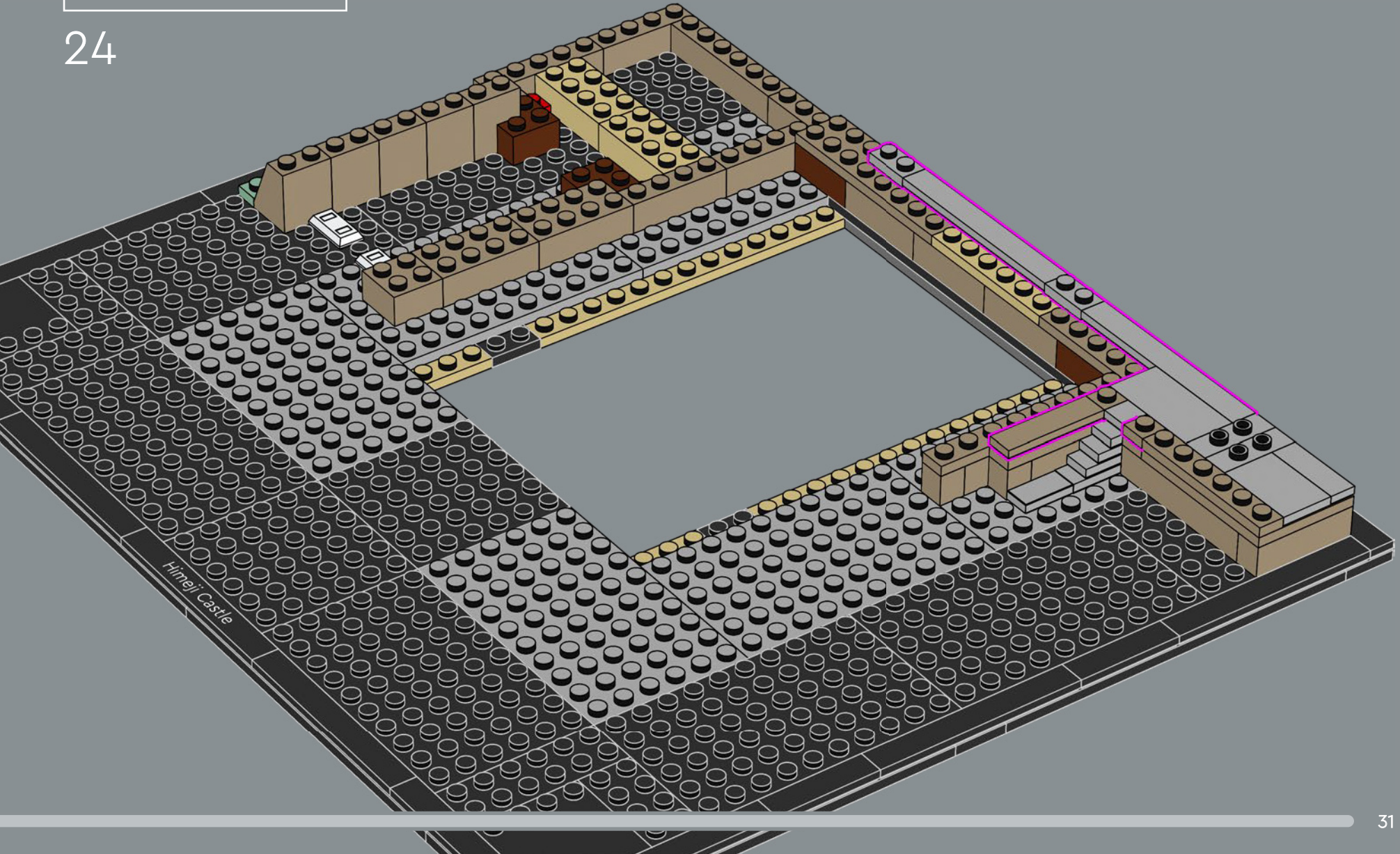

1x  4x  1x 

25

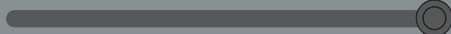
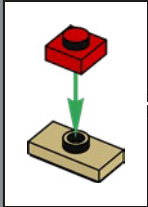
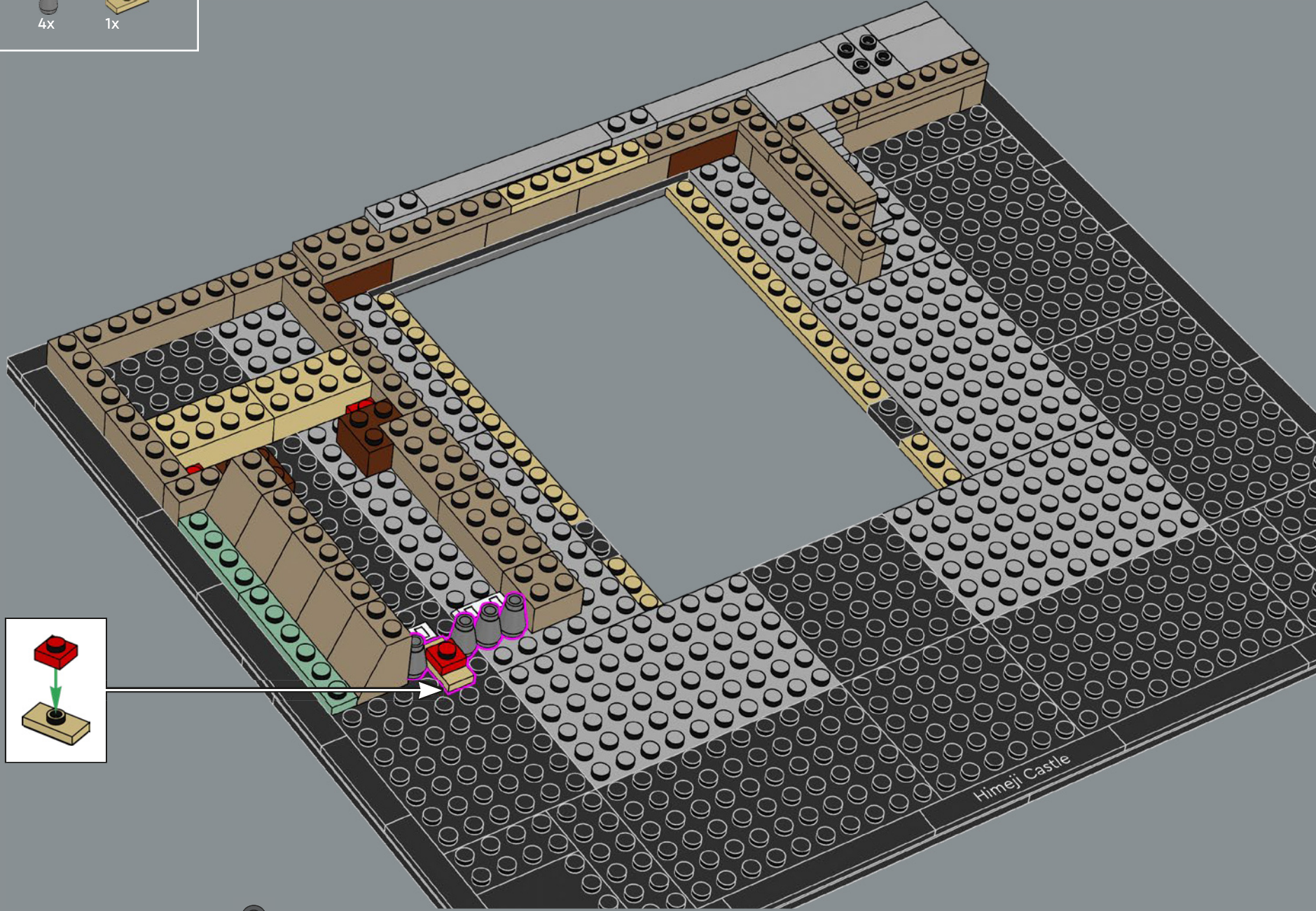

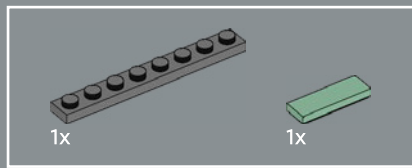

26

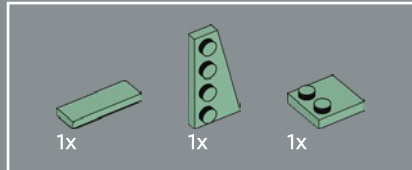
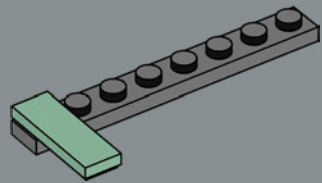

27

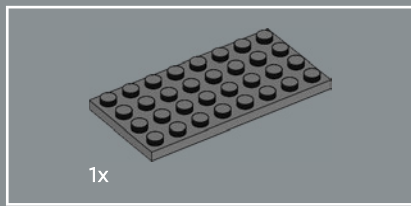
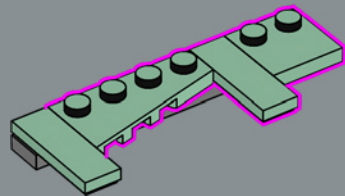

28

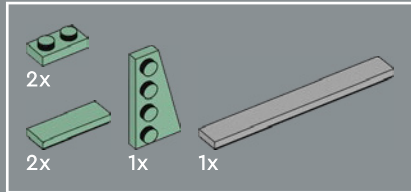
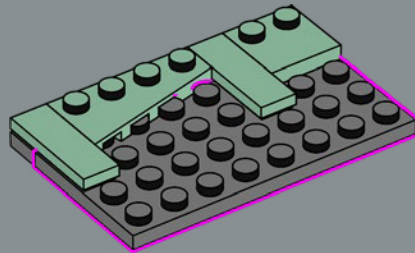

29

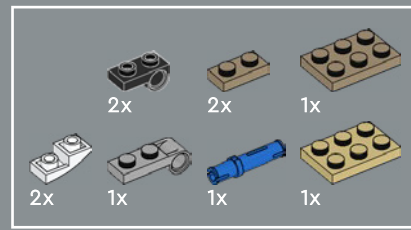
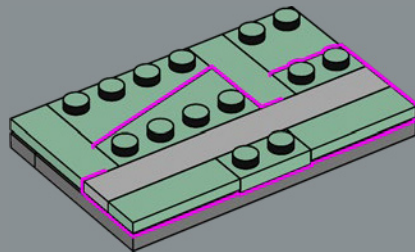

30

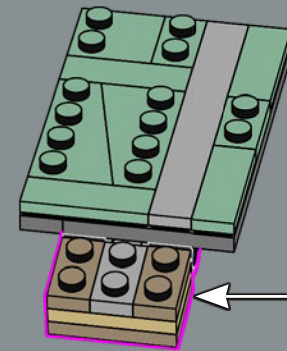
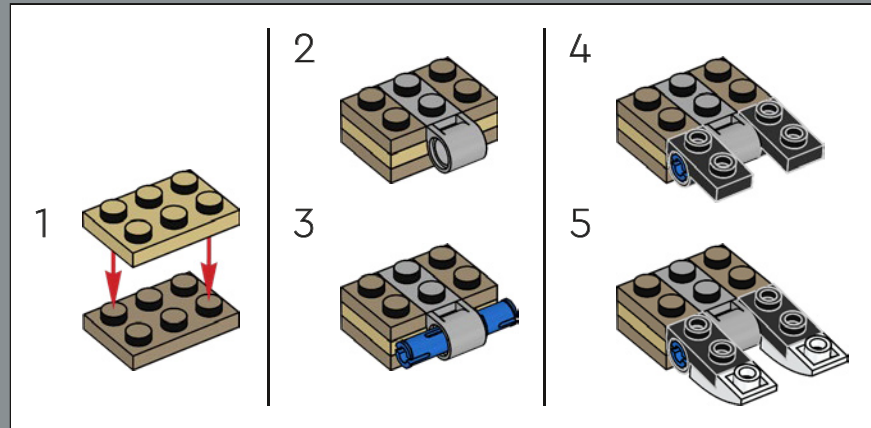

31

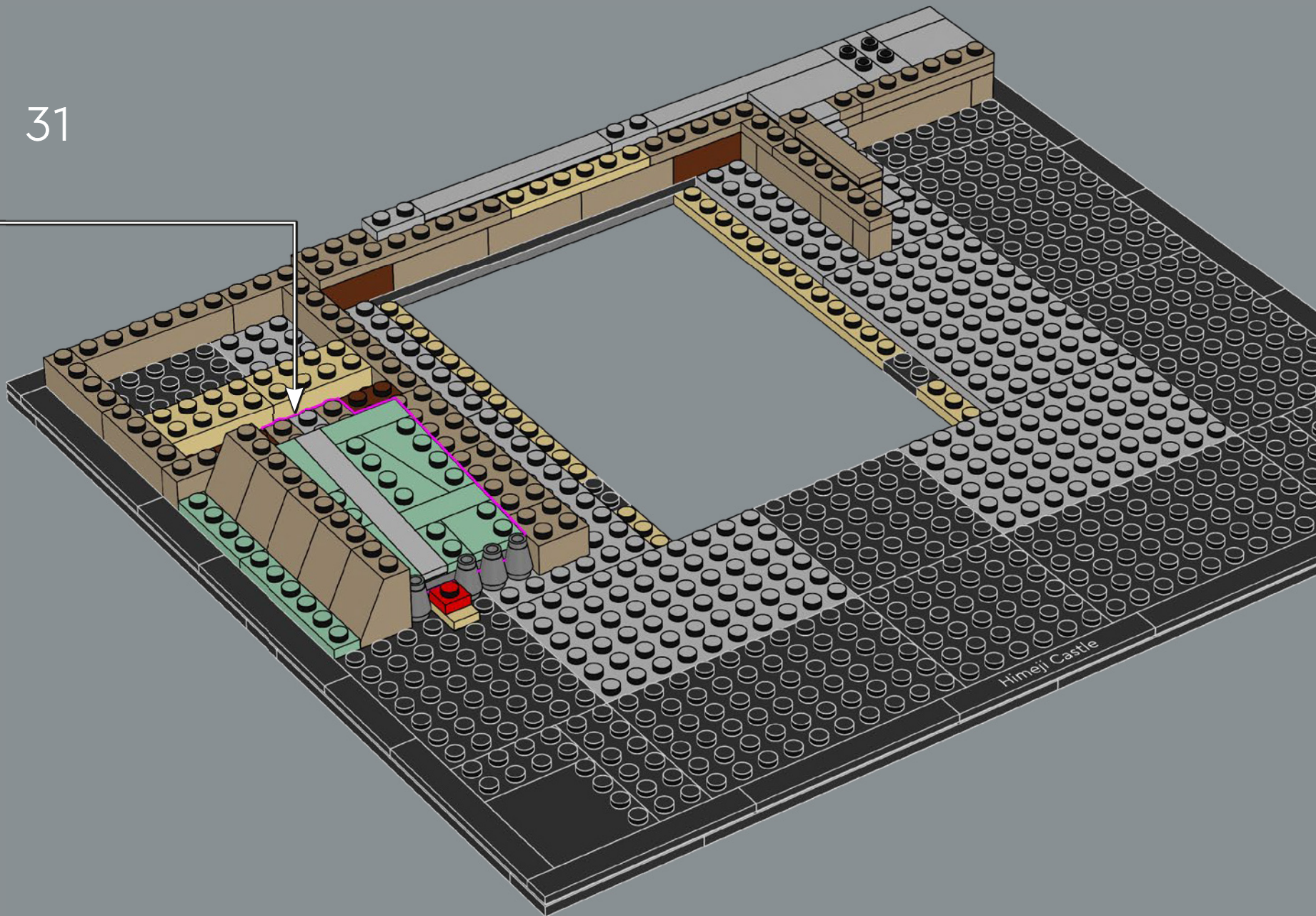

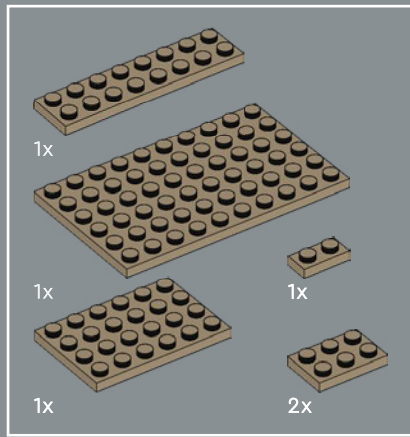

32

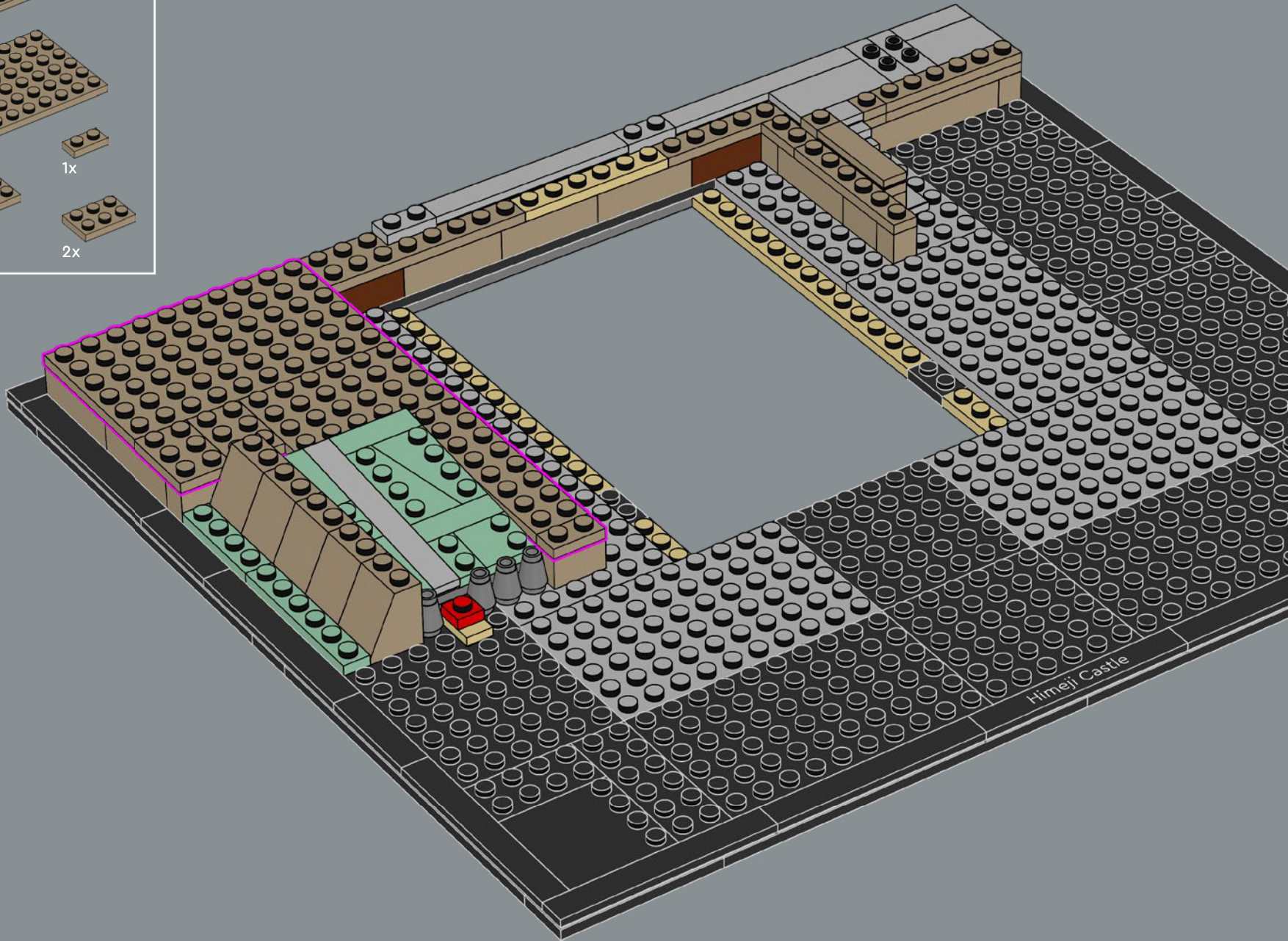

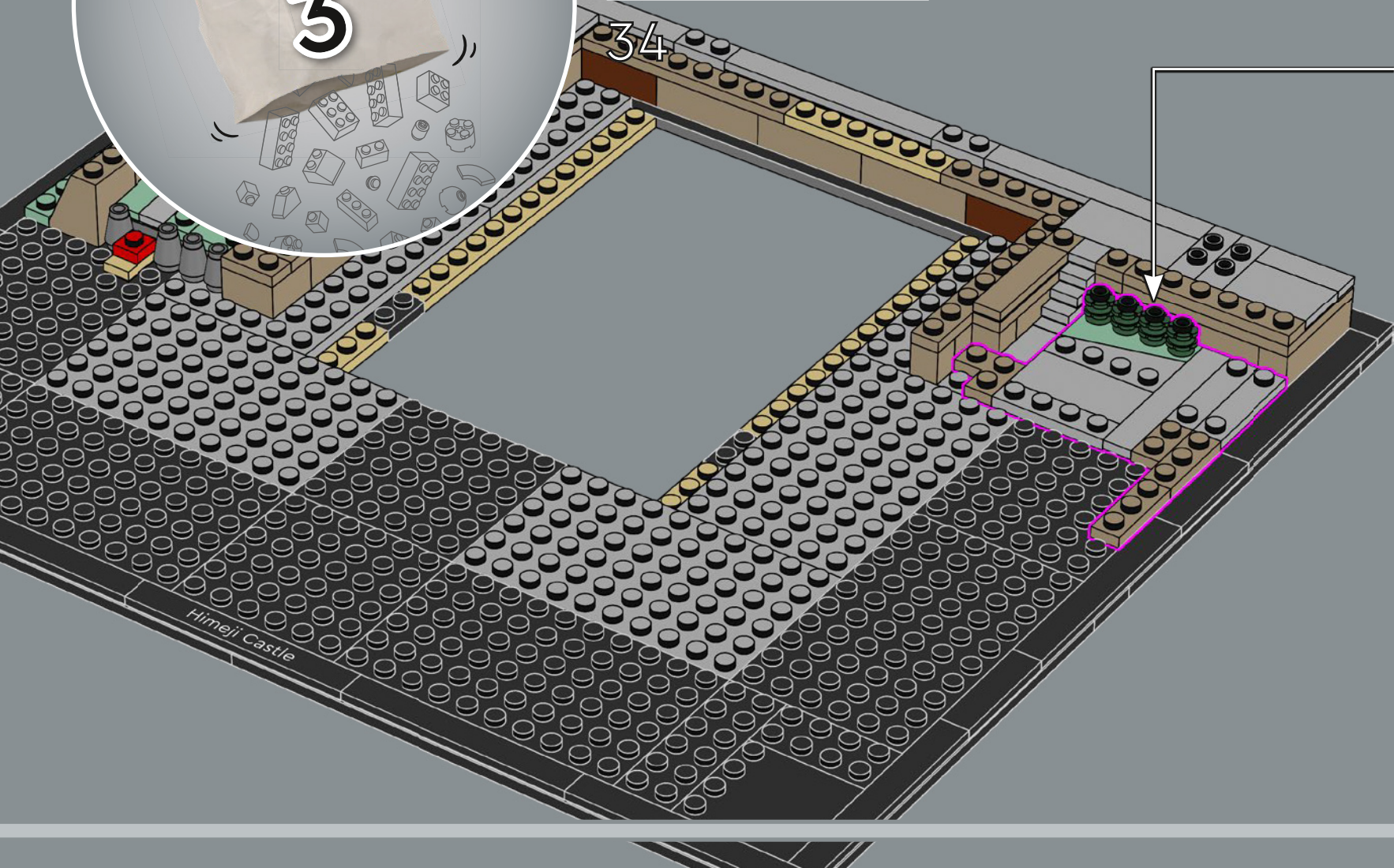
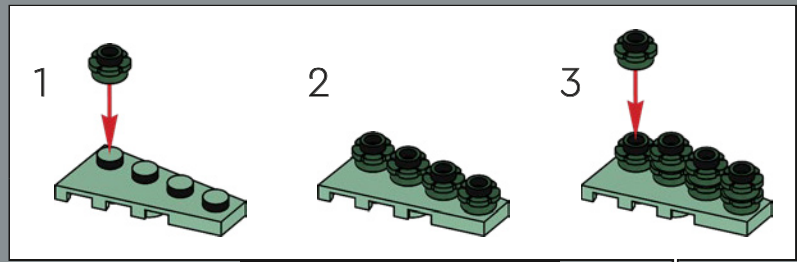
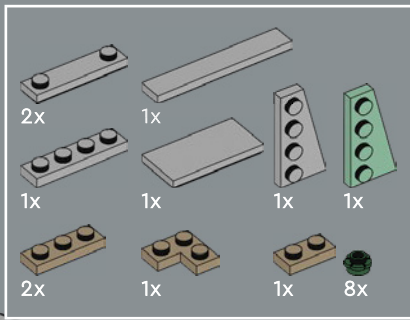

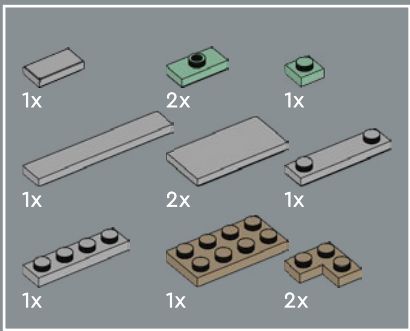

35

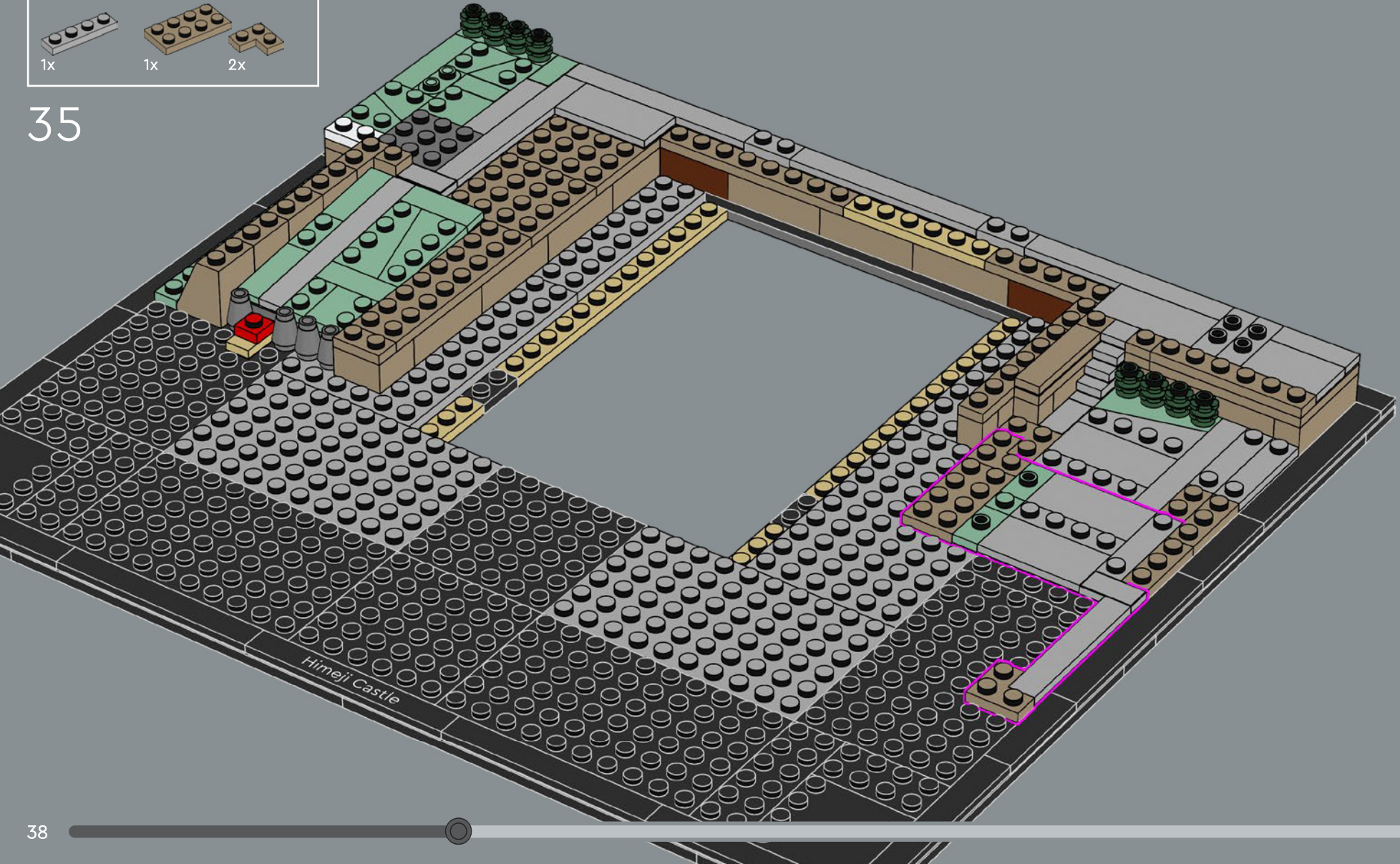

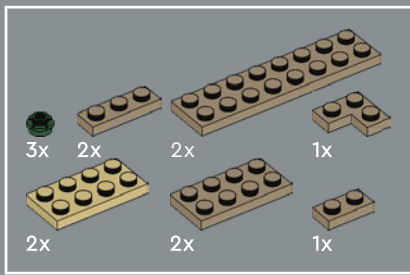

36

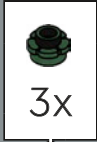
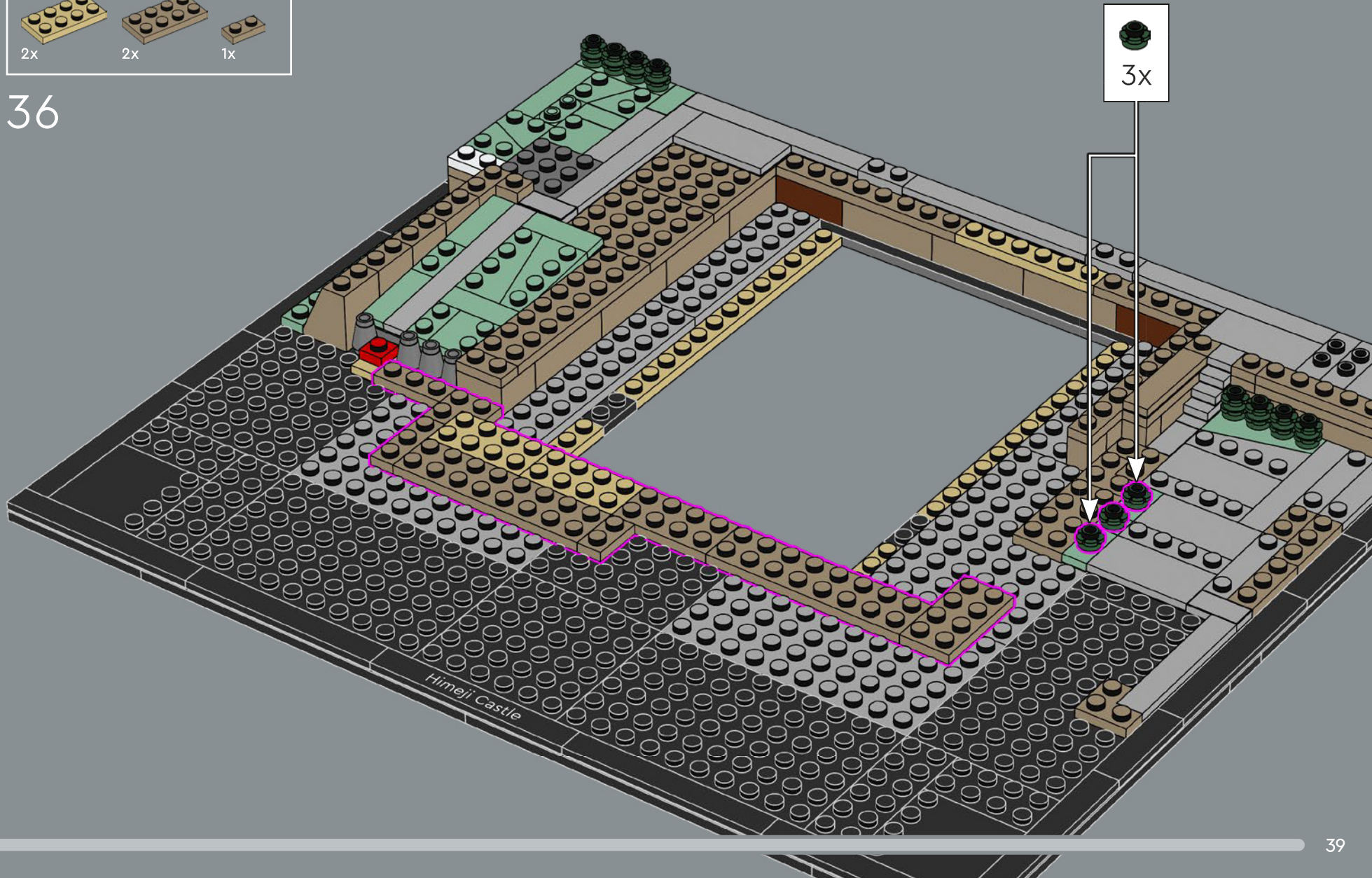

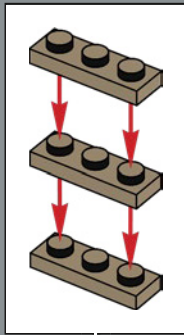
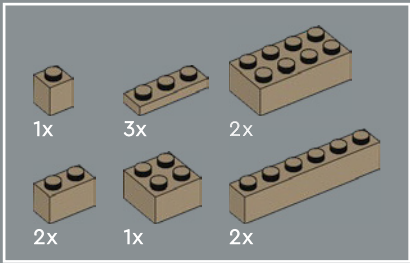

37

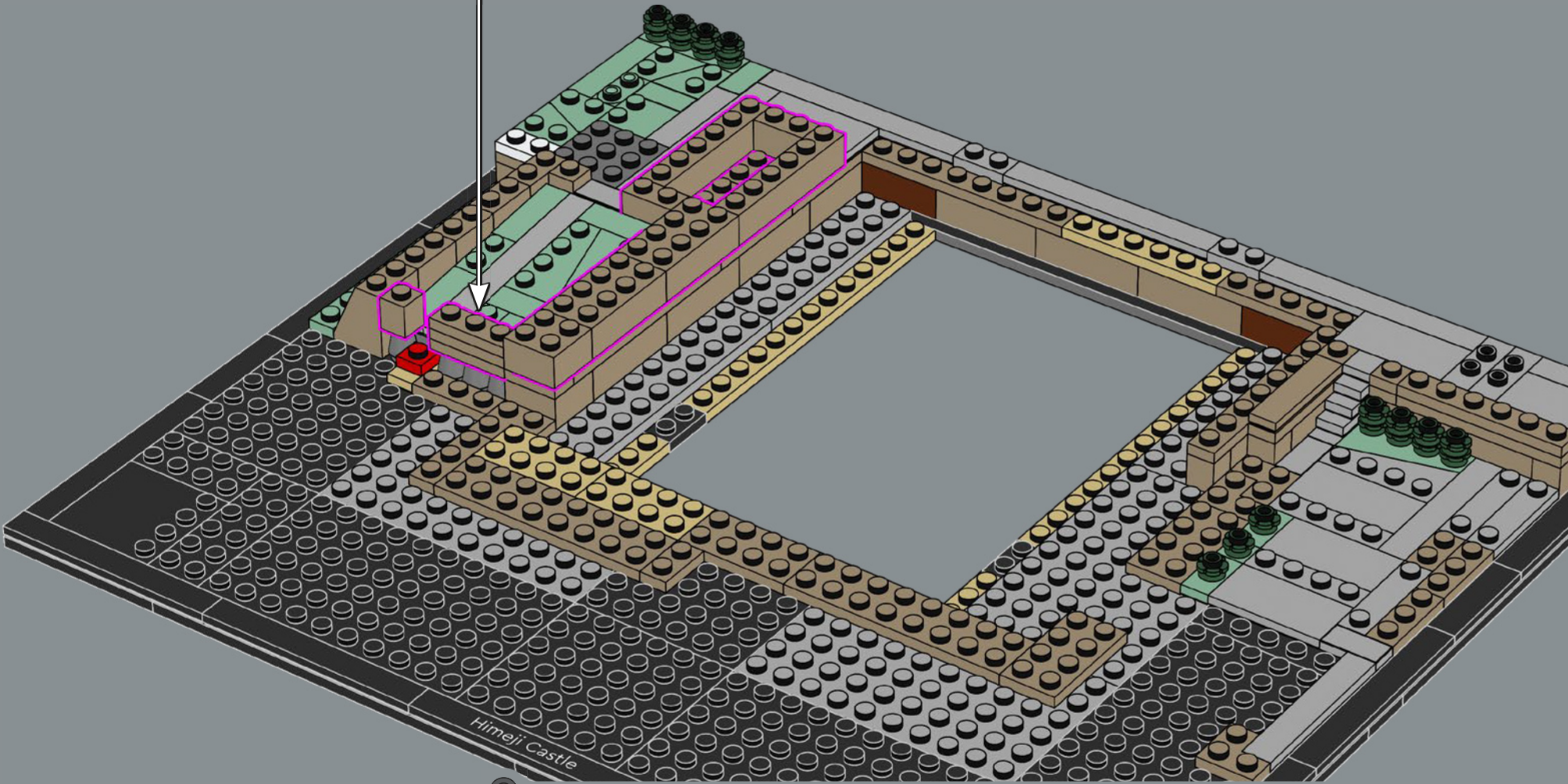

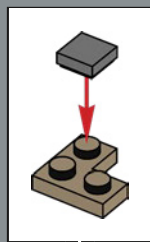
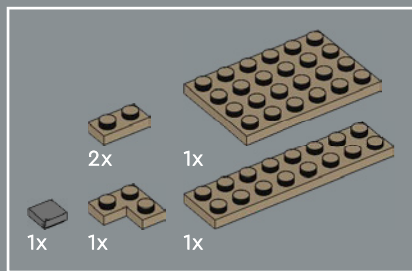

38

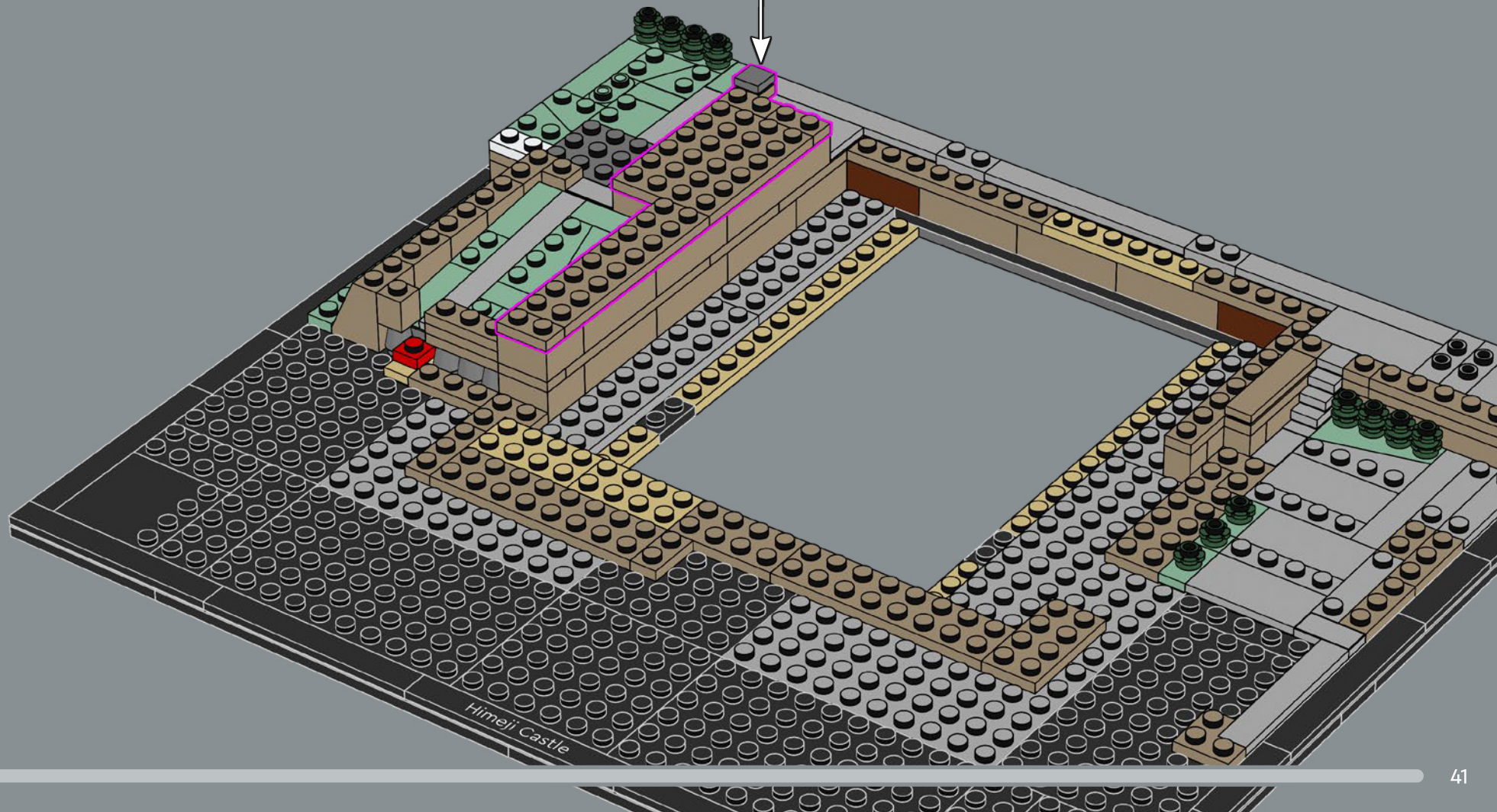

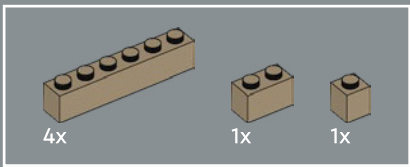

39

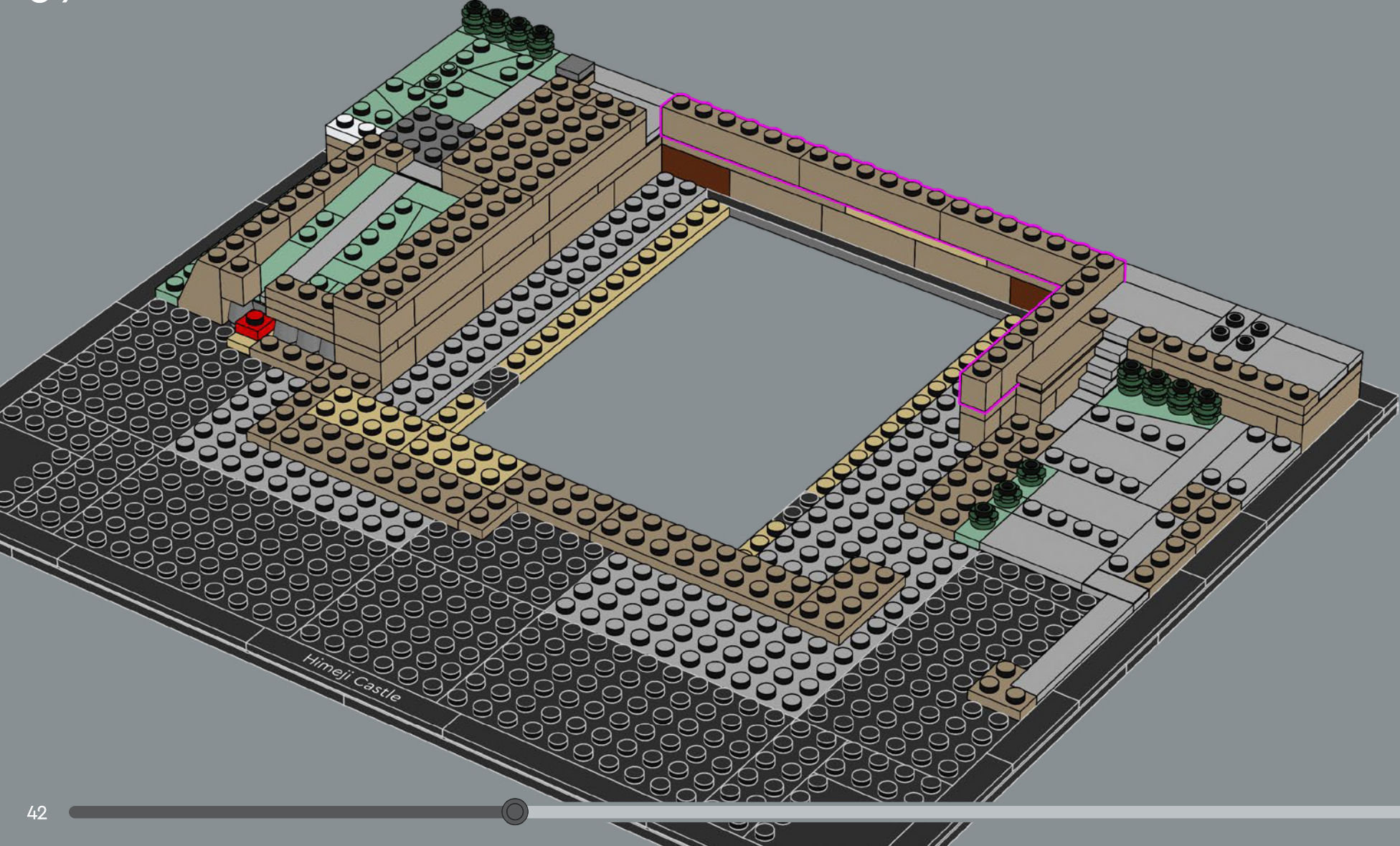

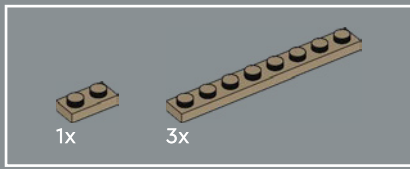

40

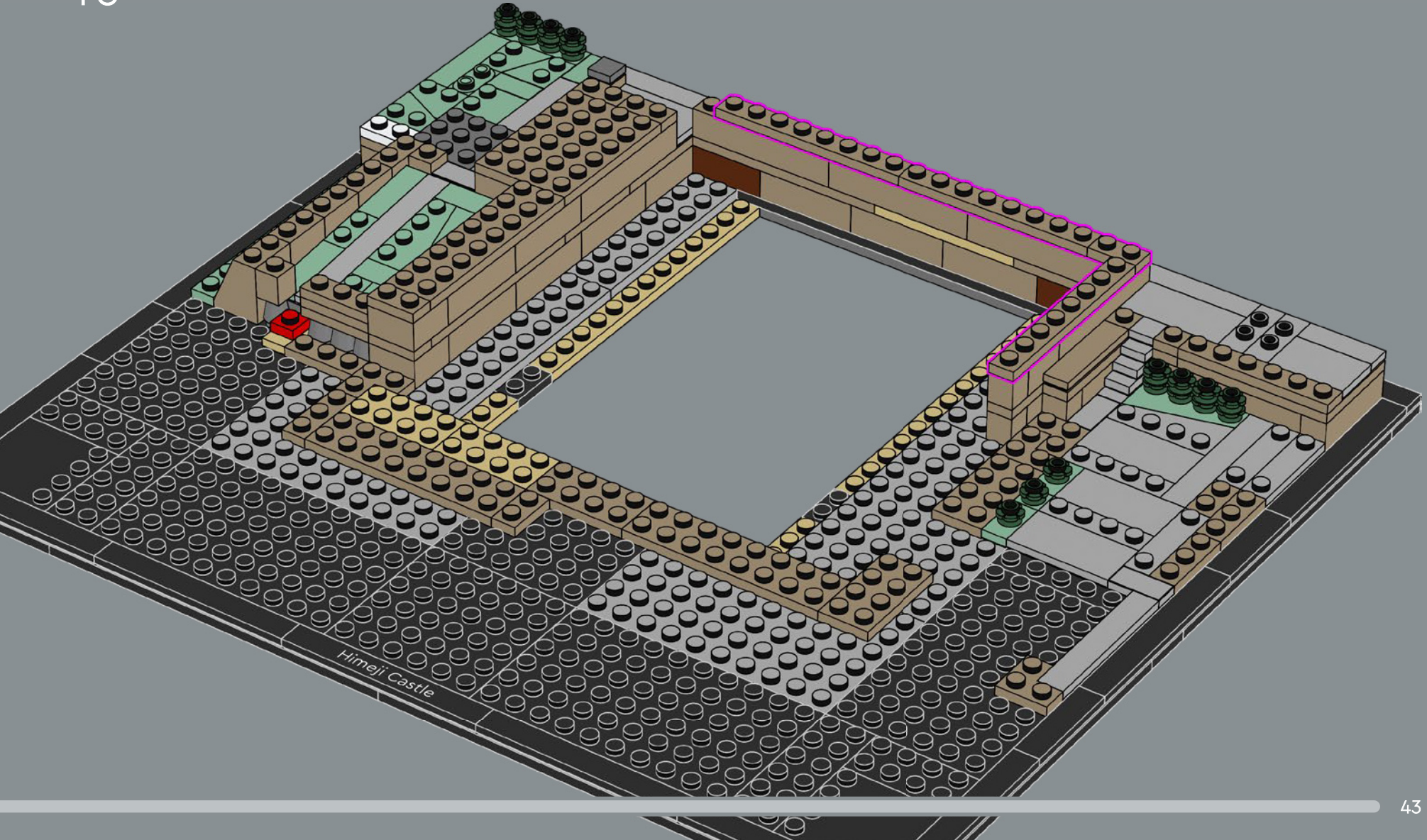

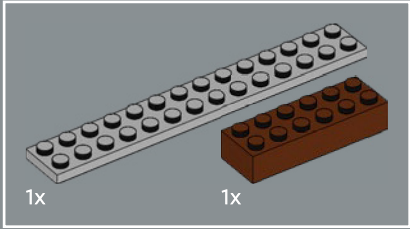
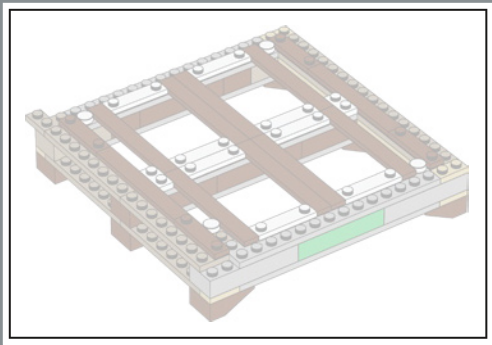

41

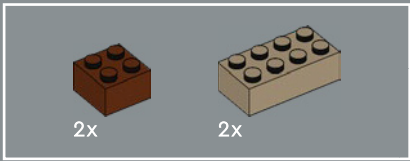
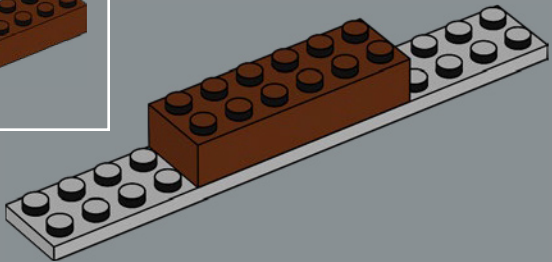

42

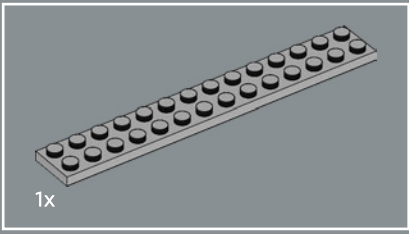
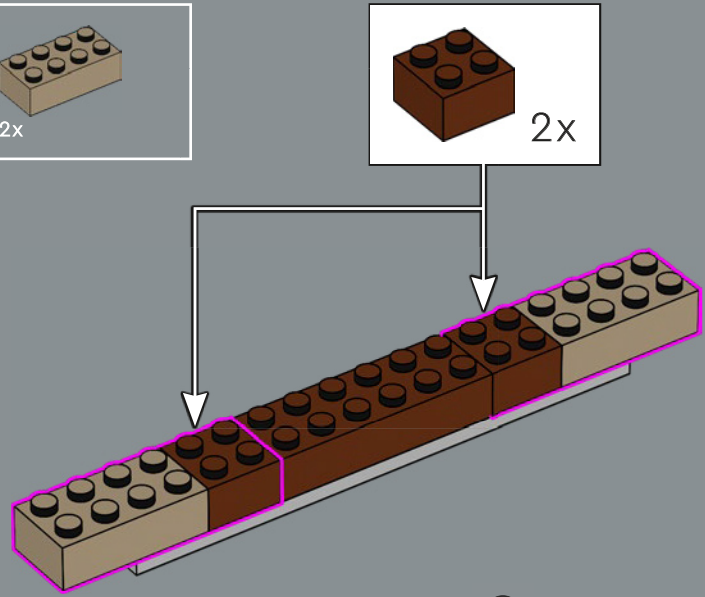

43

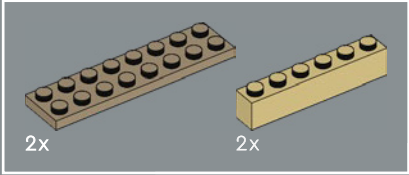
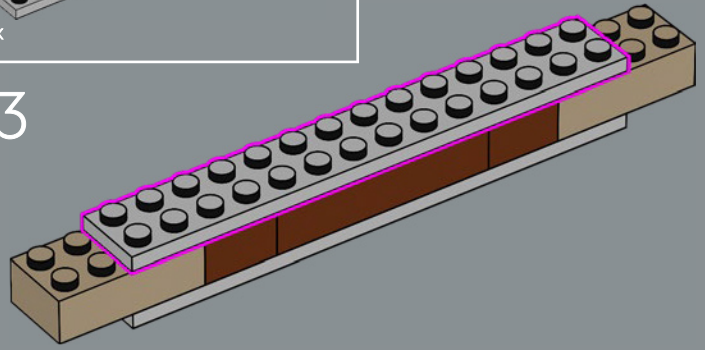

44

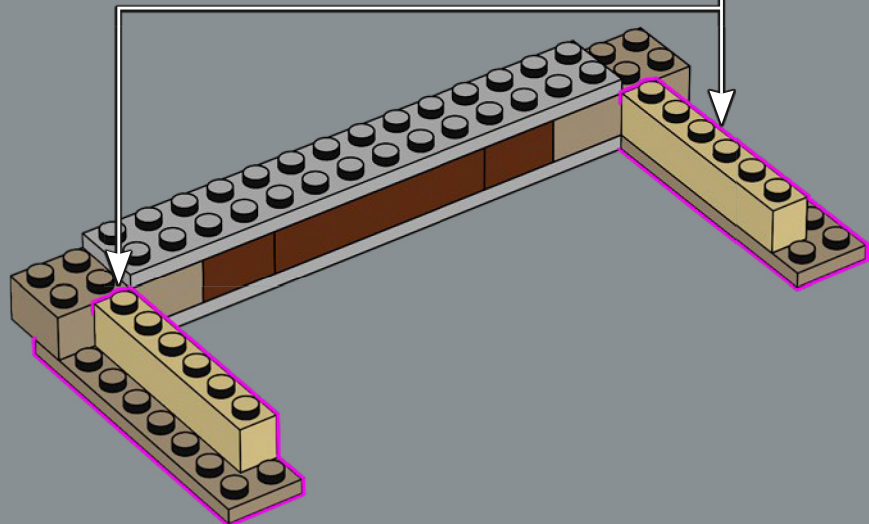
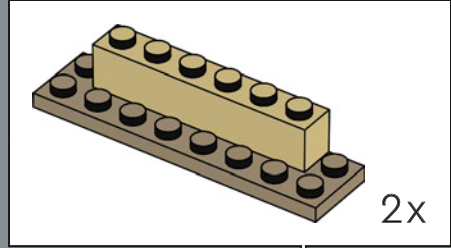

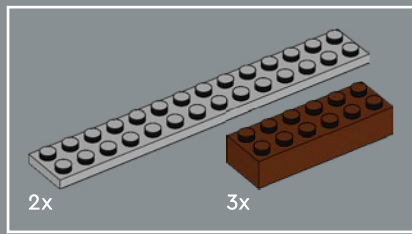

45

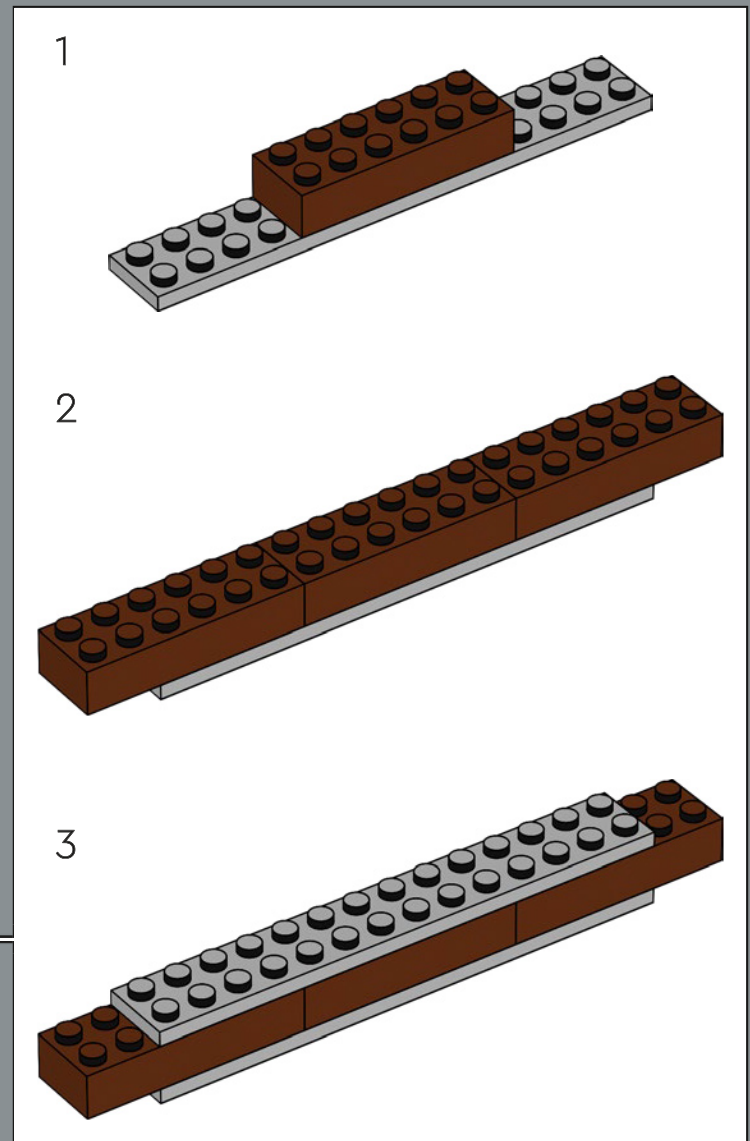
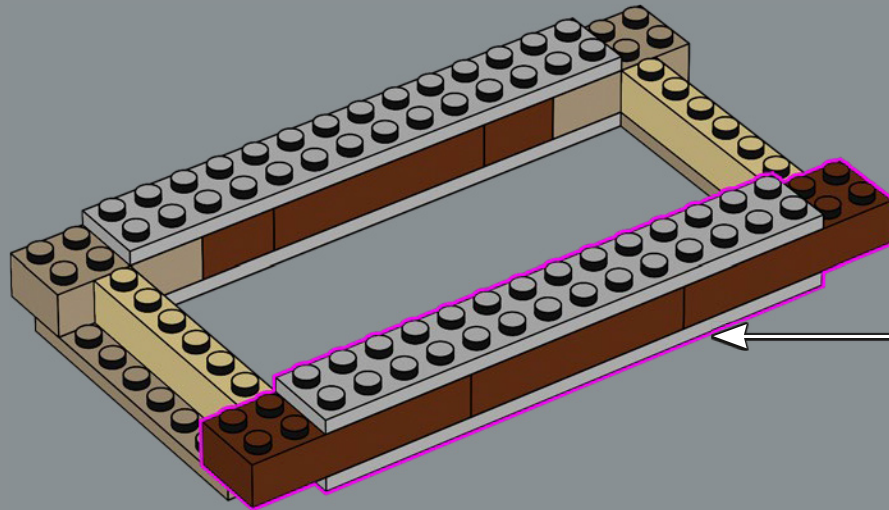

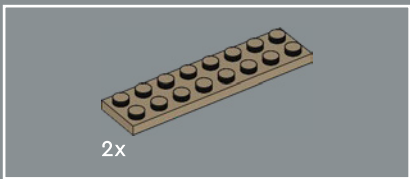

46

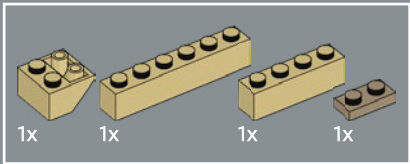
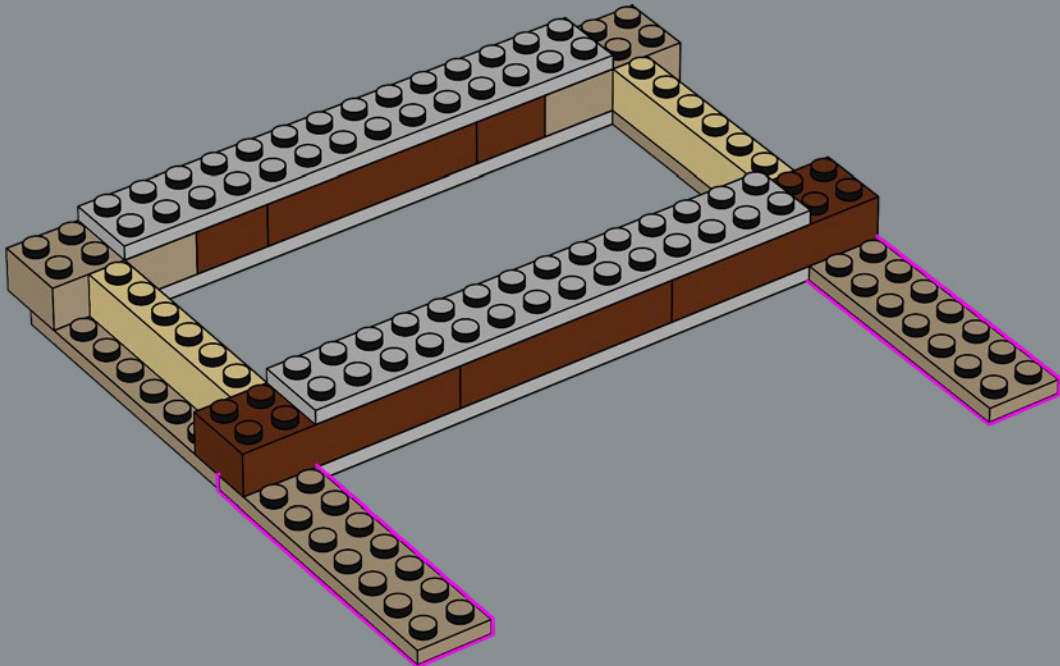

47

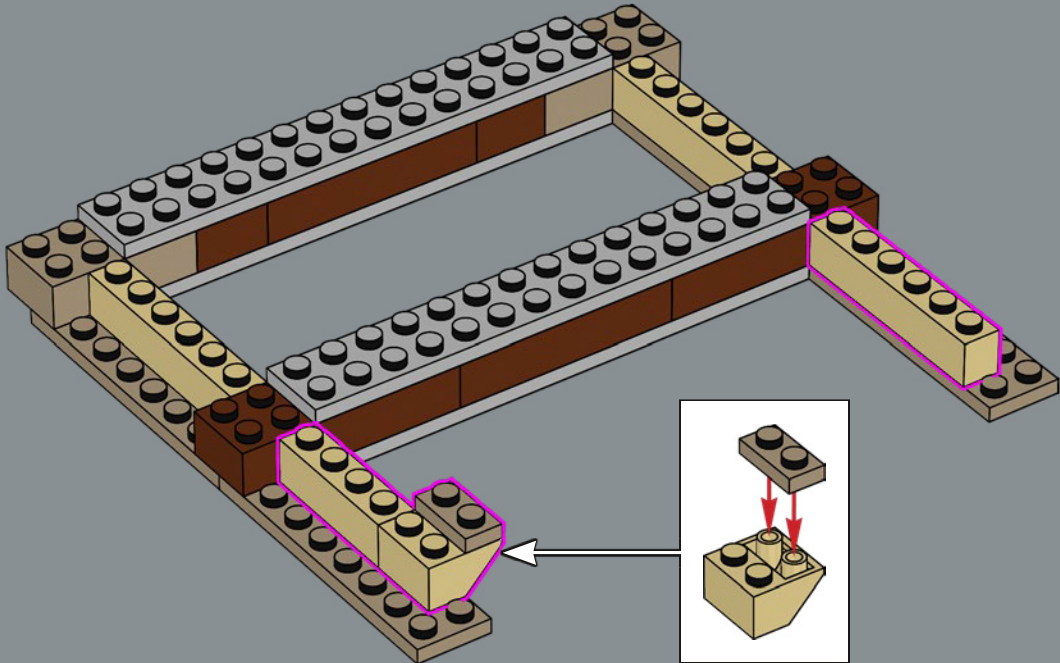

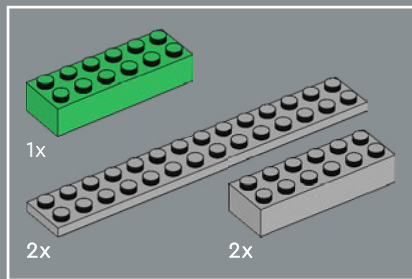

48

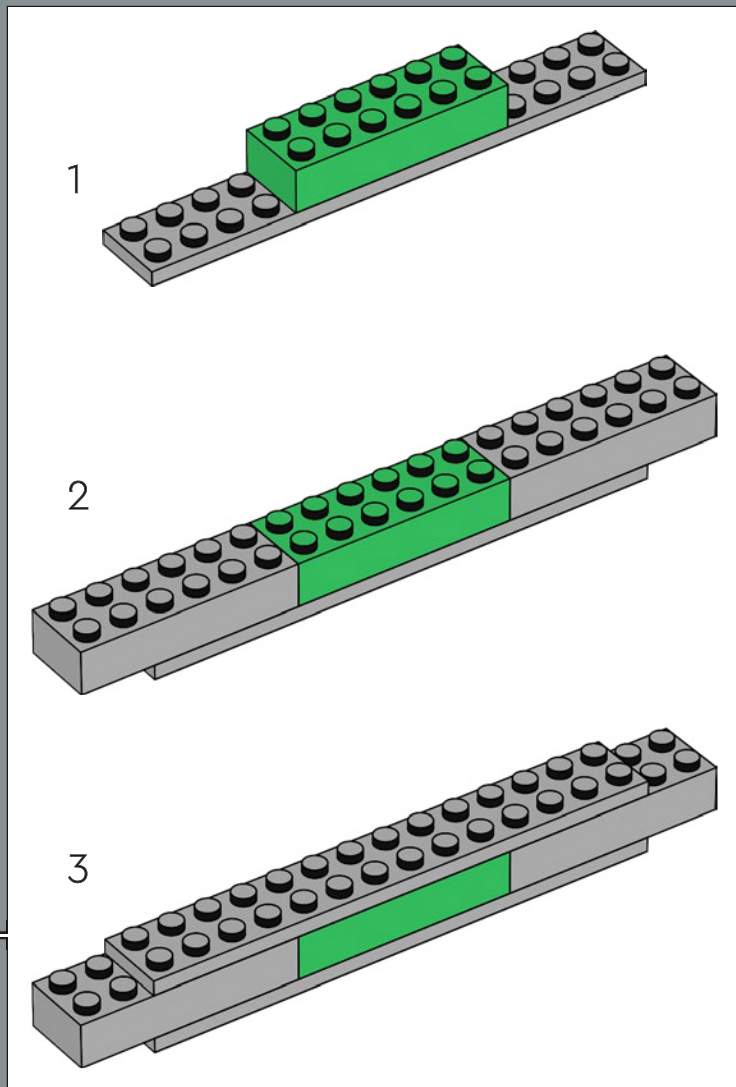
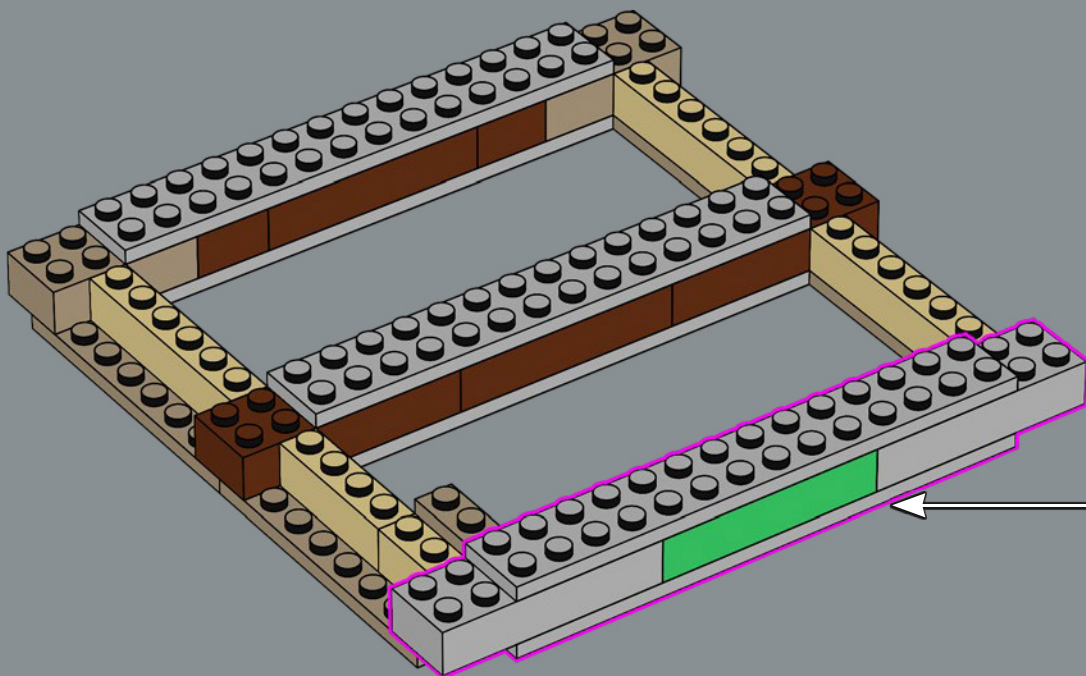

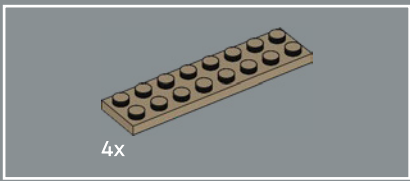

49

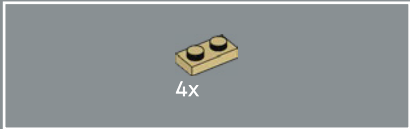
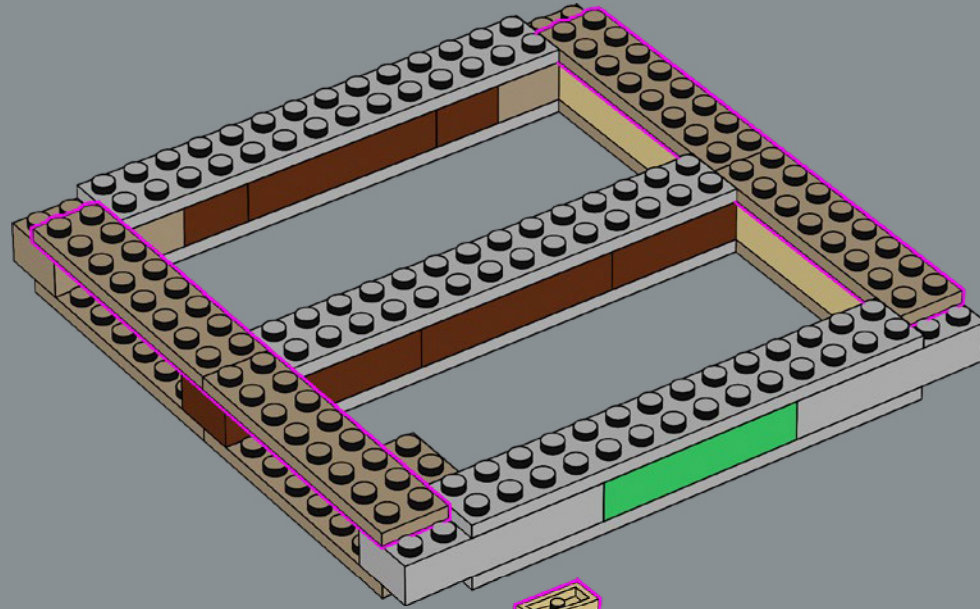

50

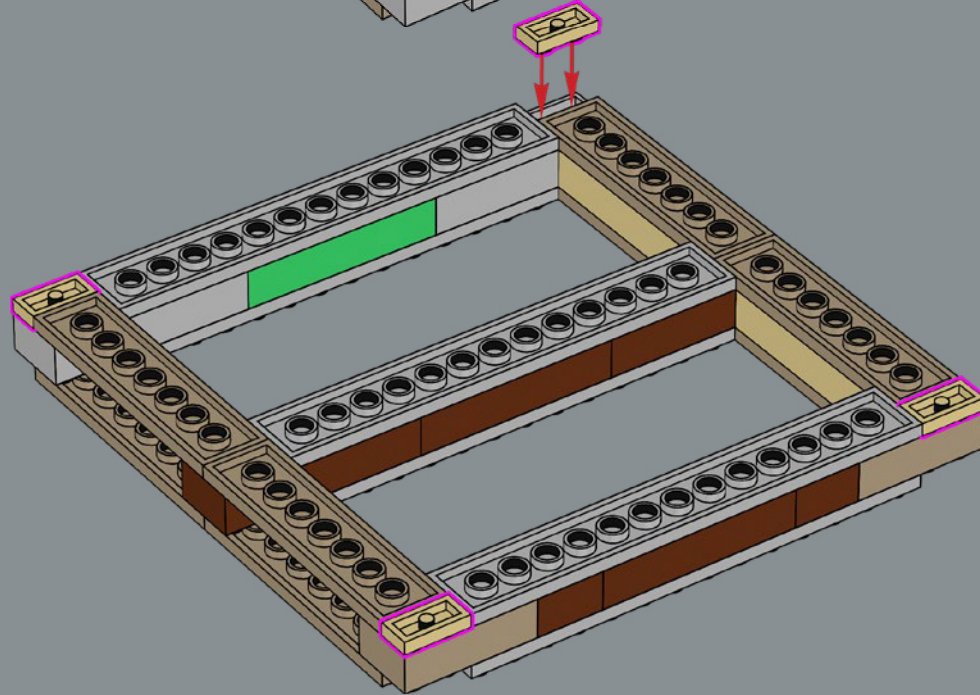



51

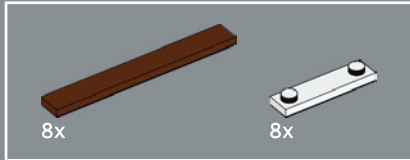
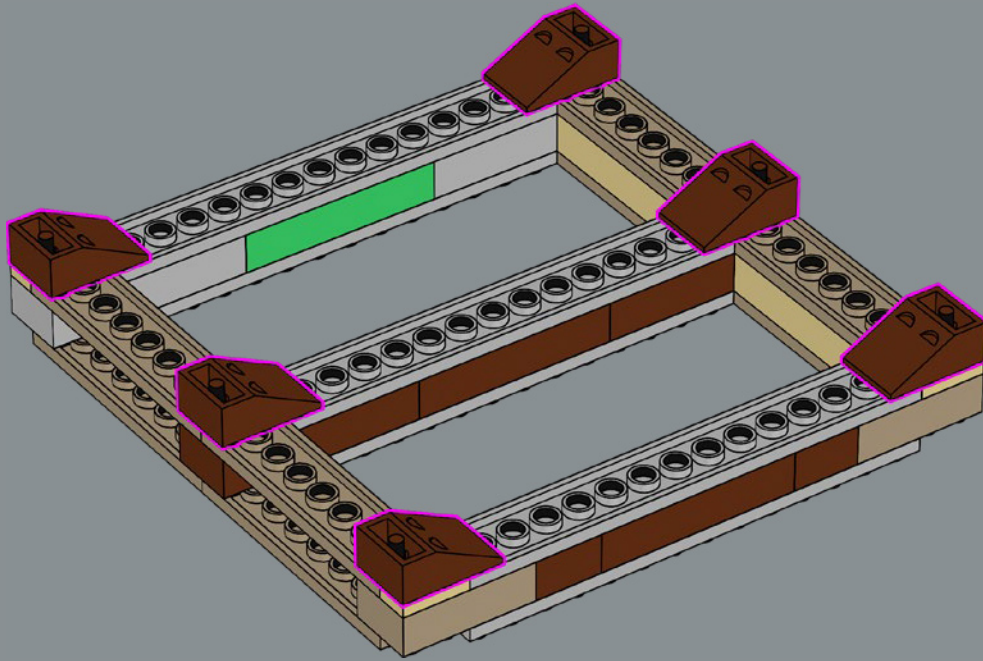

52

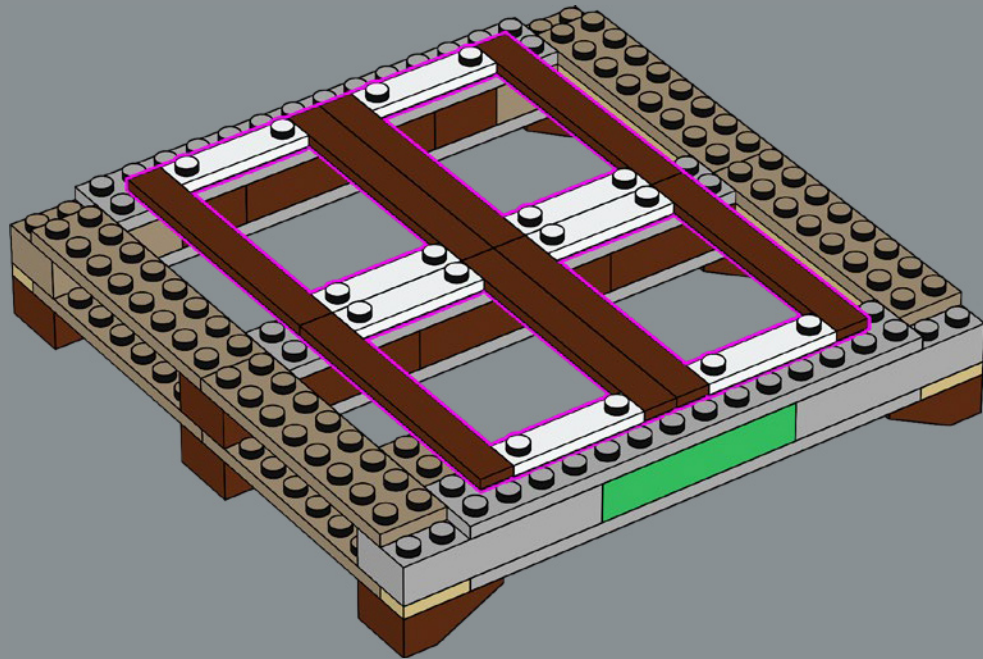

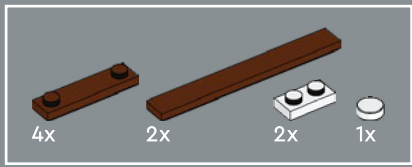

53

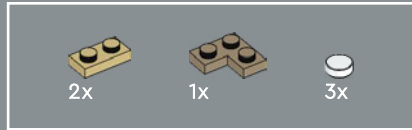
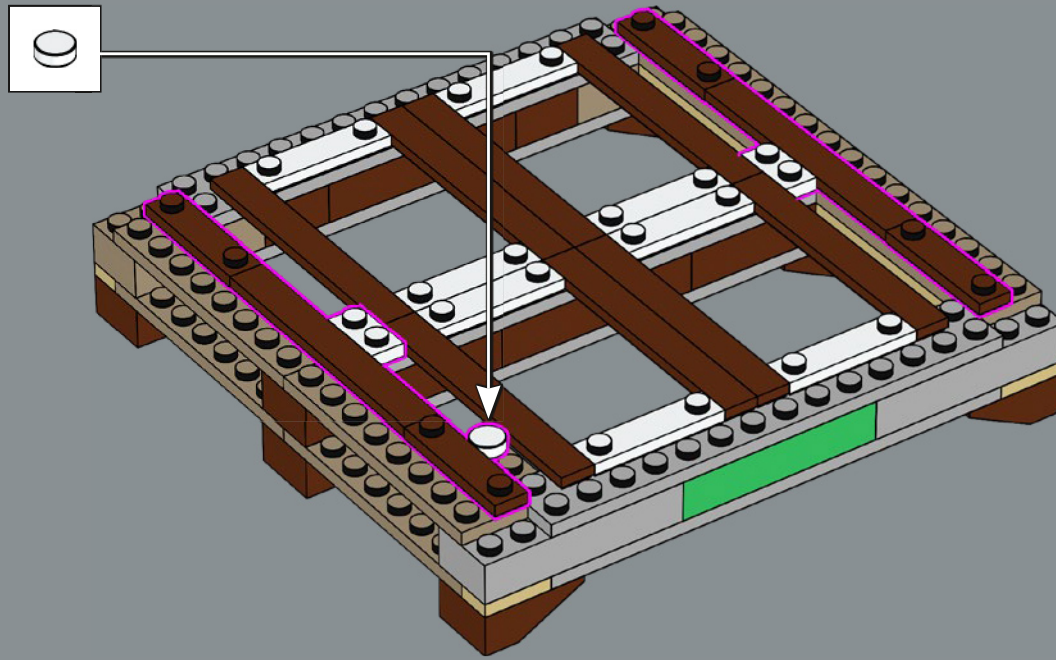

54

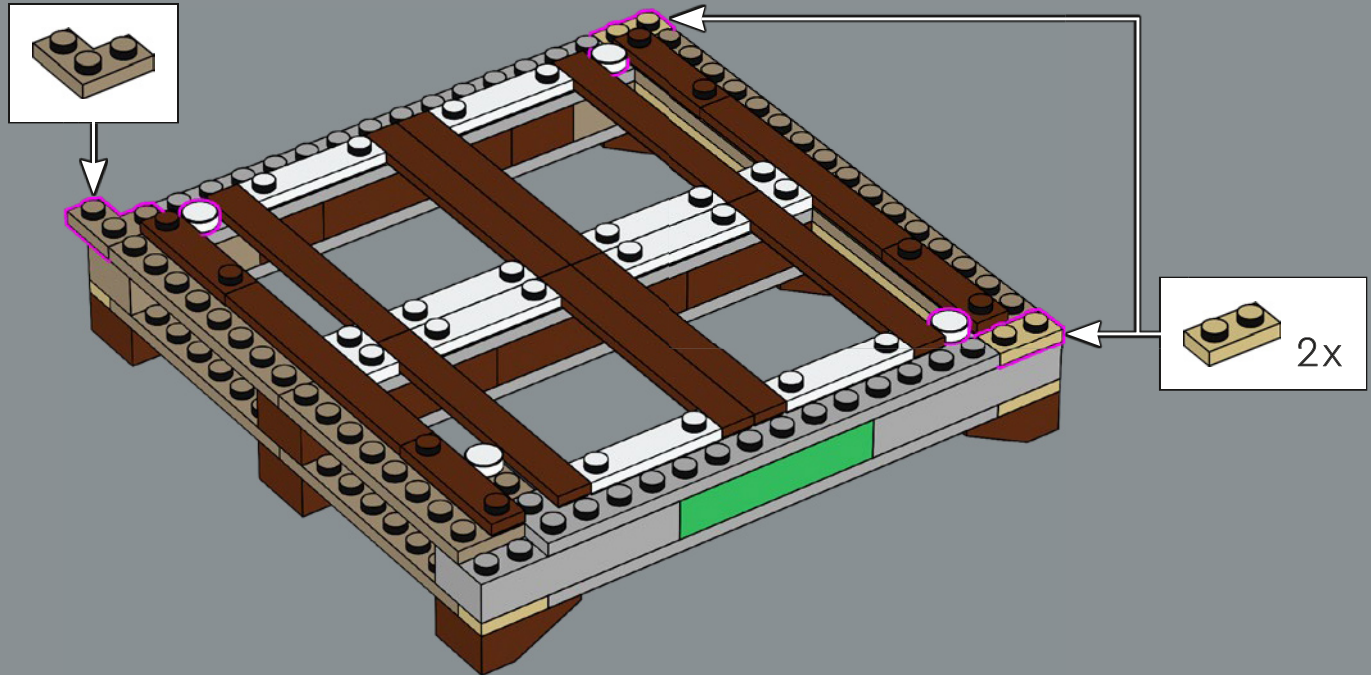

55

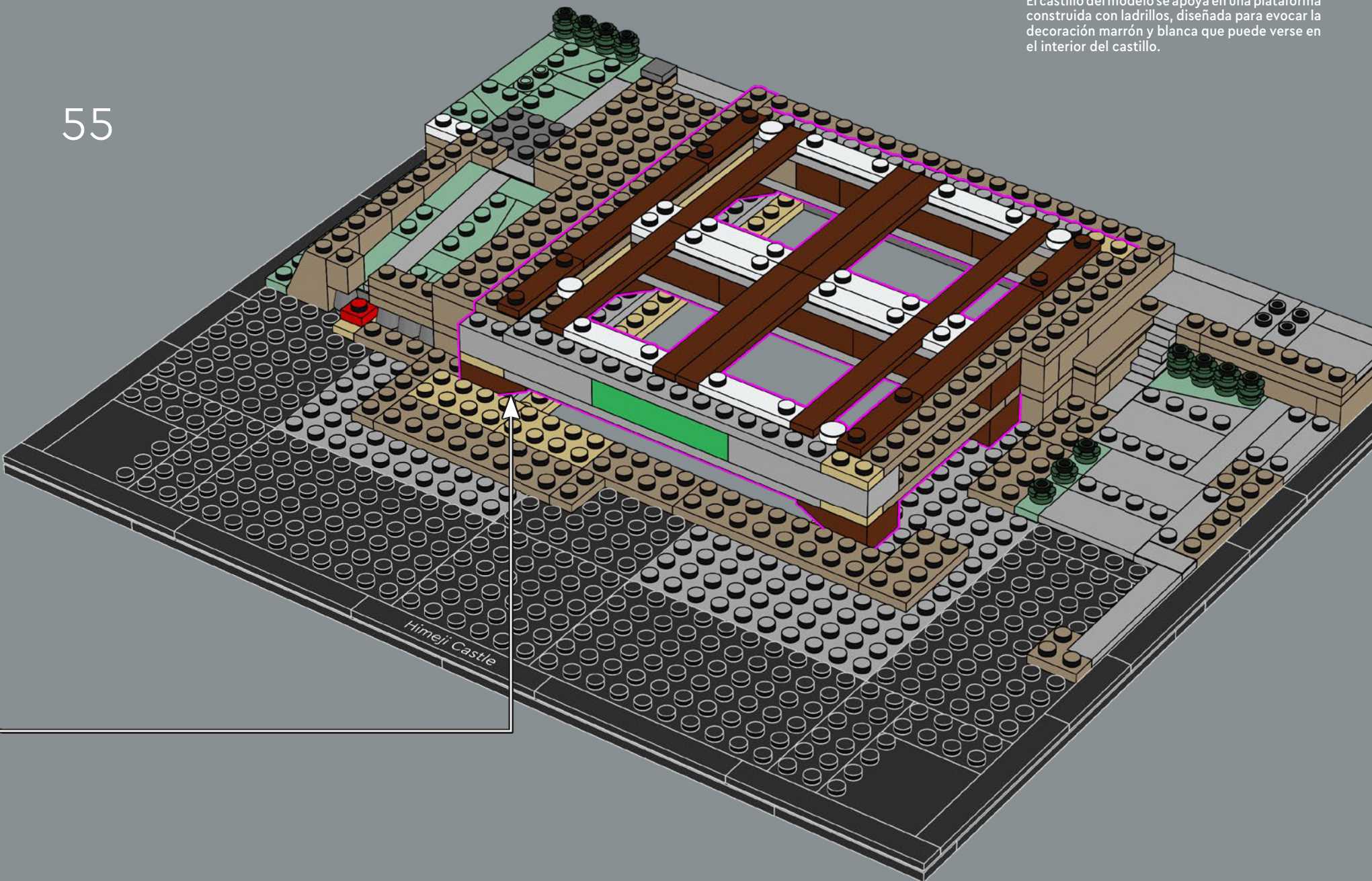

El castillo del modelo se apoya en una plataforma construida con ladrillos, diseñada para evocar la decoración marrón y blanca que puede verse en el interior del castillo.

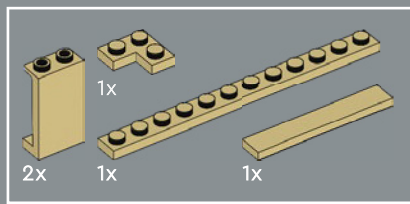

56

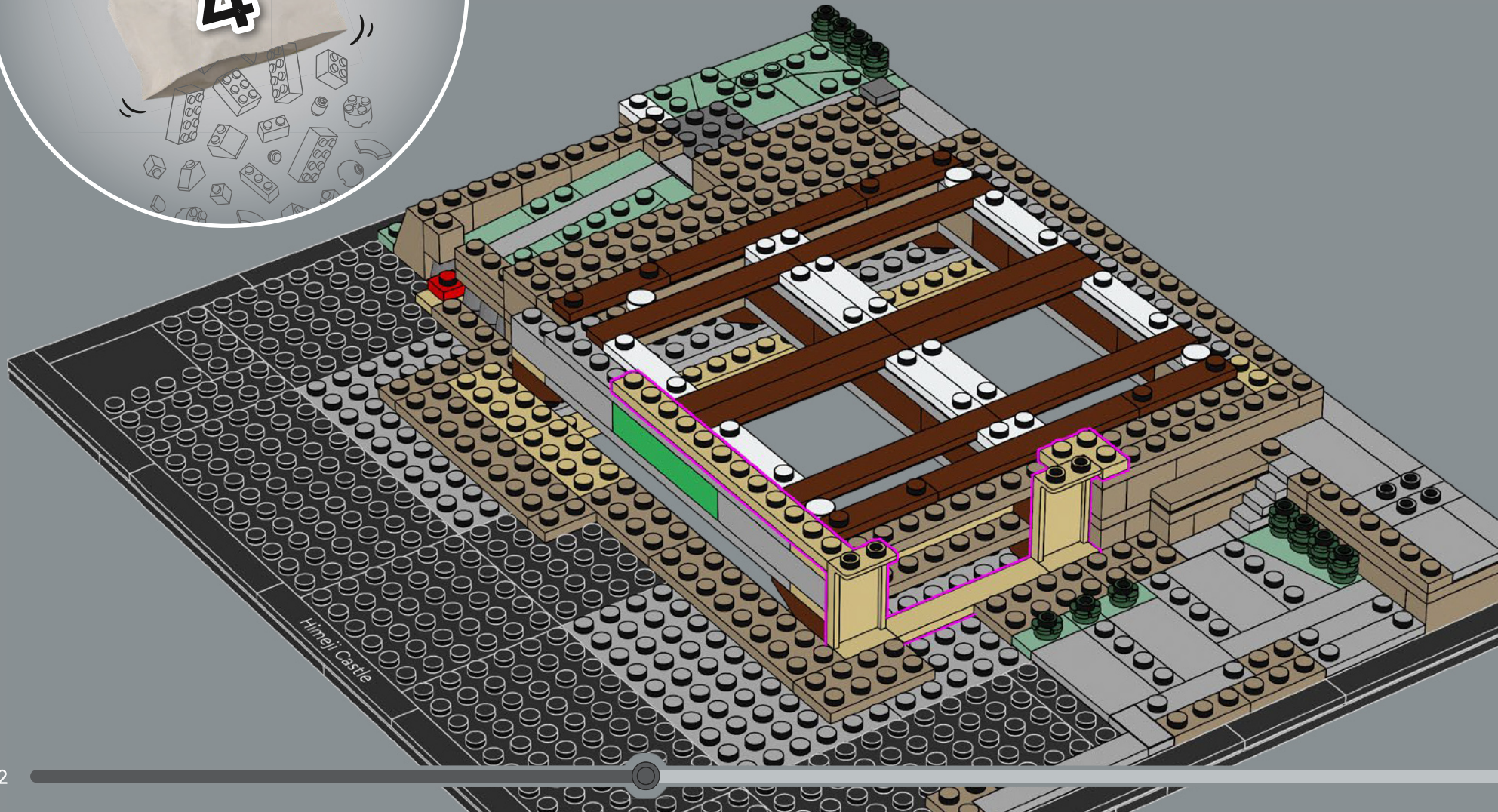

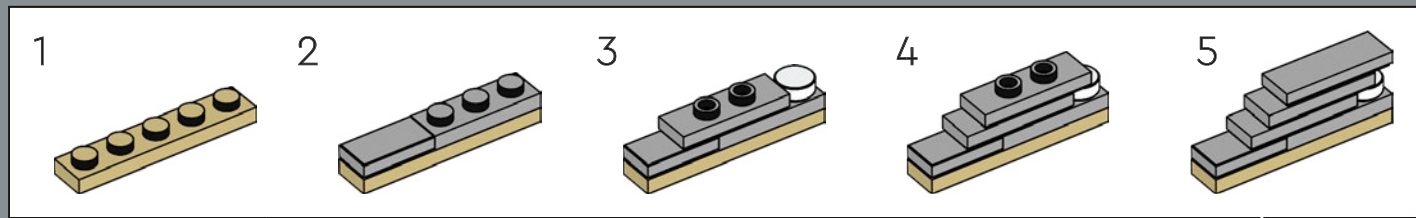
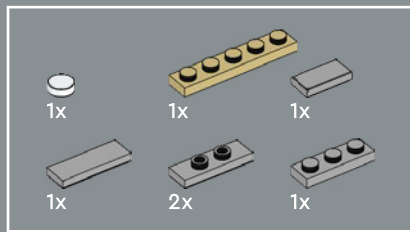

57

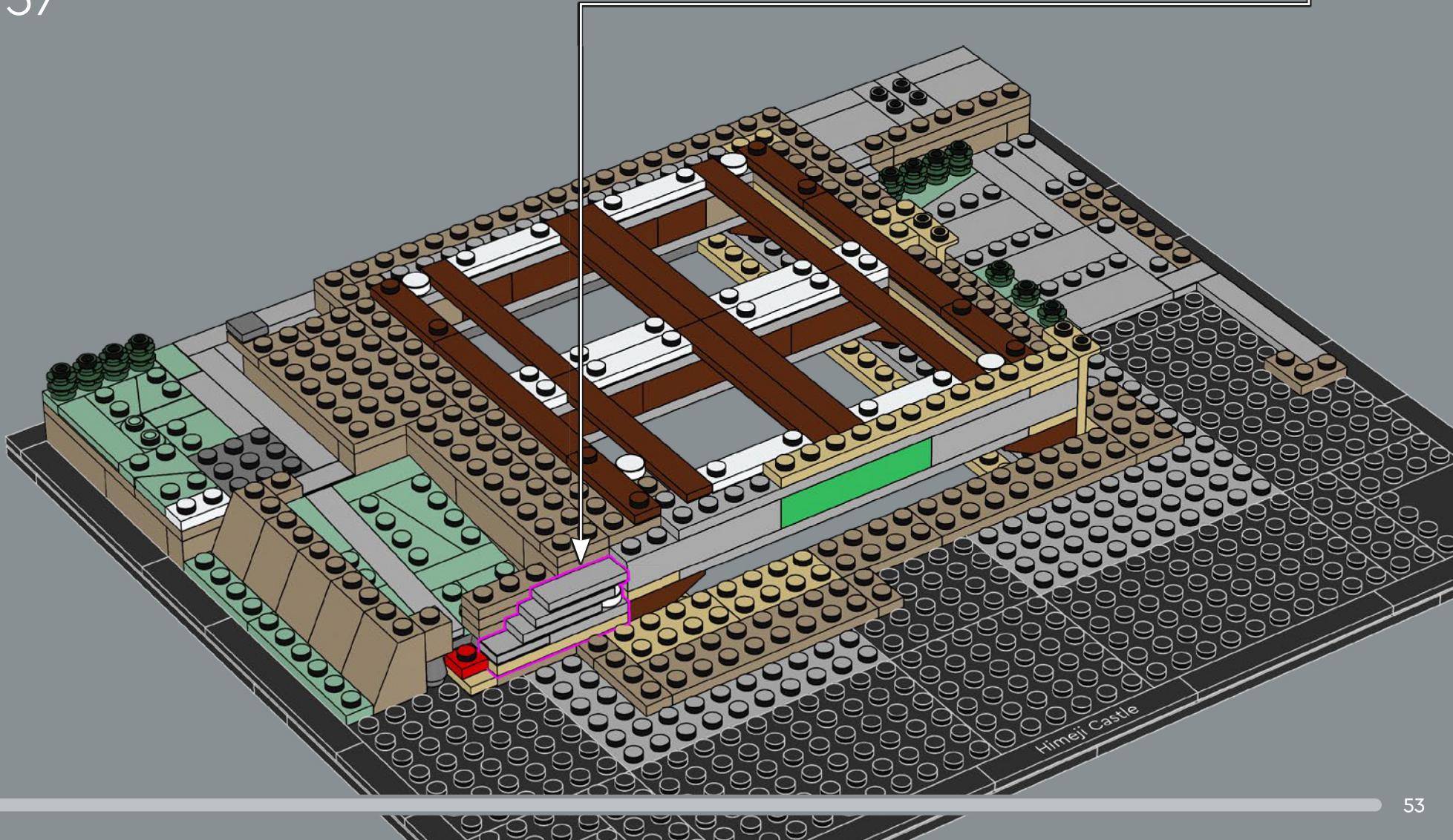

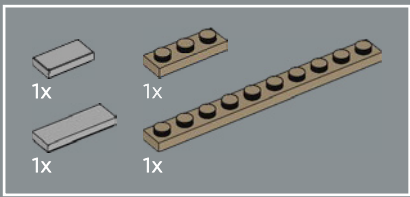

58

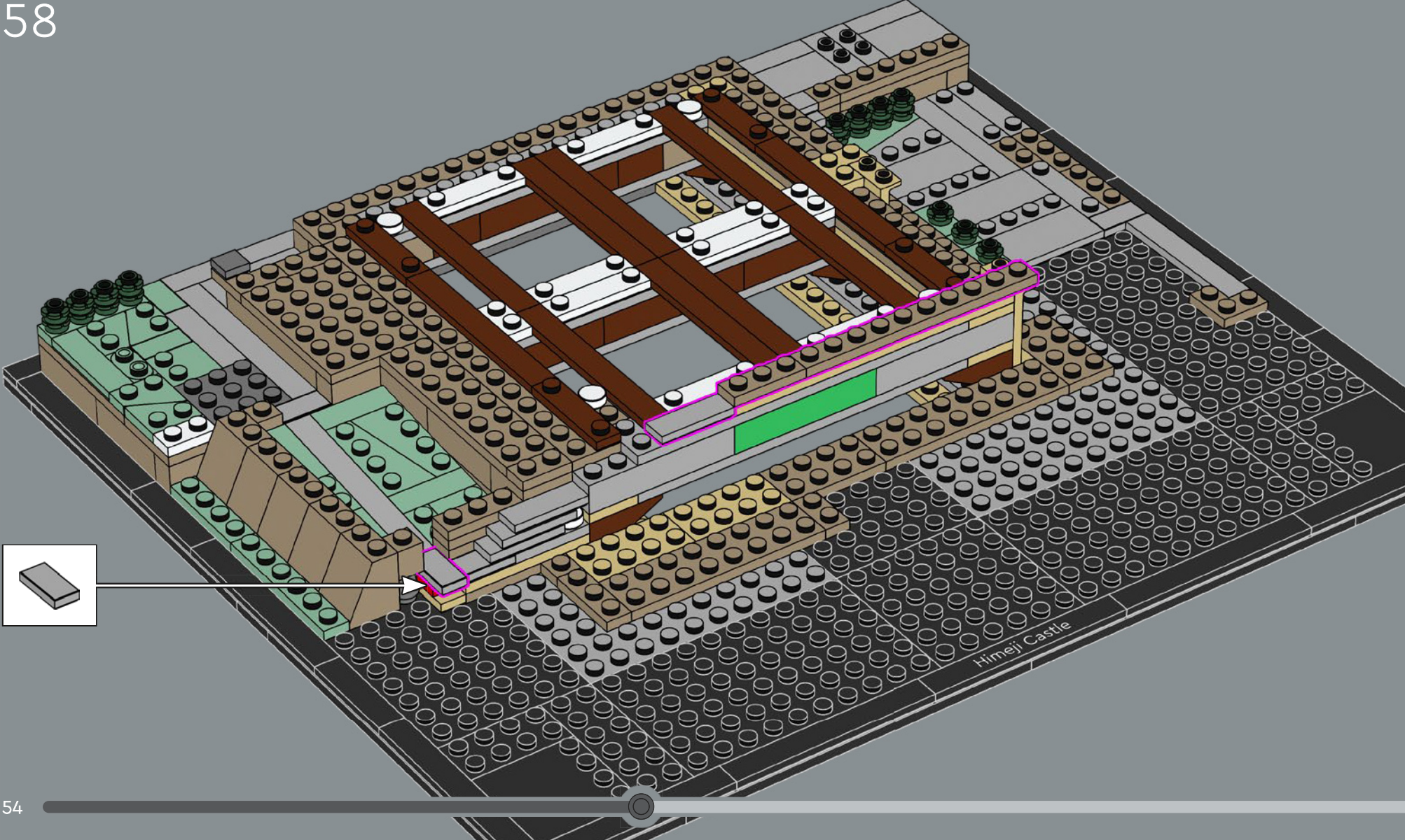

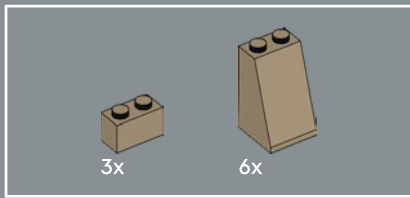

59

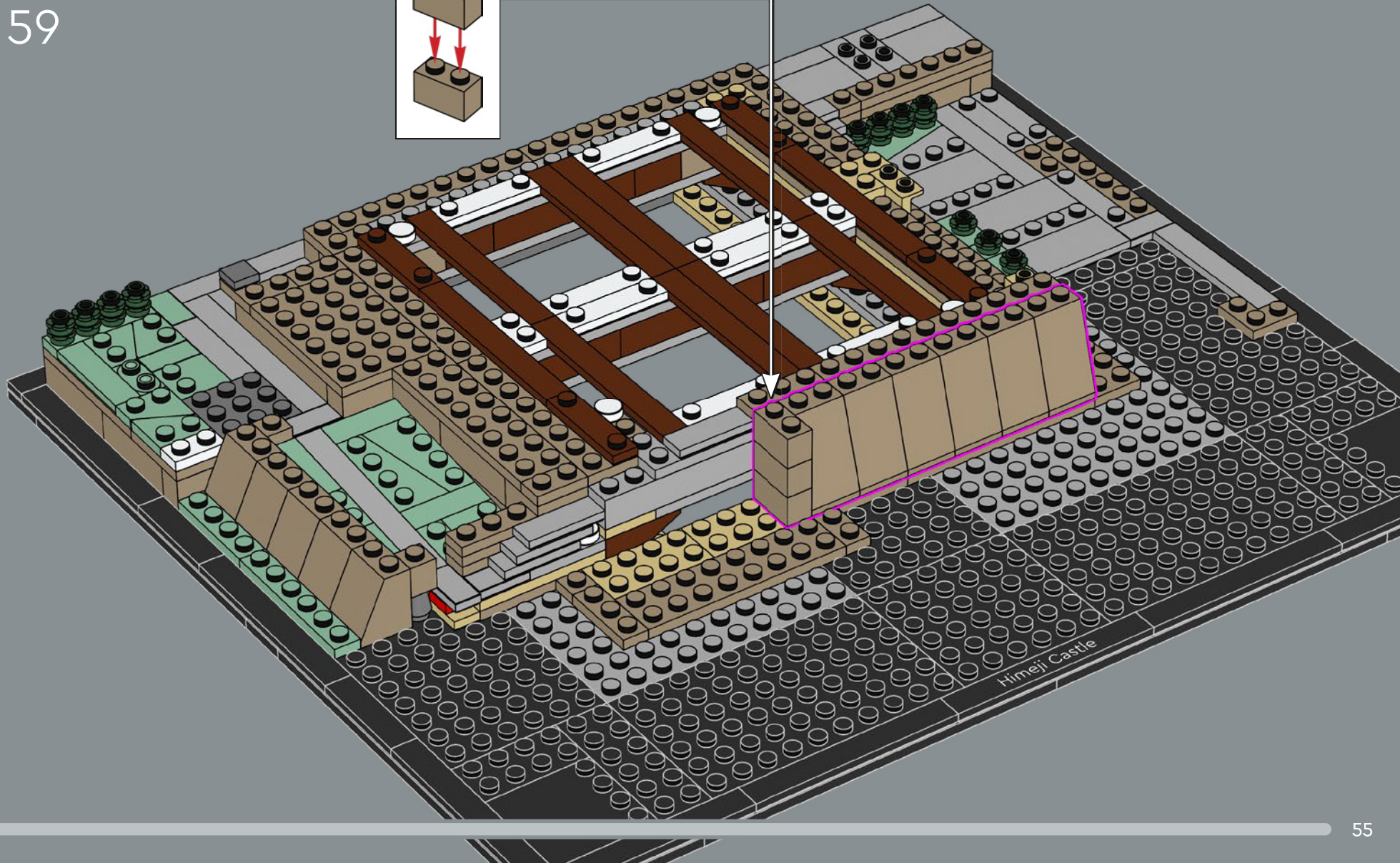
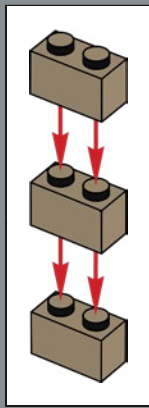

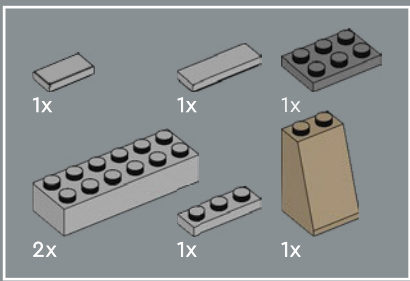

60

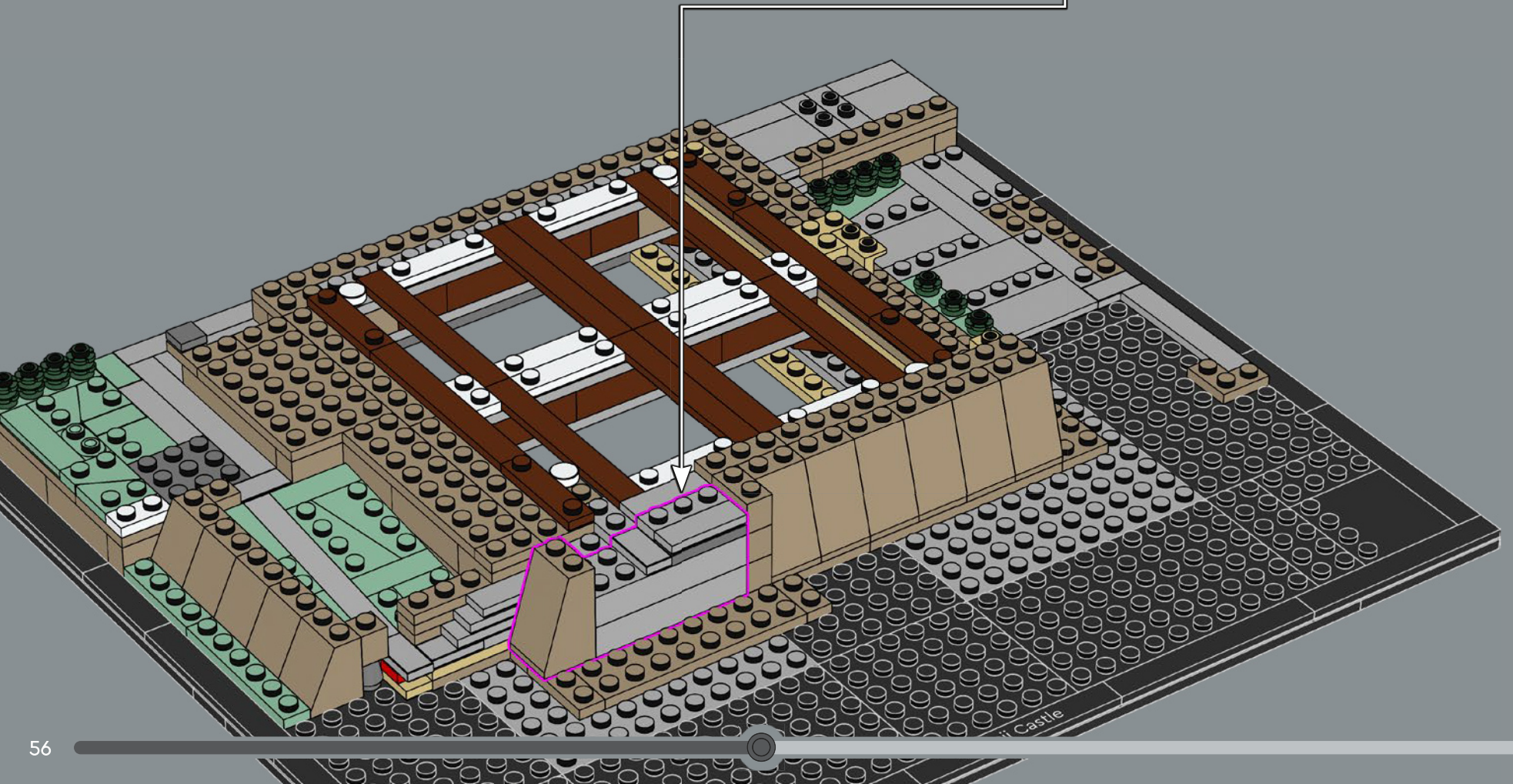
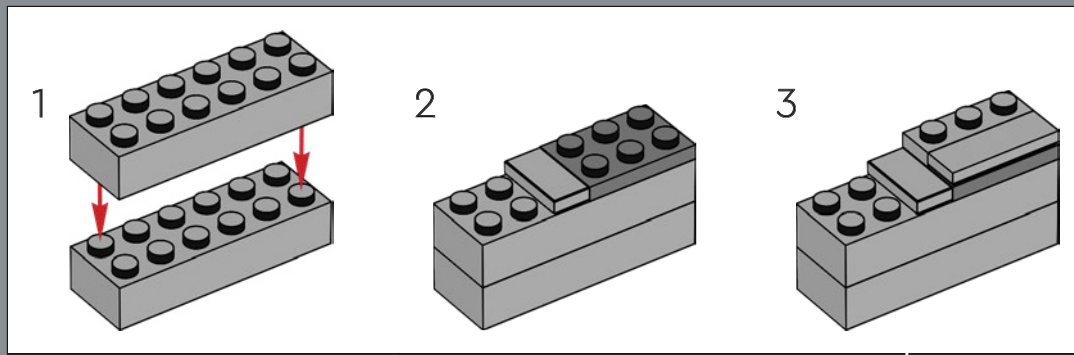

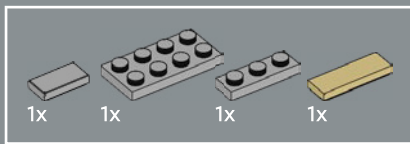

61

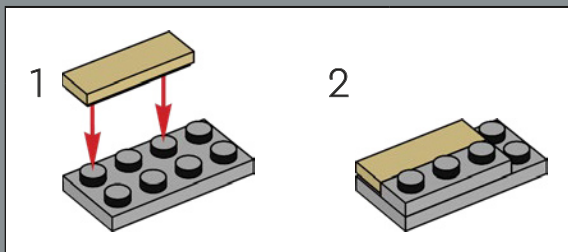
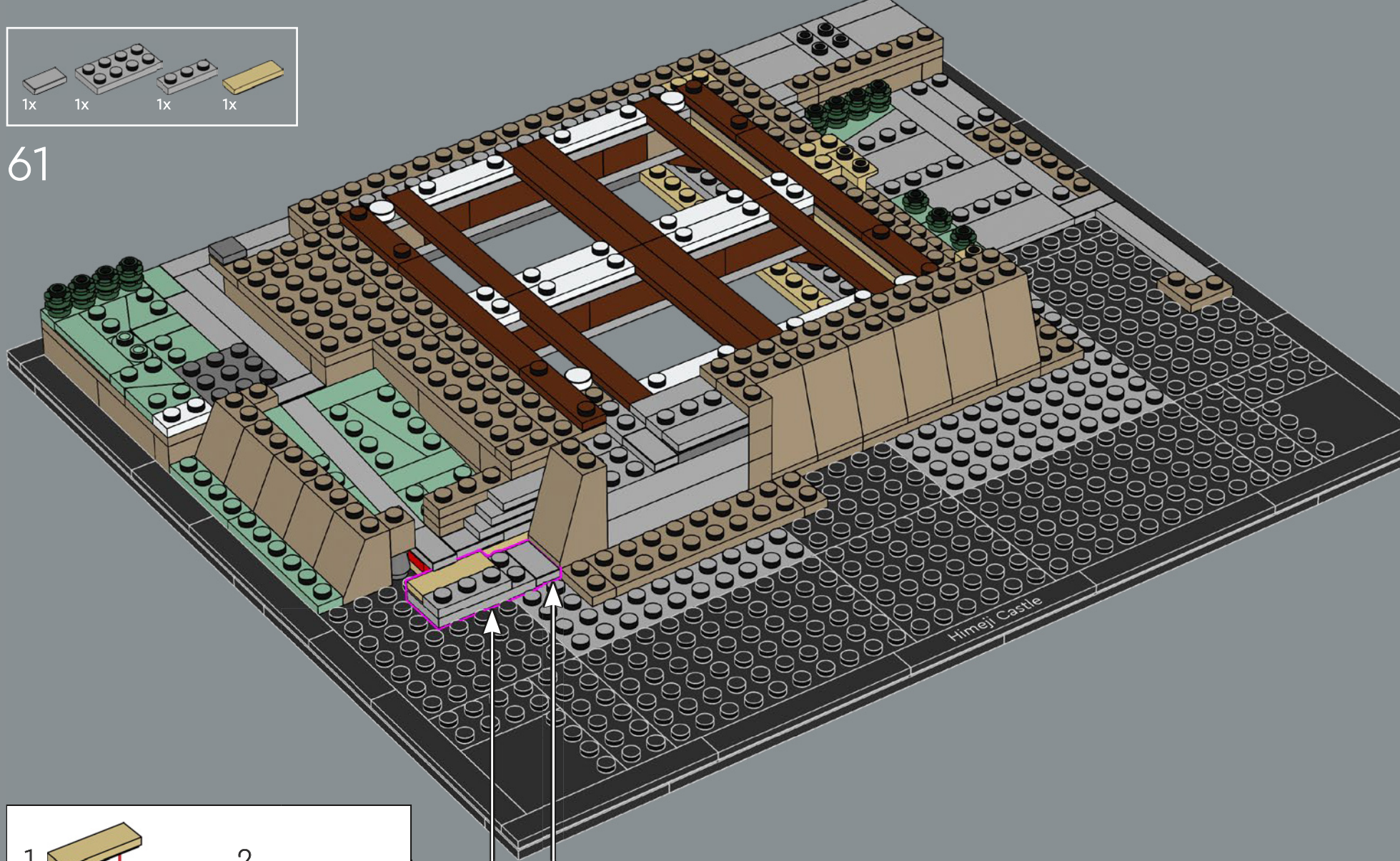

Himeji Castle

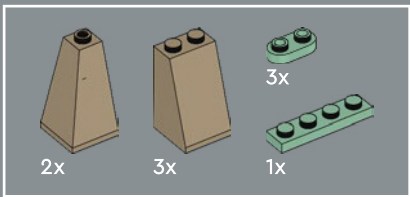

62

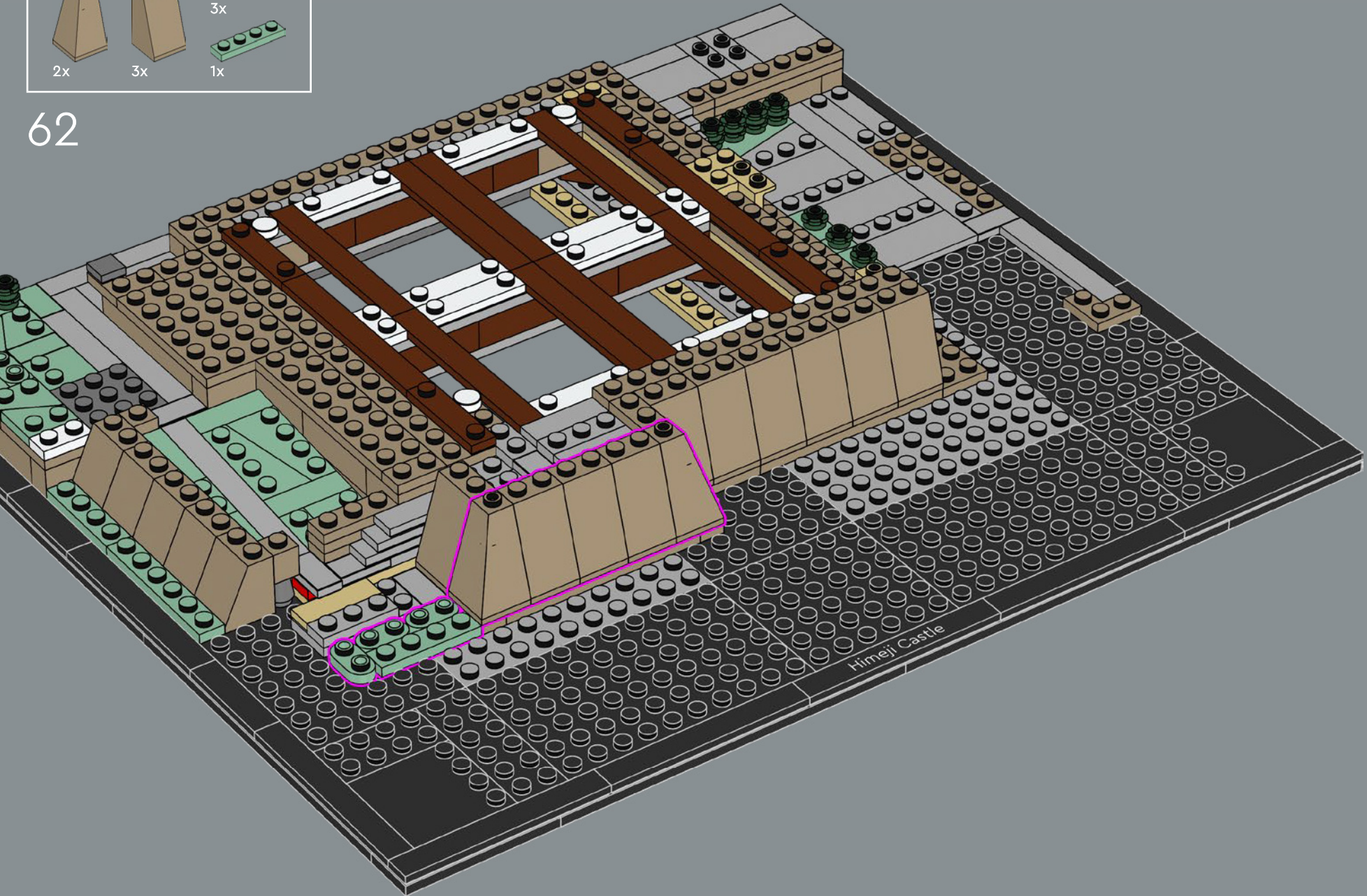

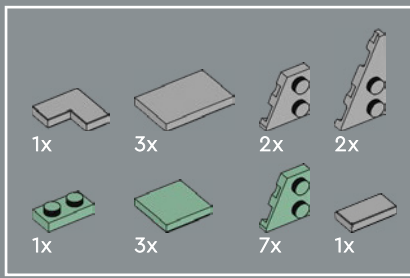

63

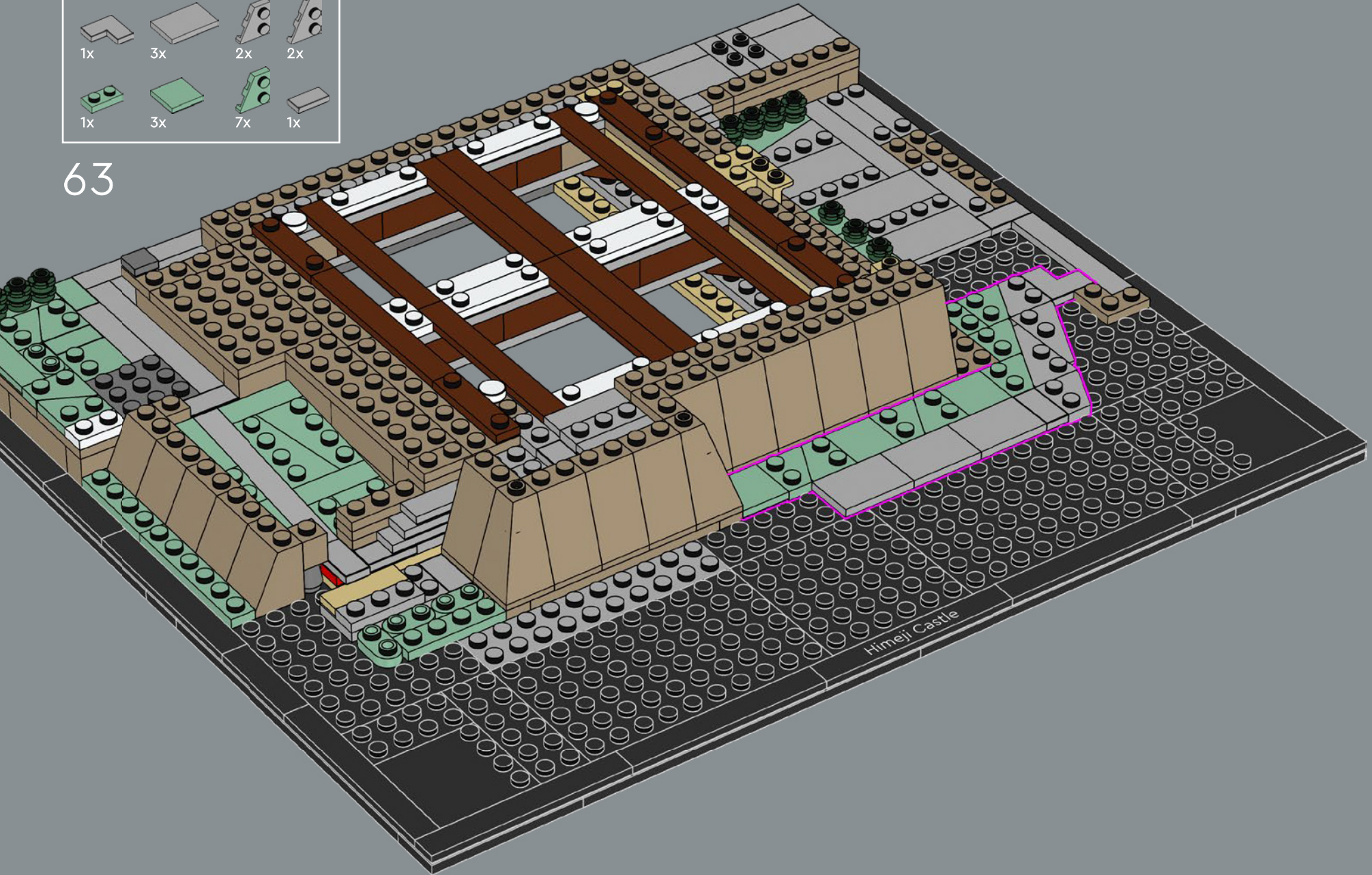

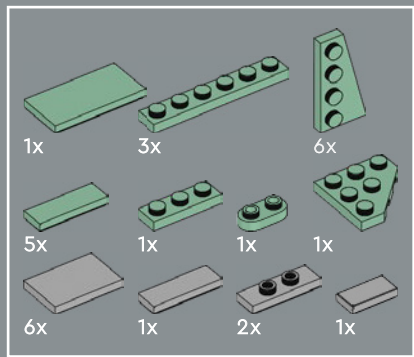

64

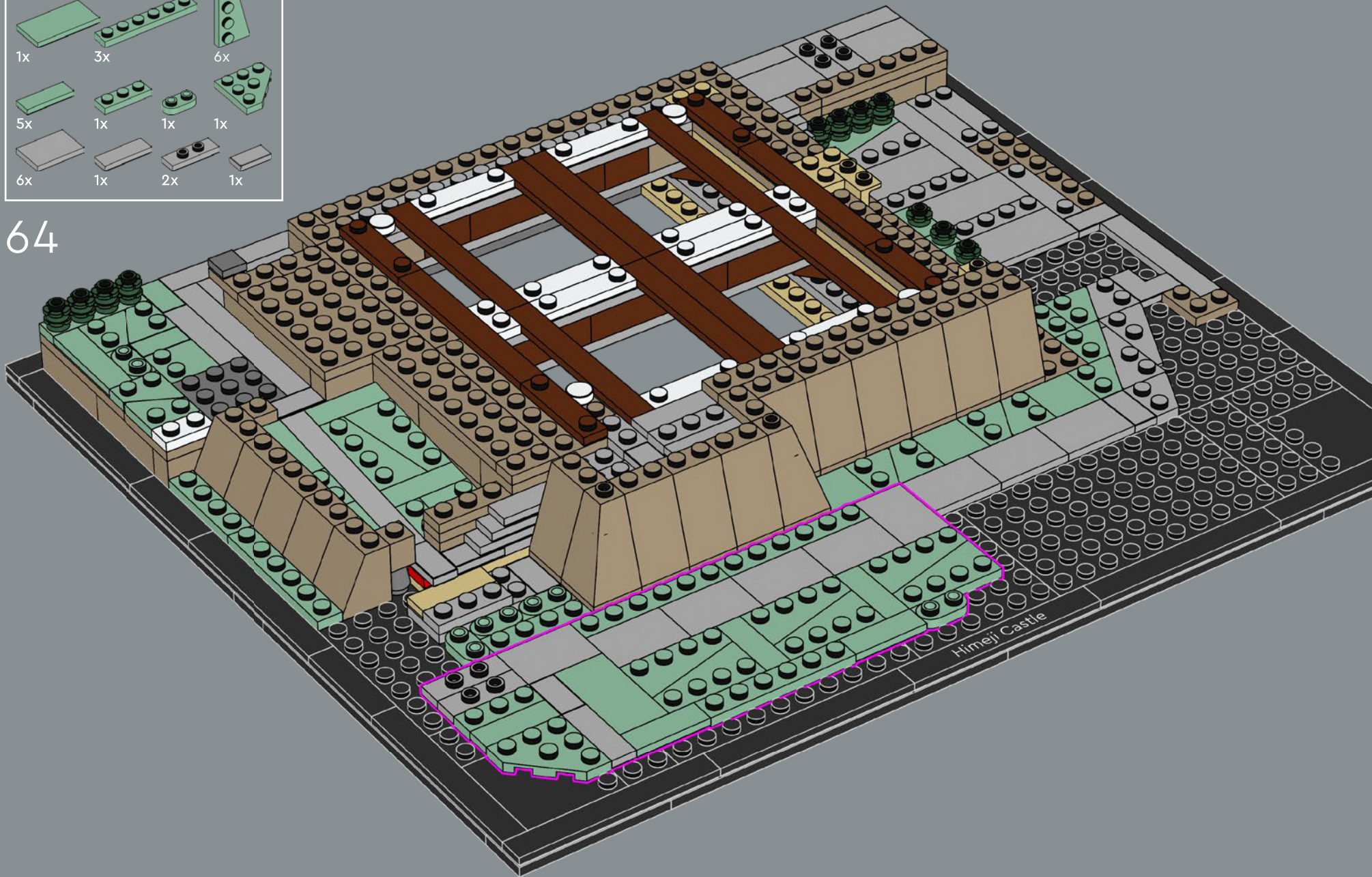

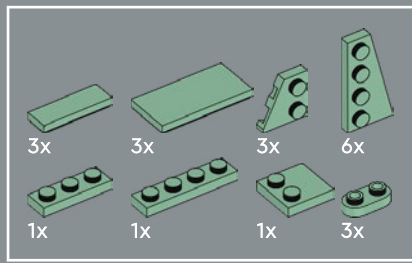

65

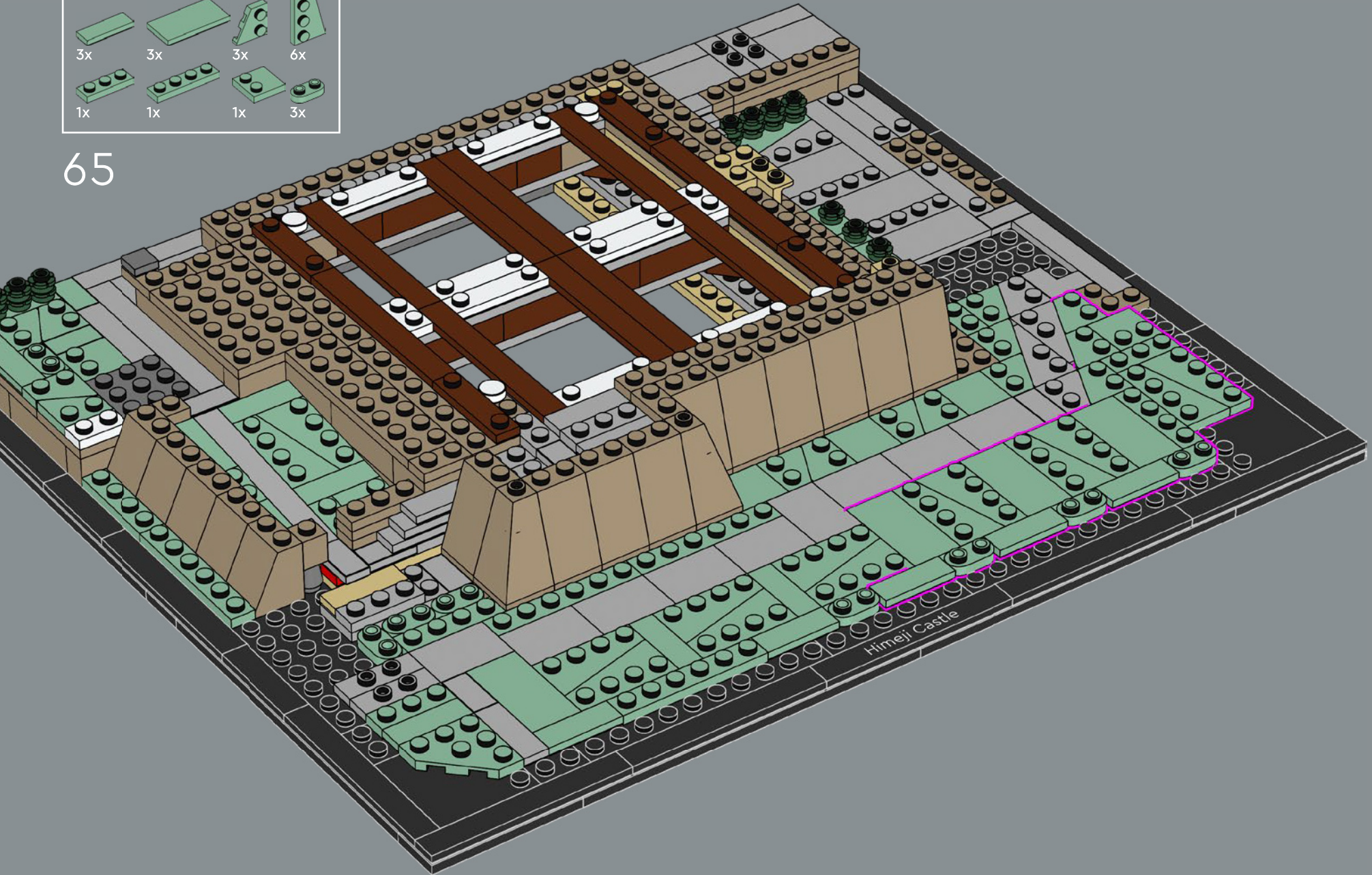

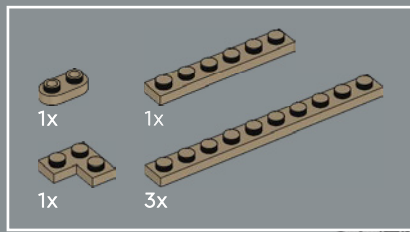

66

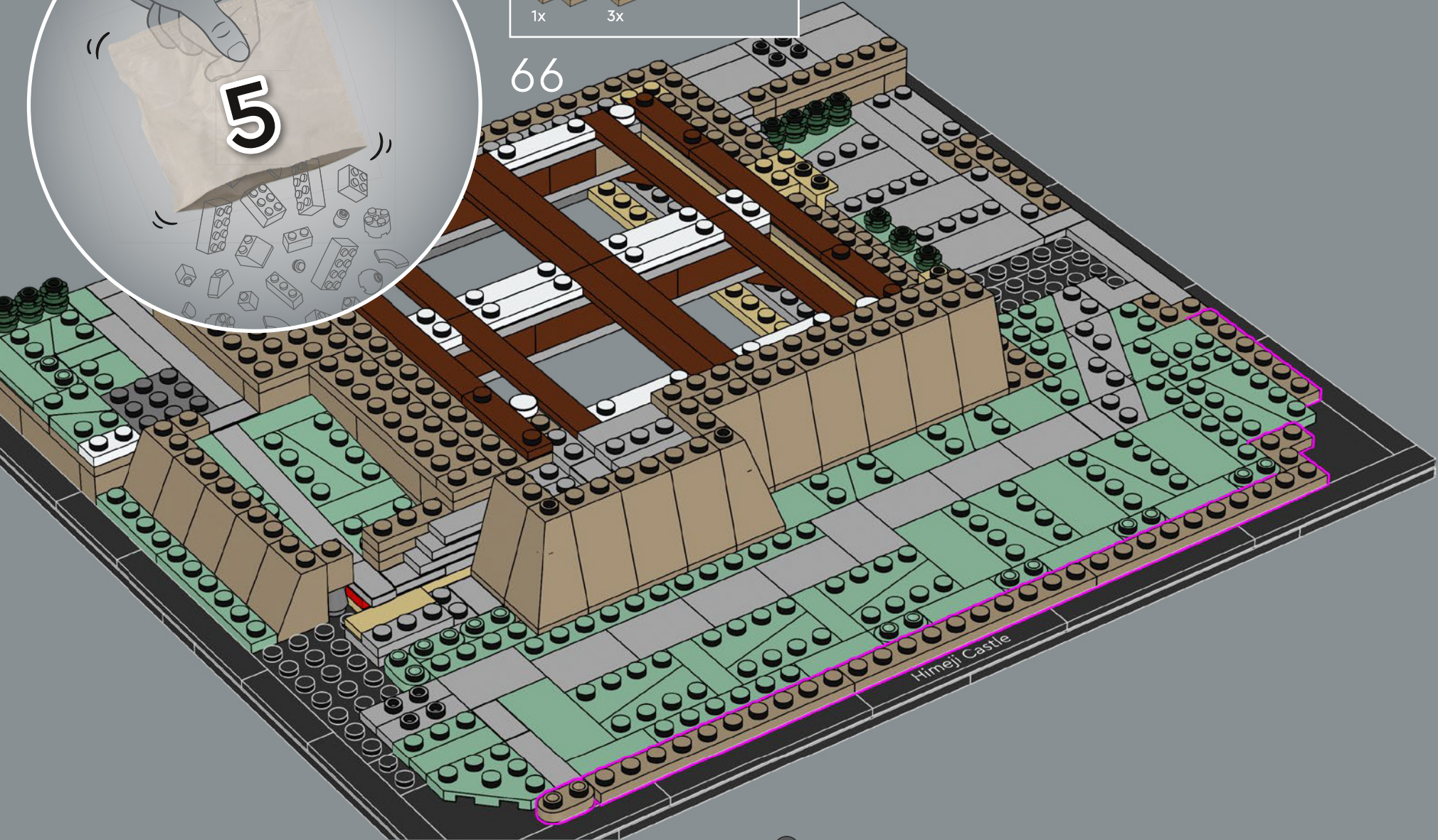

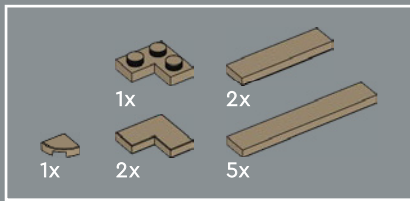

67

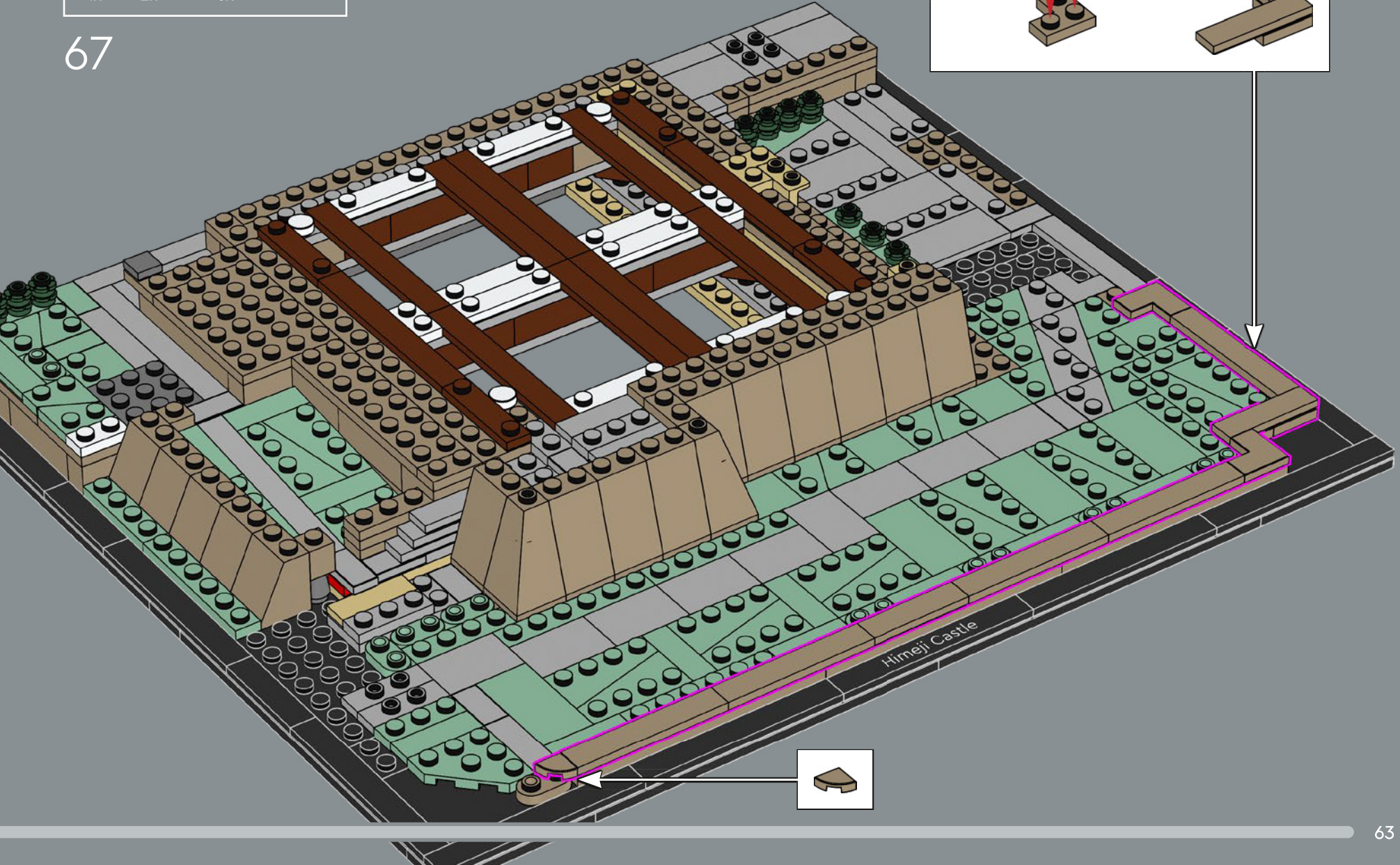
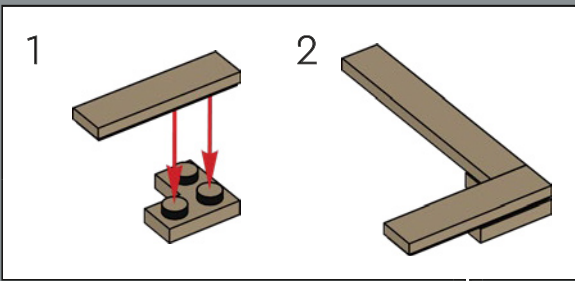

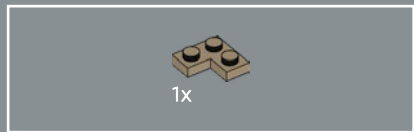

68

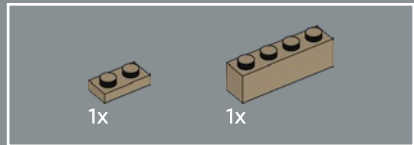
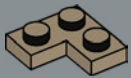

69

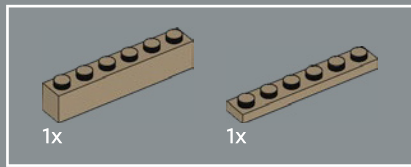
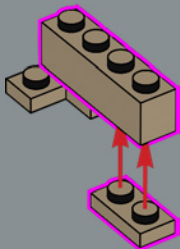

70

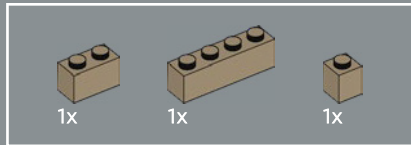
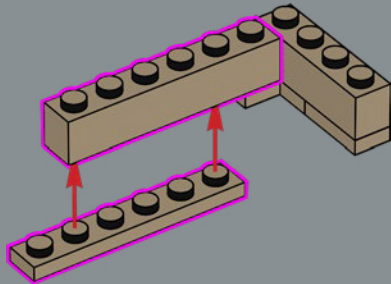

71

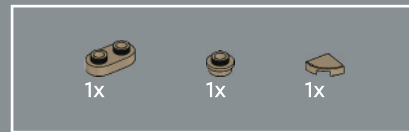
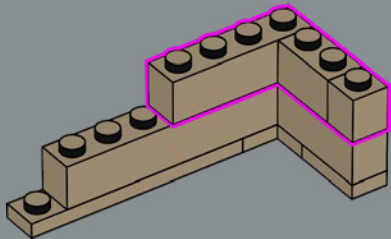

72

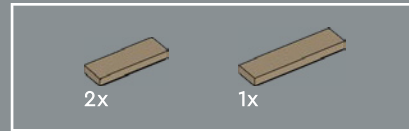
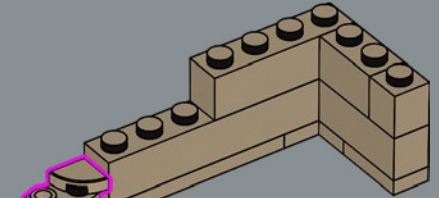
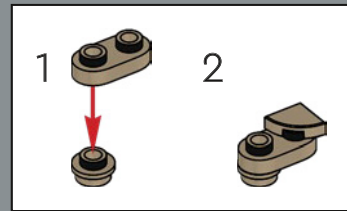

73

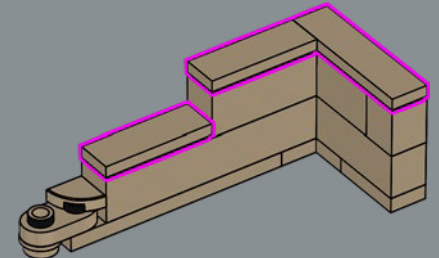

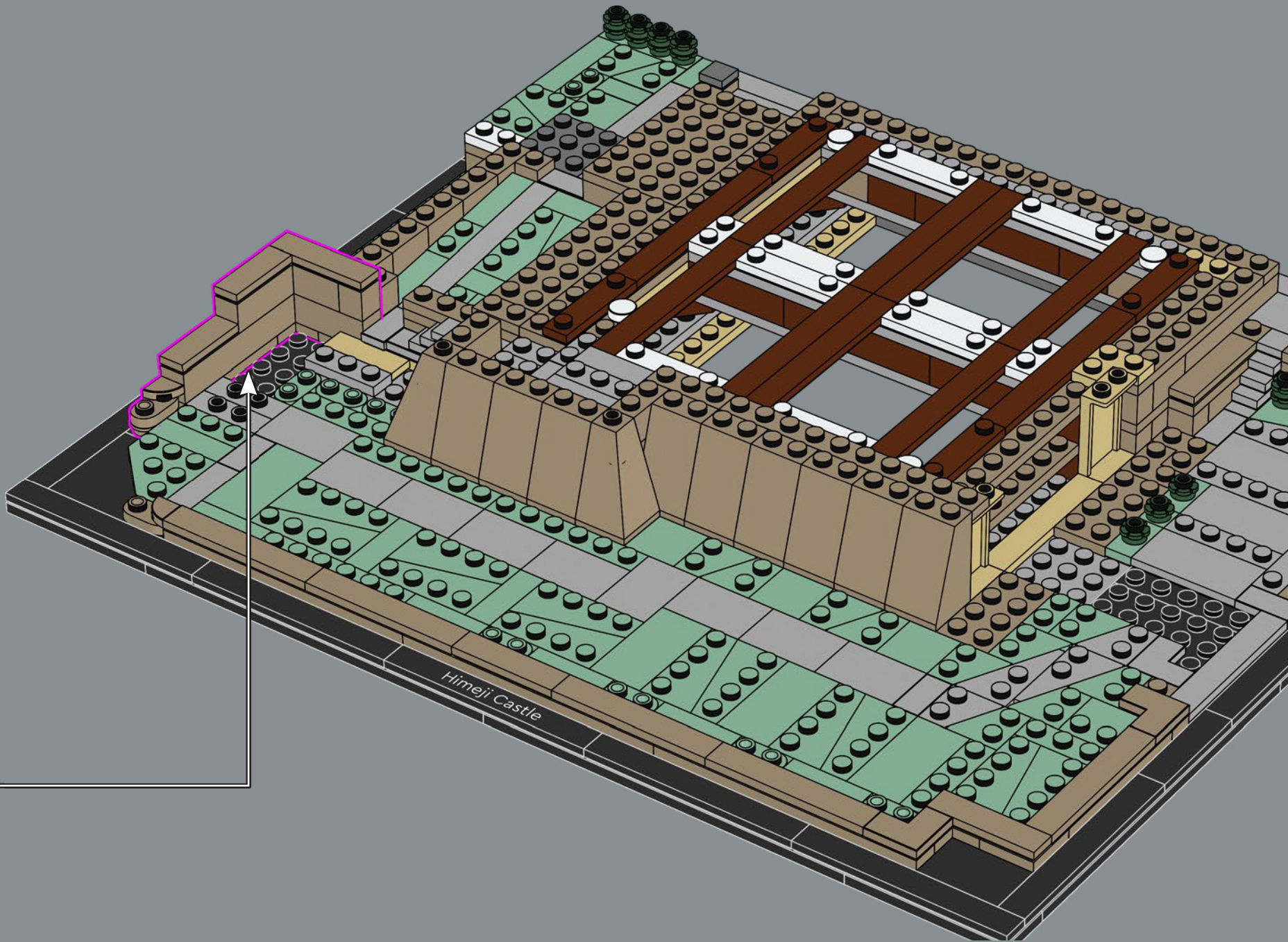

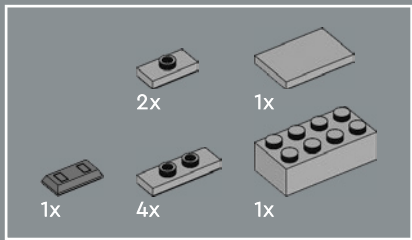

75

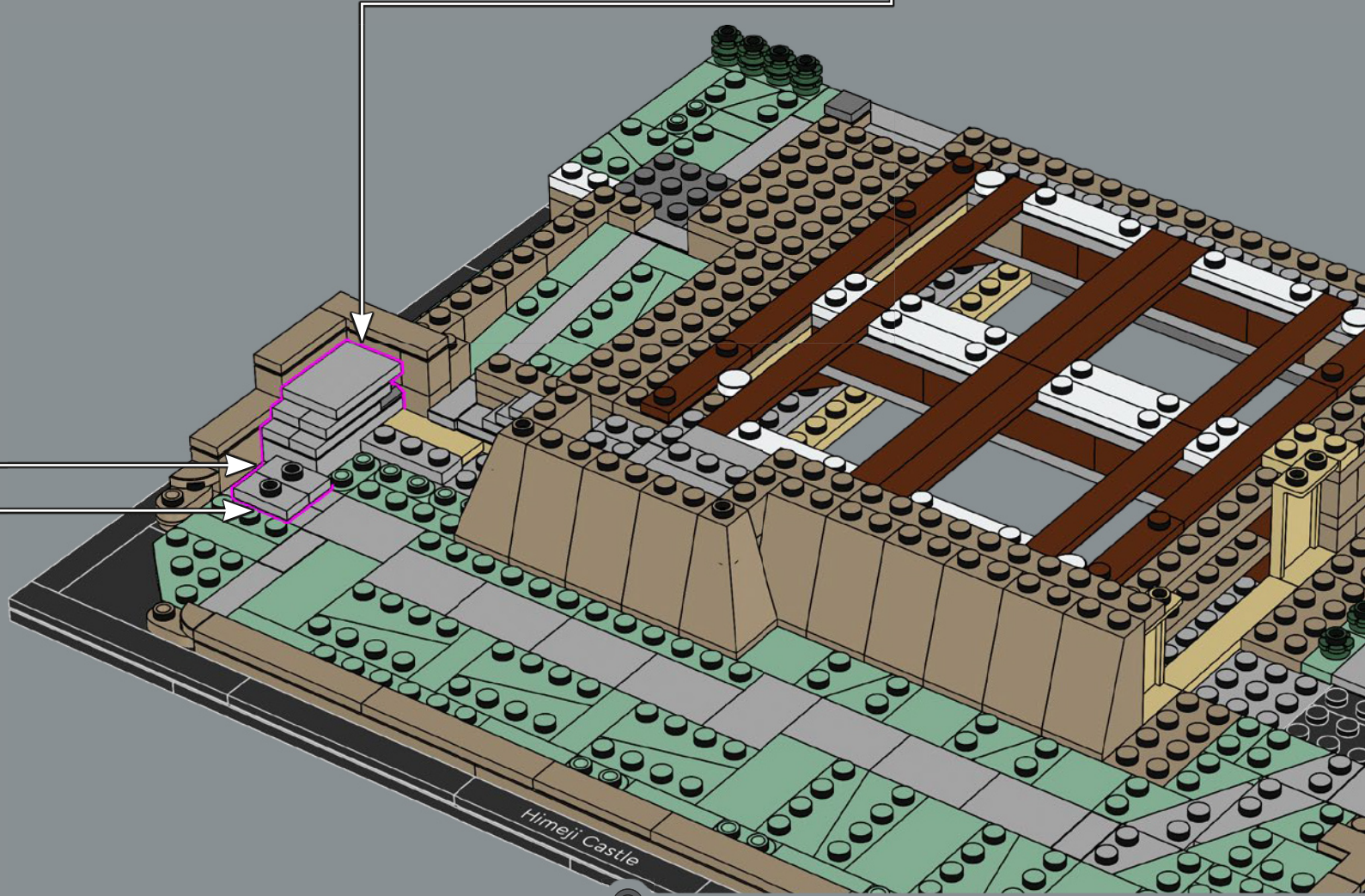
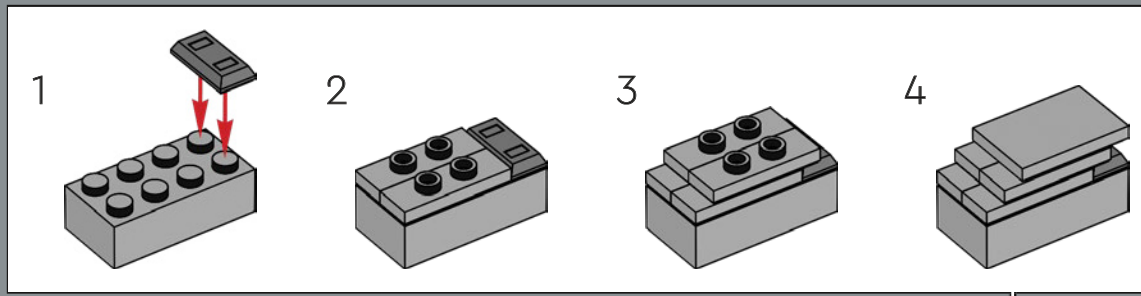

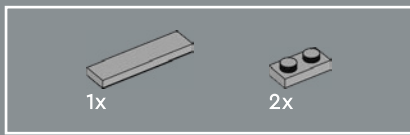

76

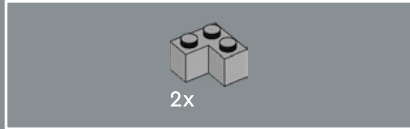
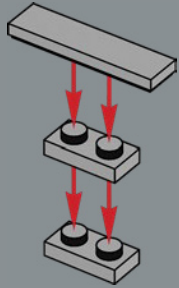

77

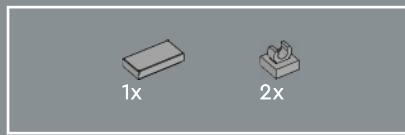
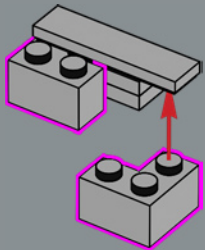

78

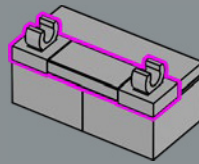

79

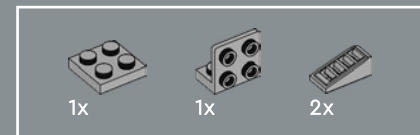
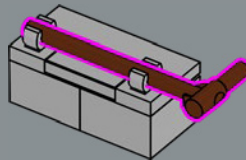

80

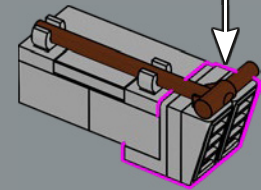
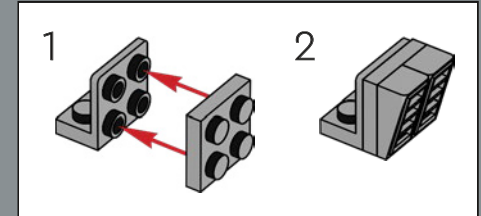

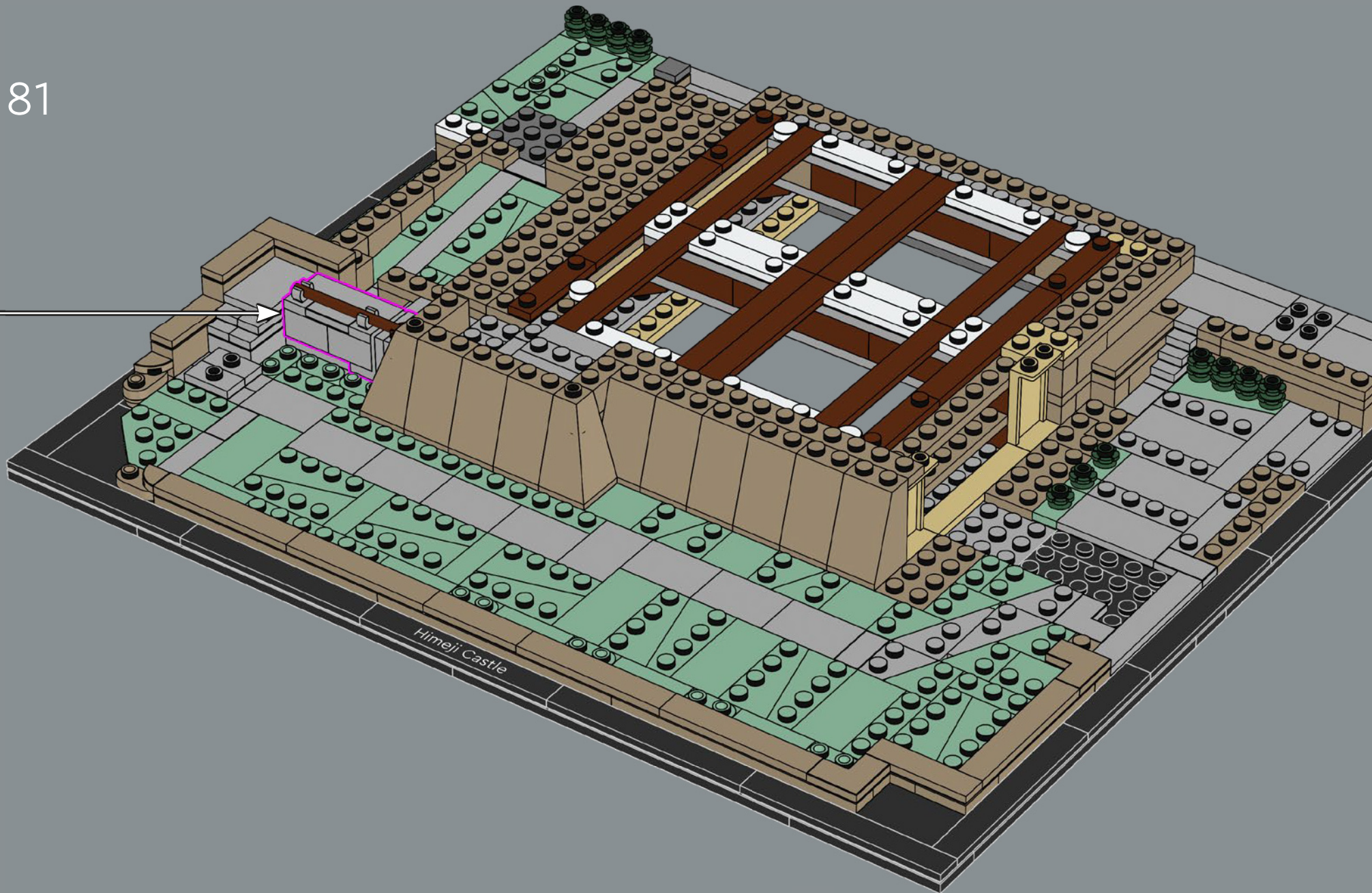

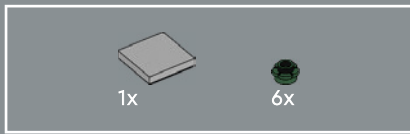

82

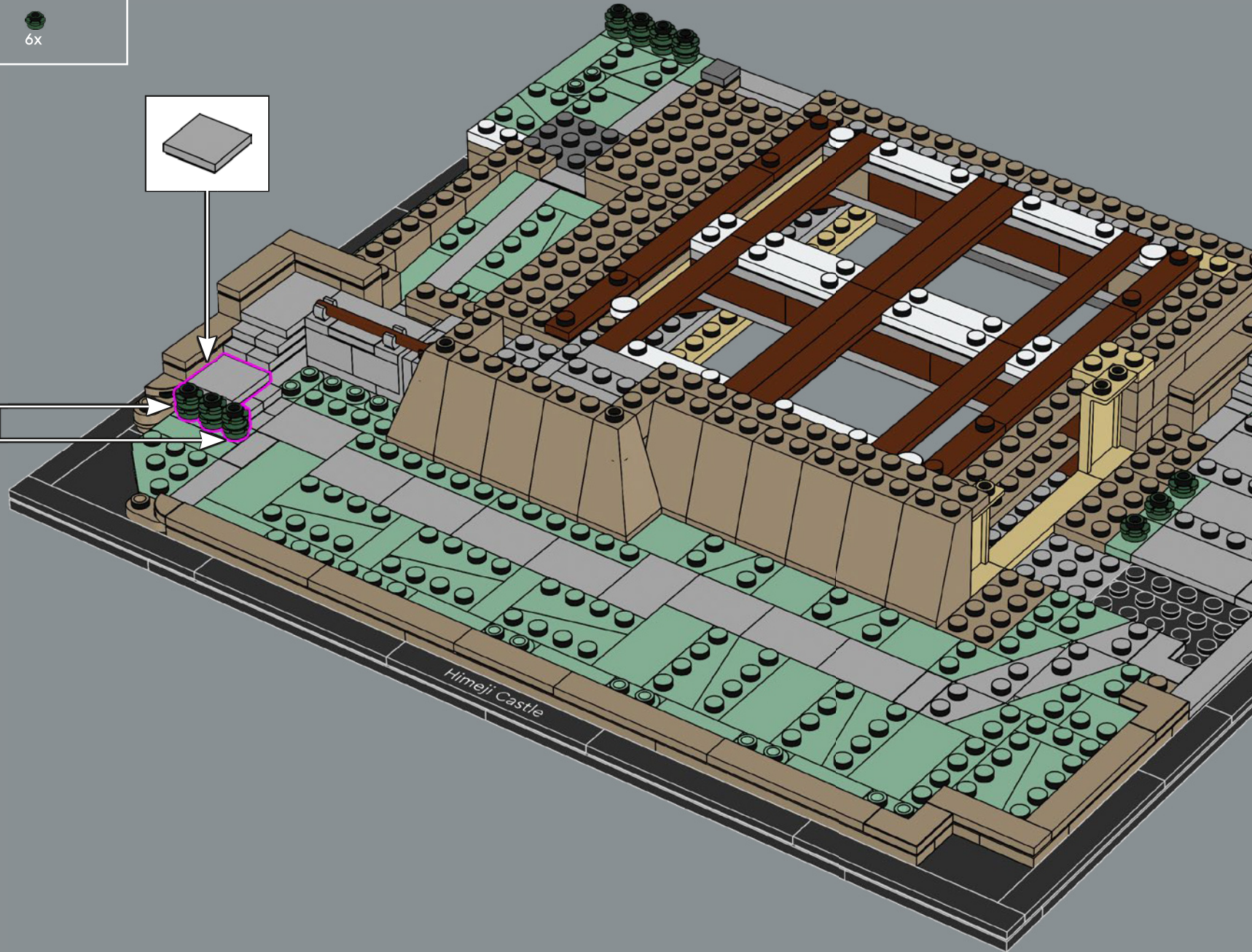
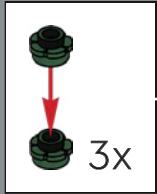

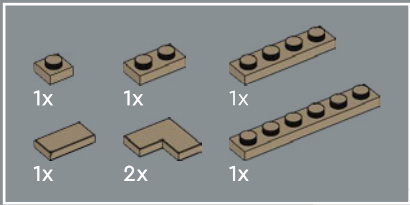

83

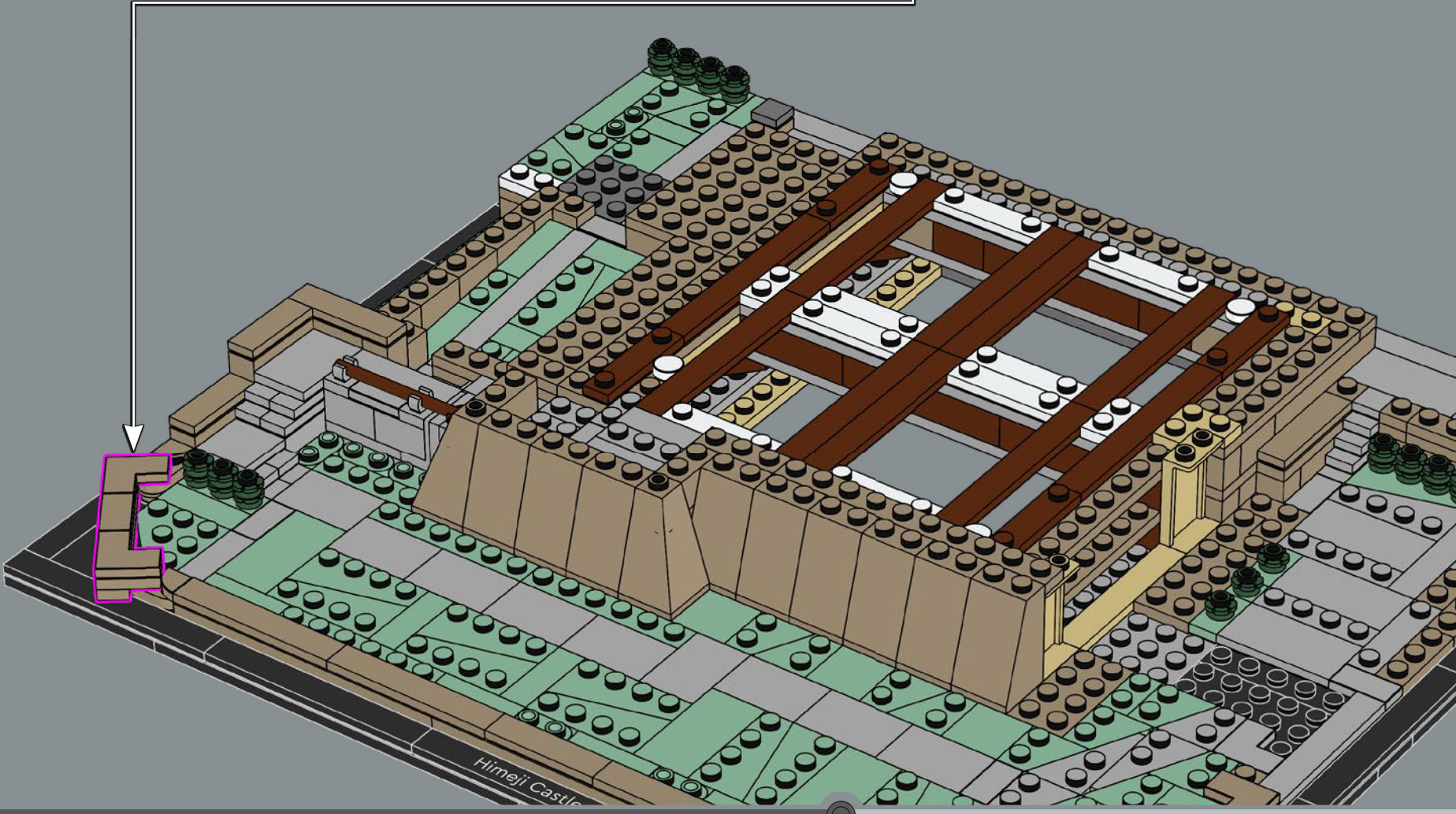
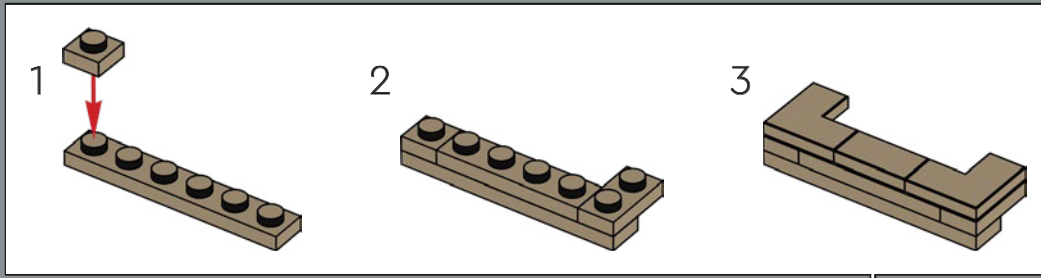

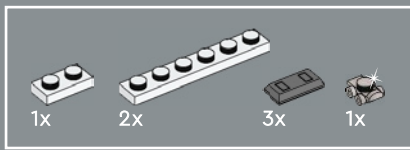

84

1

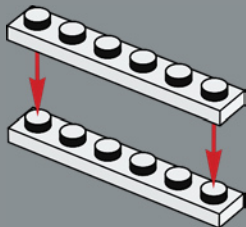

2

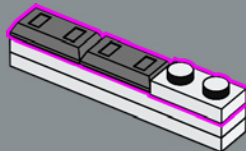

3

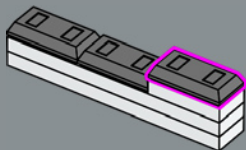

4



1:1

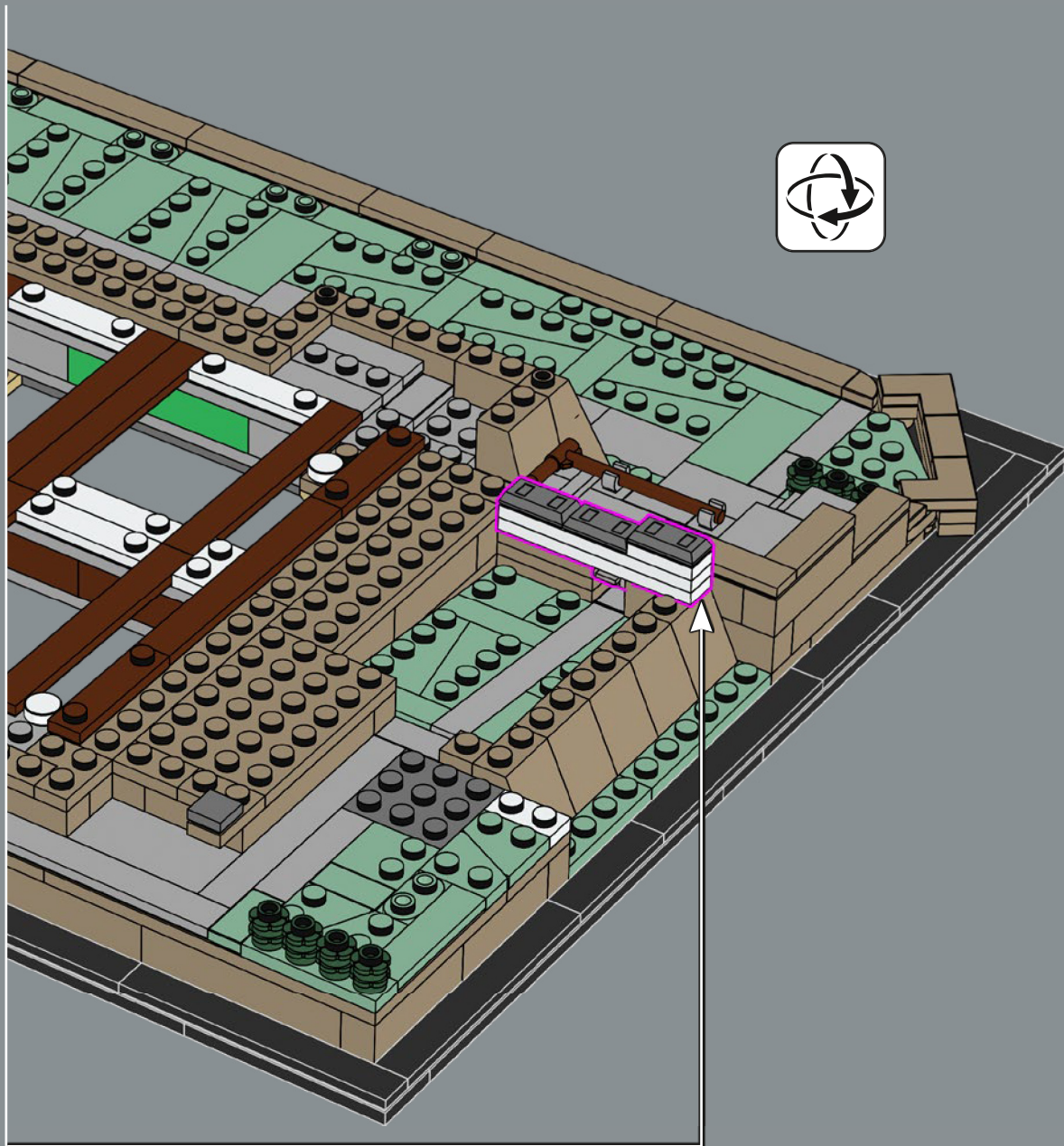

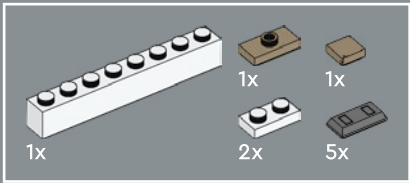

85

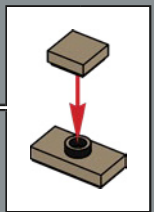
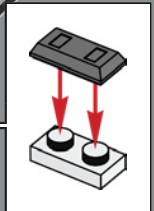
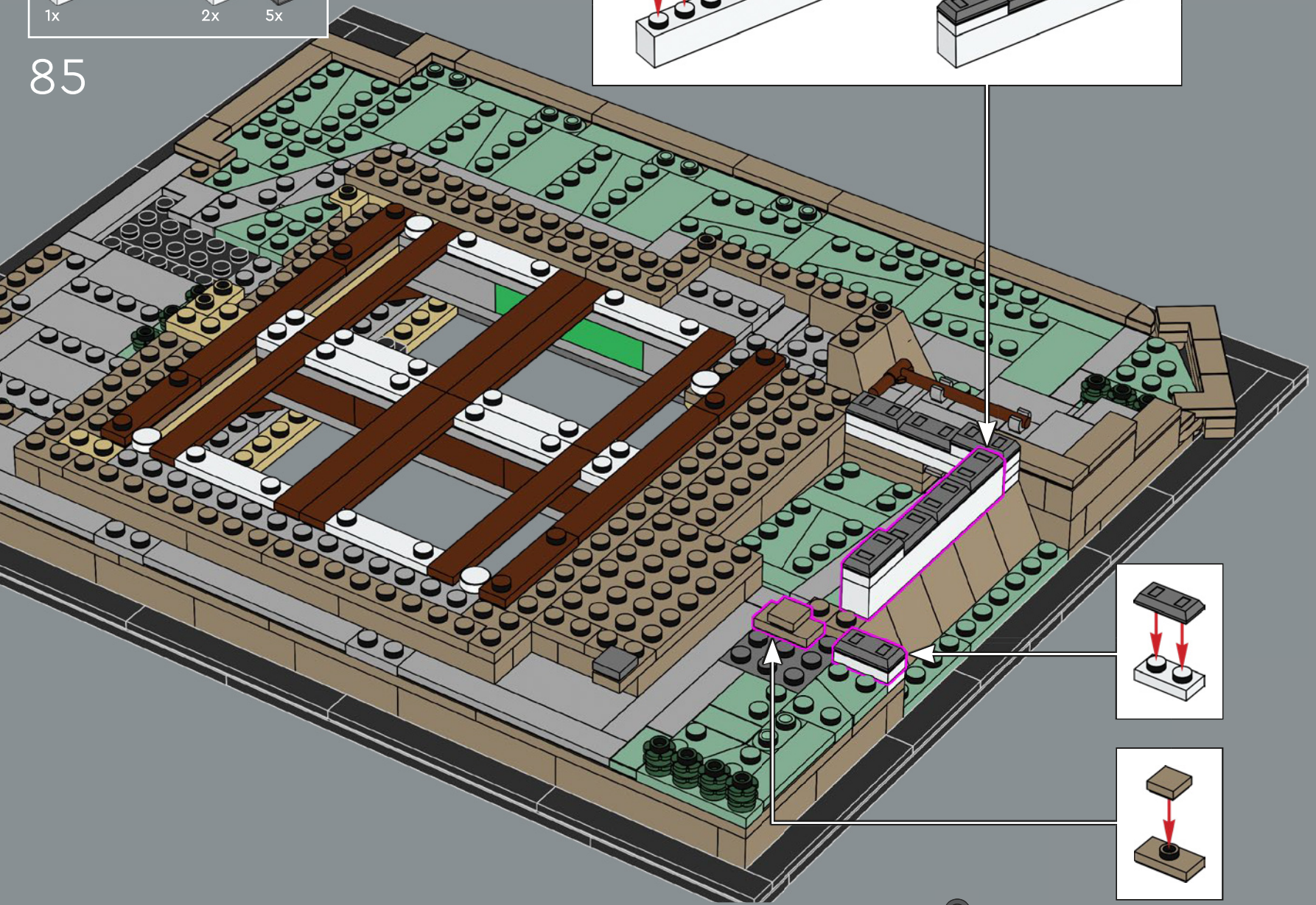
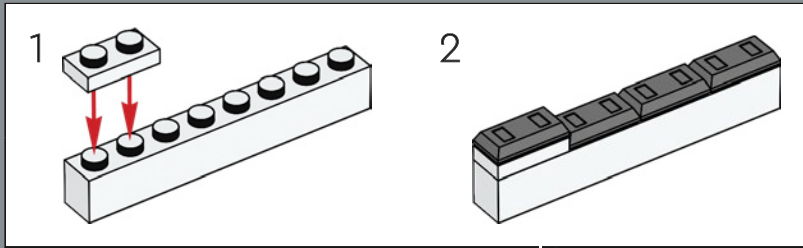

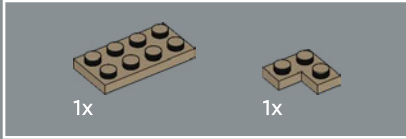
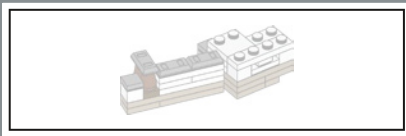

86

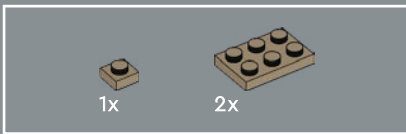
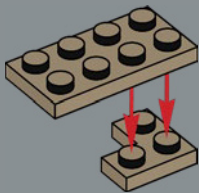

87

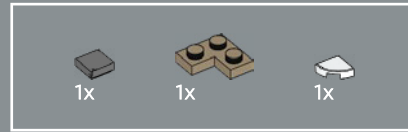
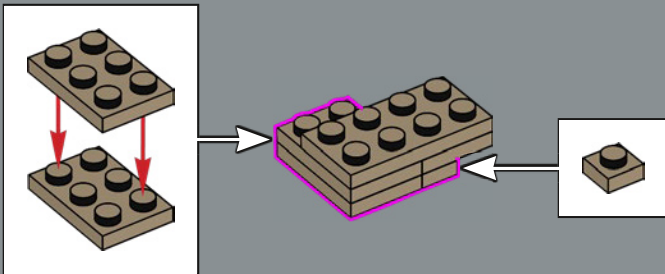

88

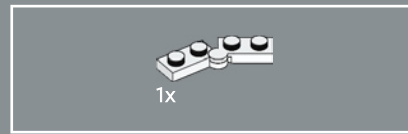
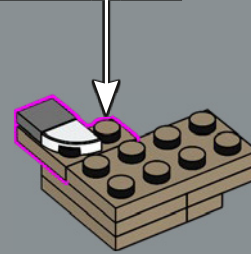
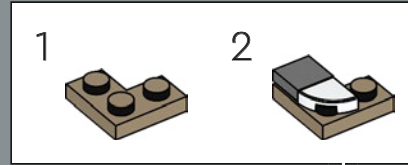

89

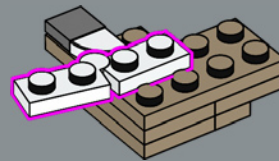

90

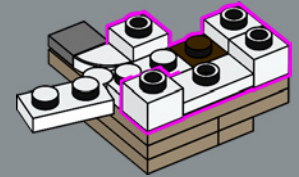

91

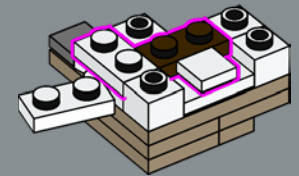

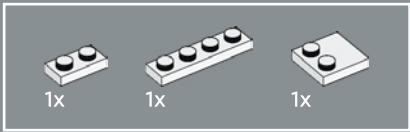

92

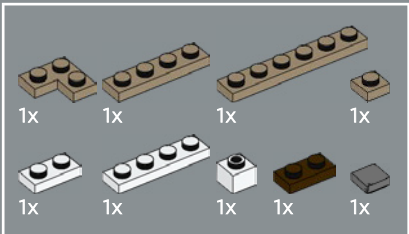
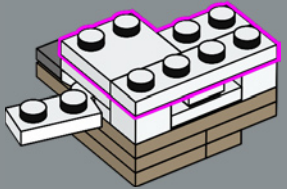

93

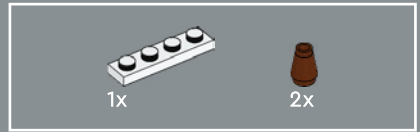
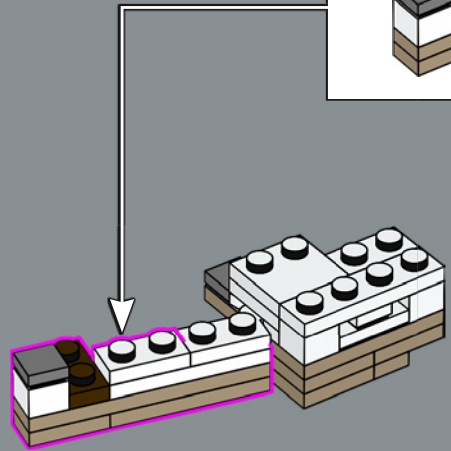
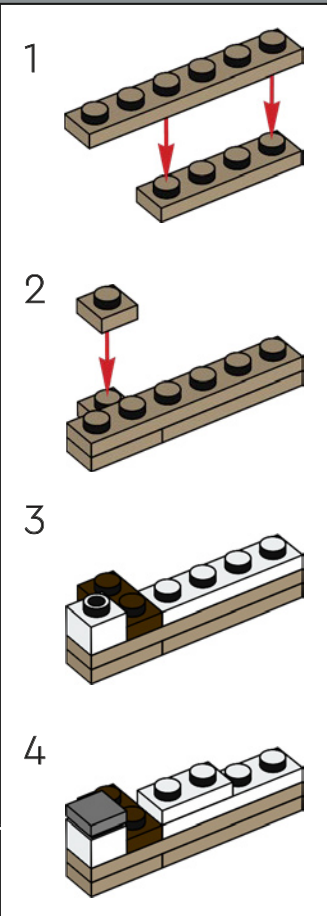

94

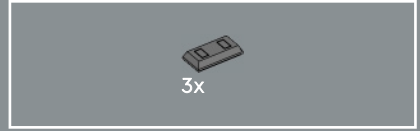
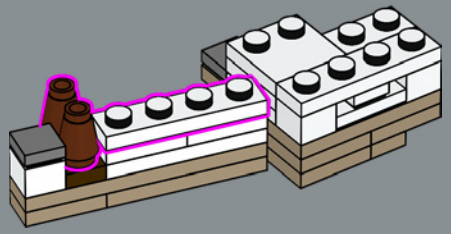

95

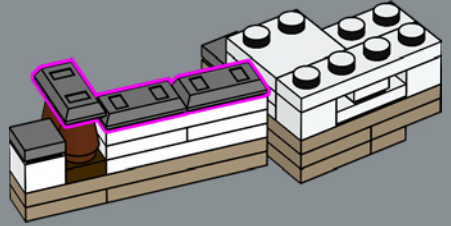

Uno de los rasgos por los que la arquitectura del castillo es tan interesante es que muchos de los muros, torres y caminos están colocados en ángulos irregulares.

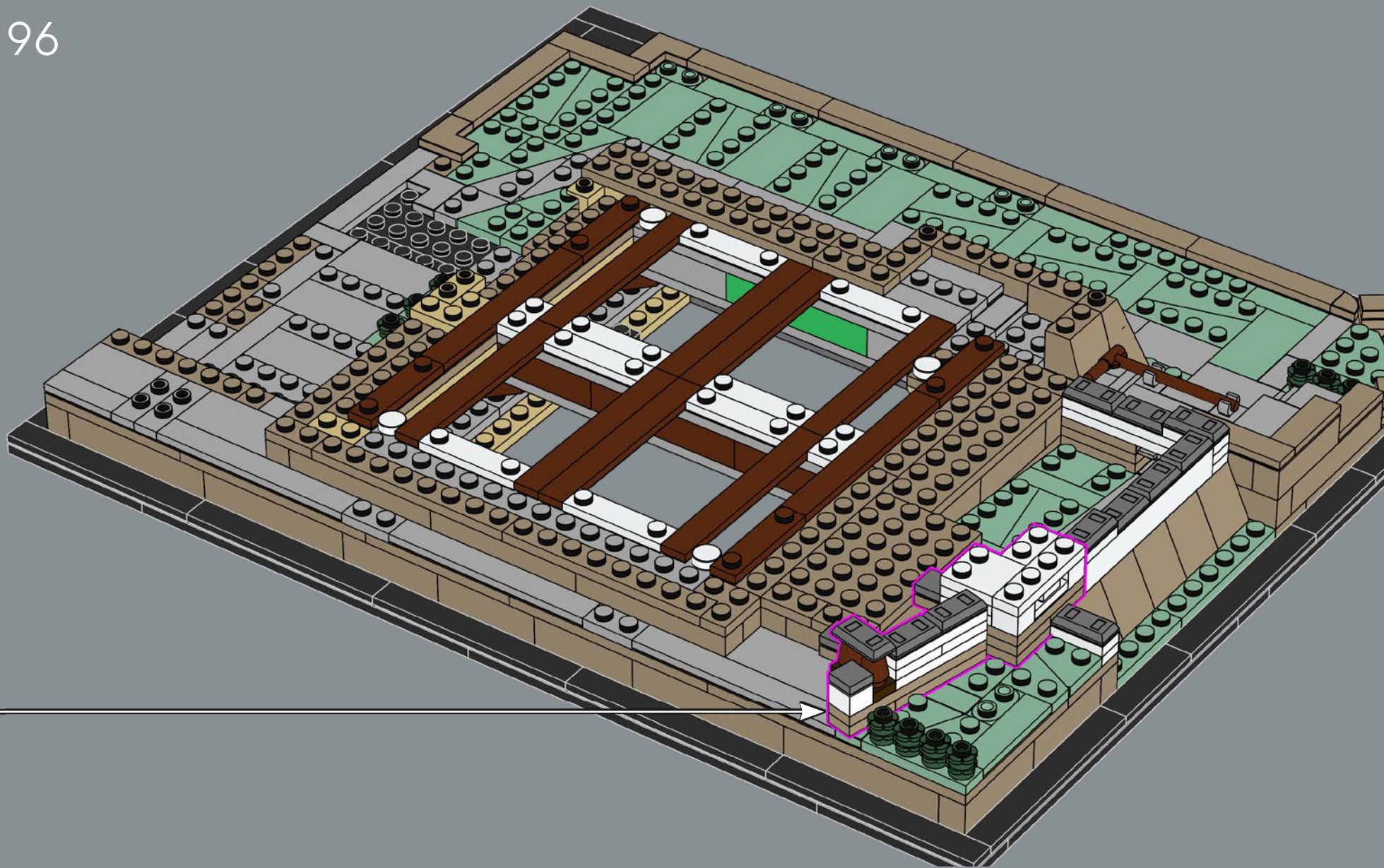

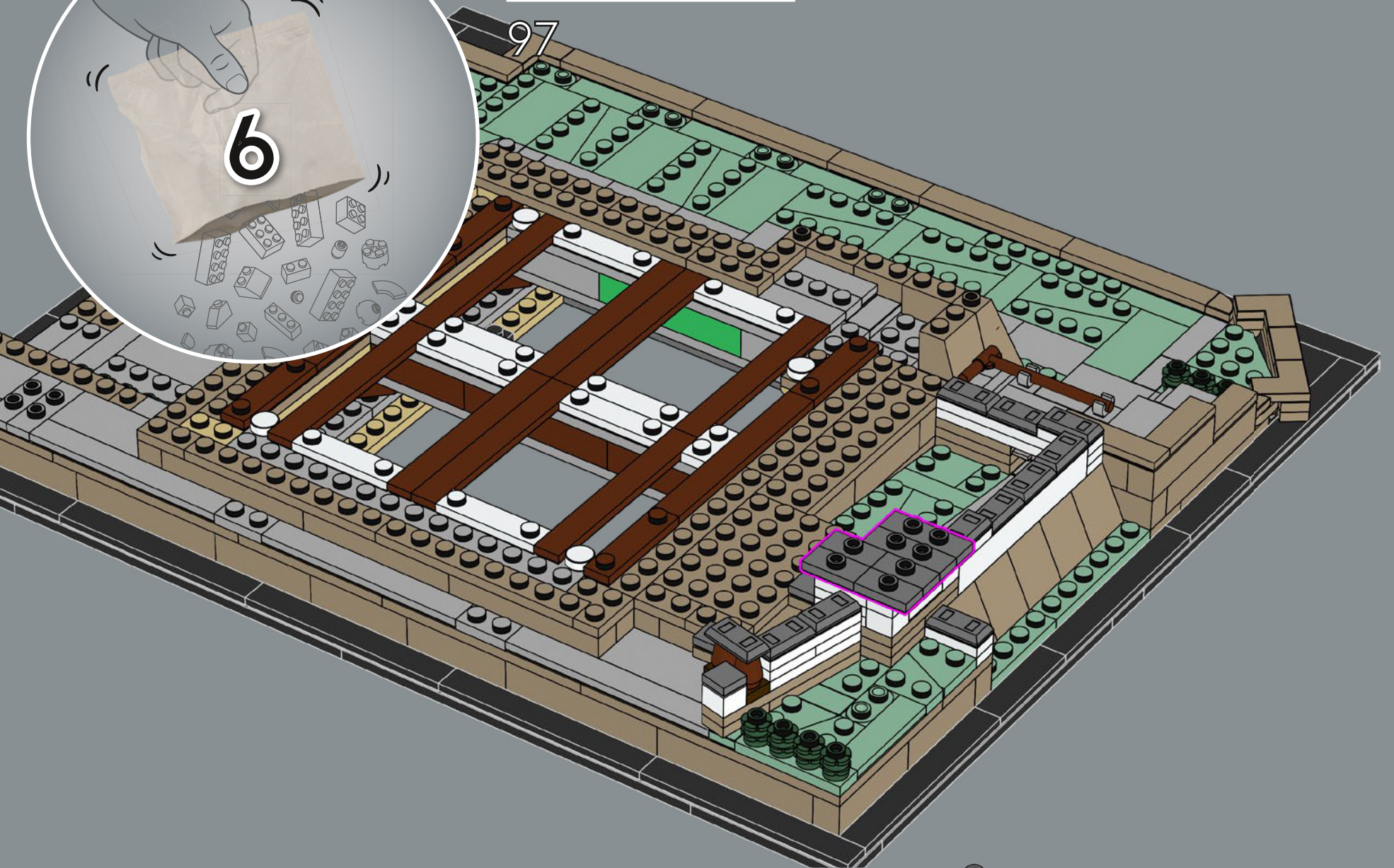
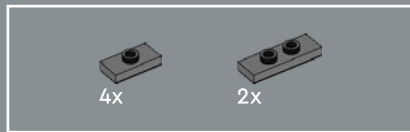

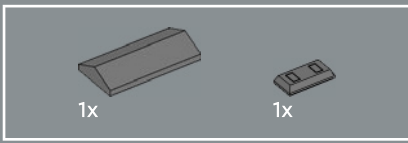

98

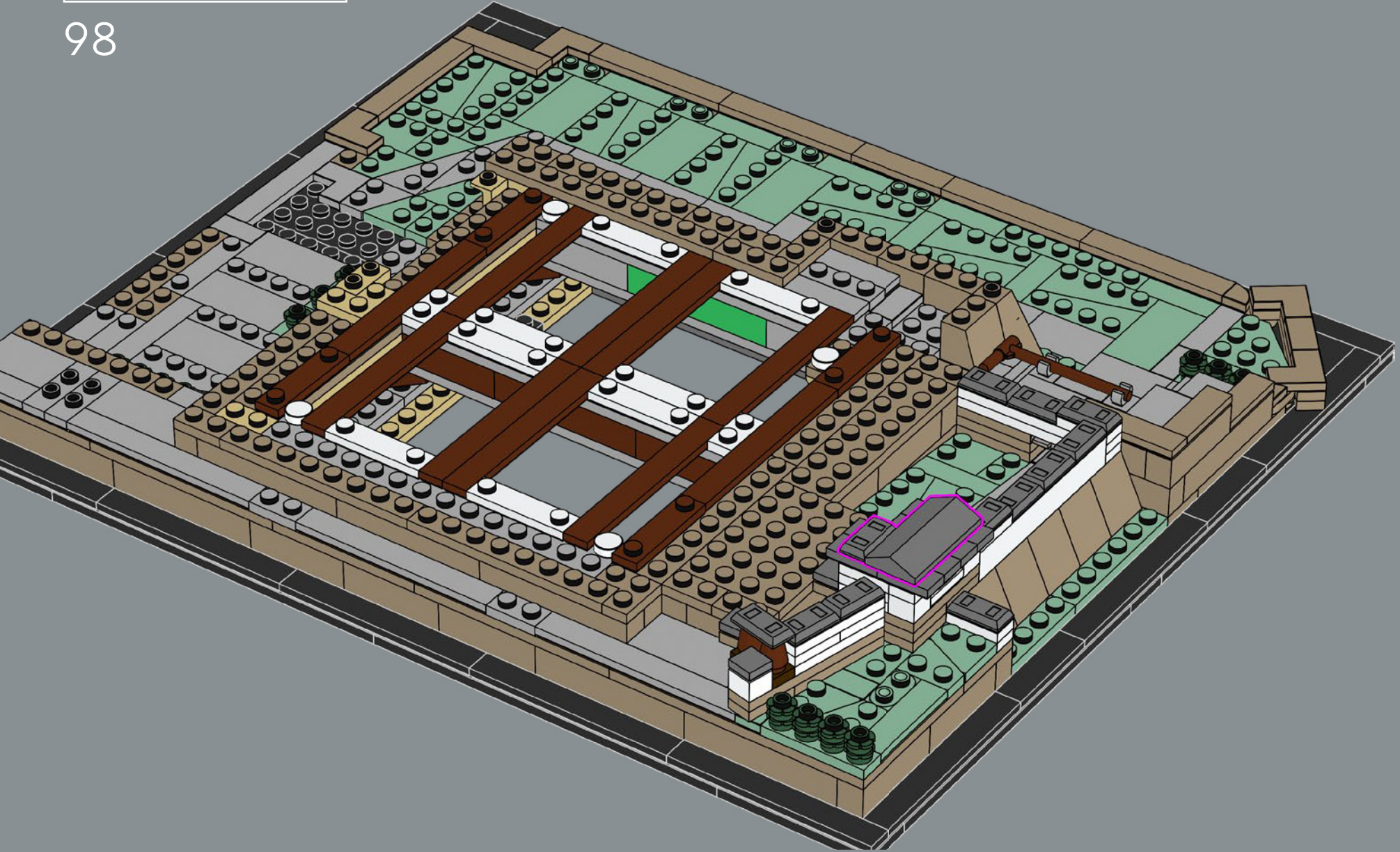

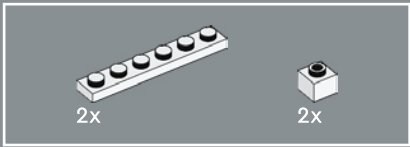

99

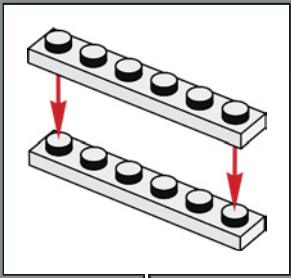

Himeji Castle



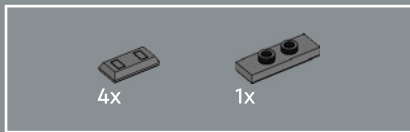

100

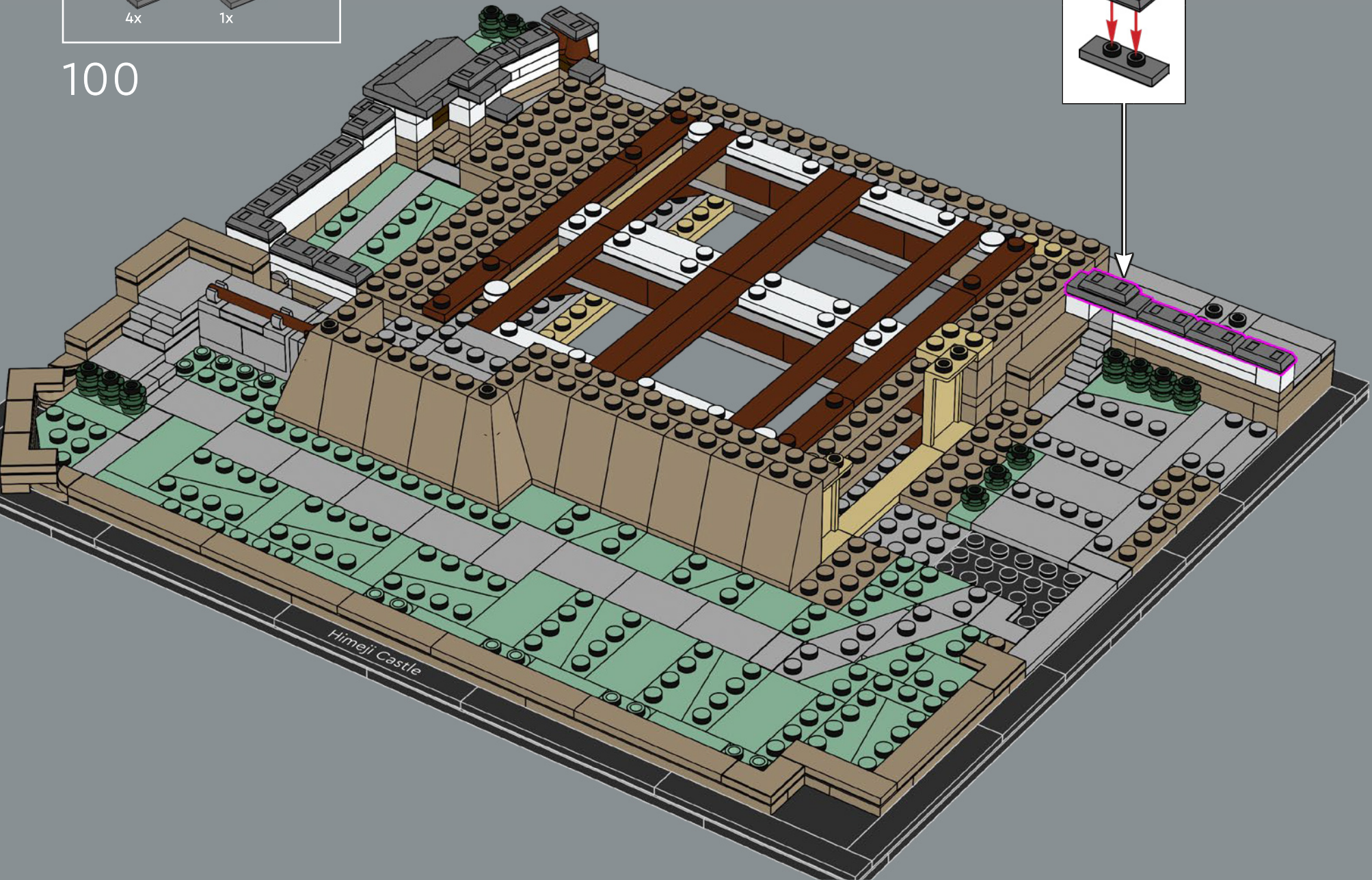
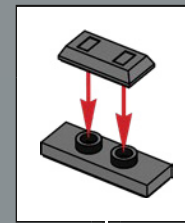

Himeji Castle

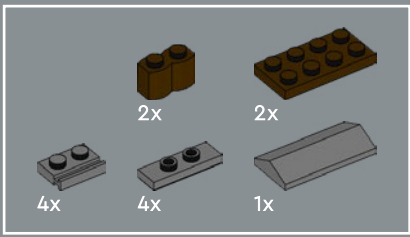

101

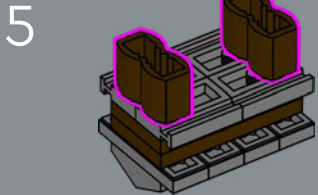
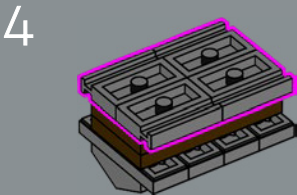
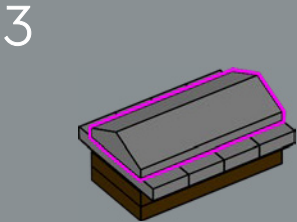
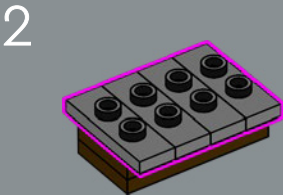
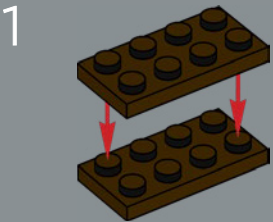

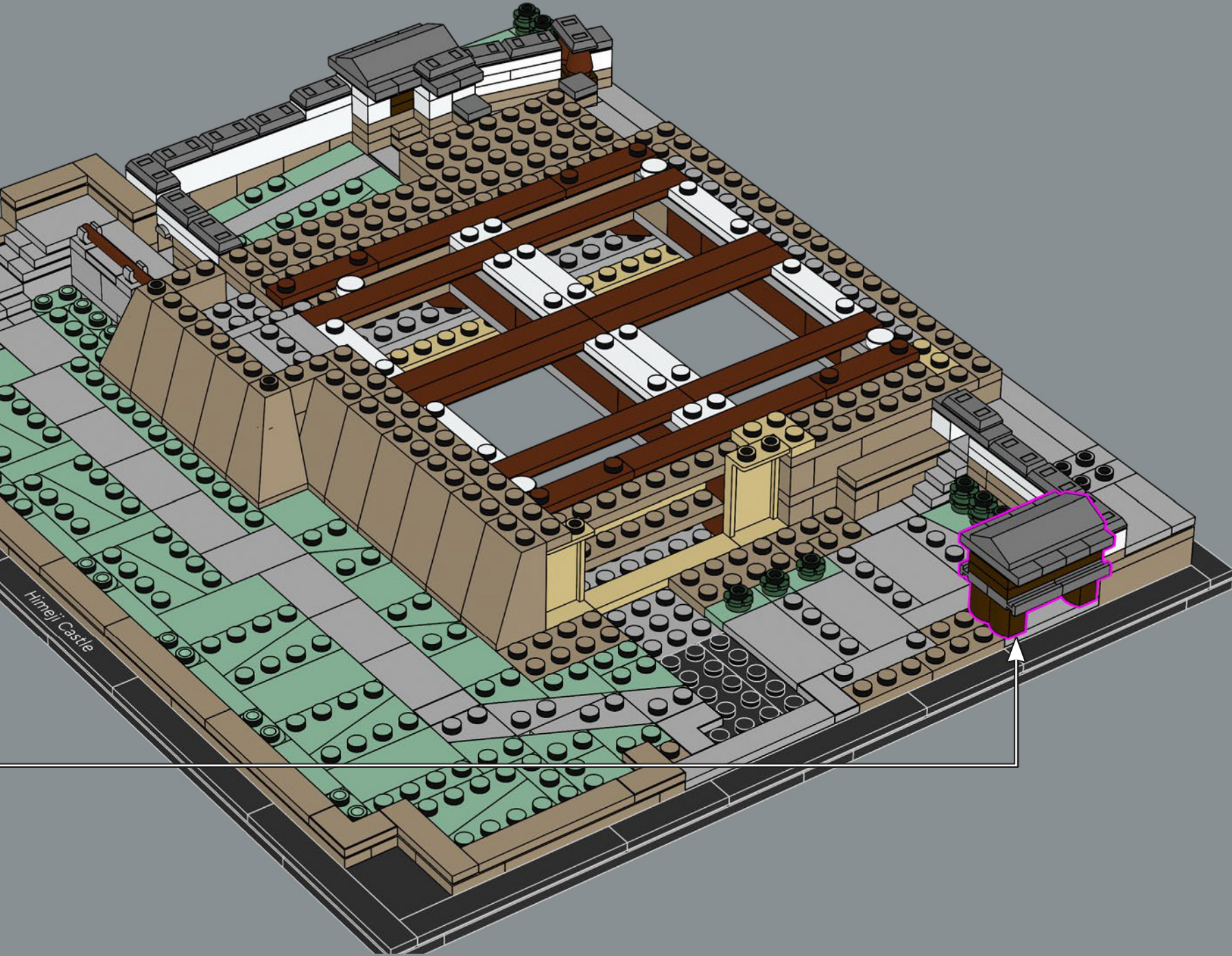

Himeji Castle

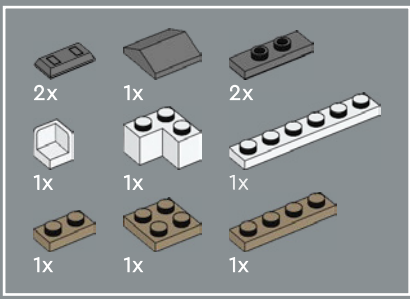

102

1

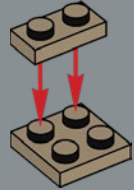

2

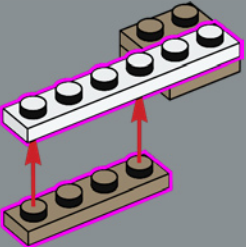

3

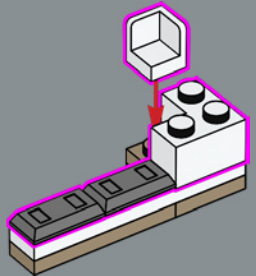

4

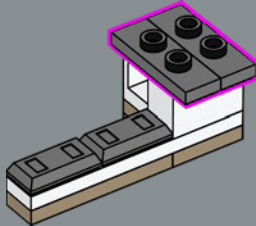

5

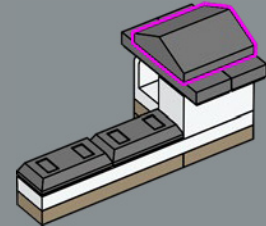

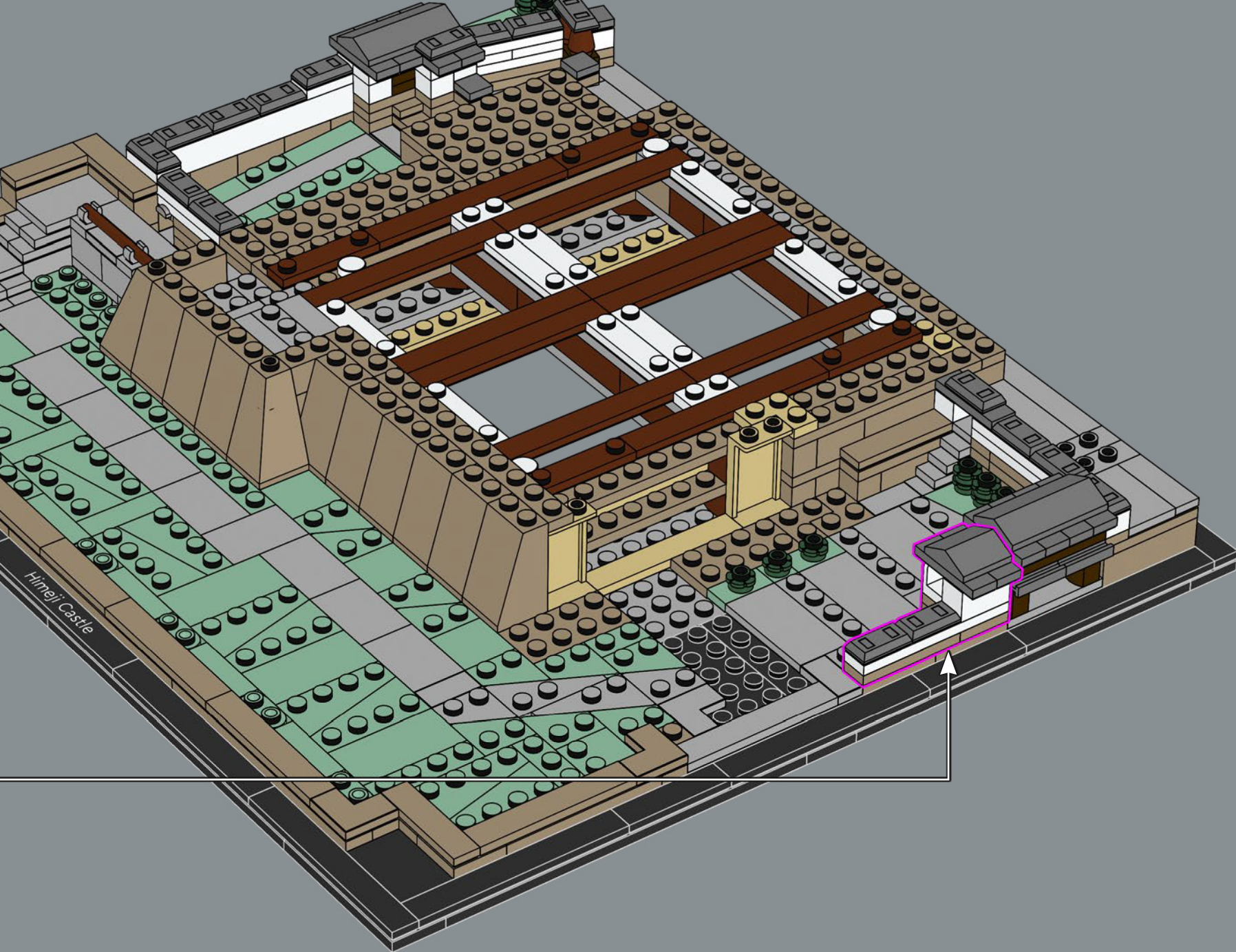

1x 2x 1x

103

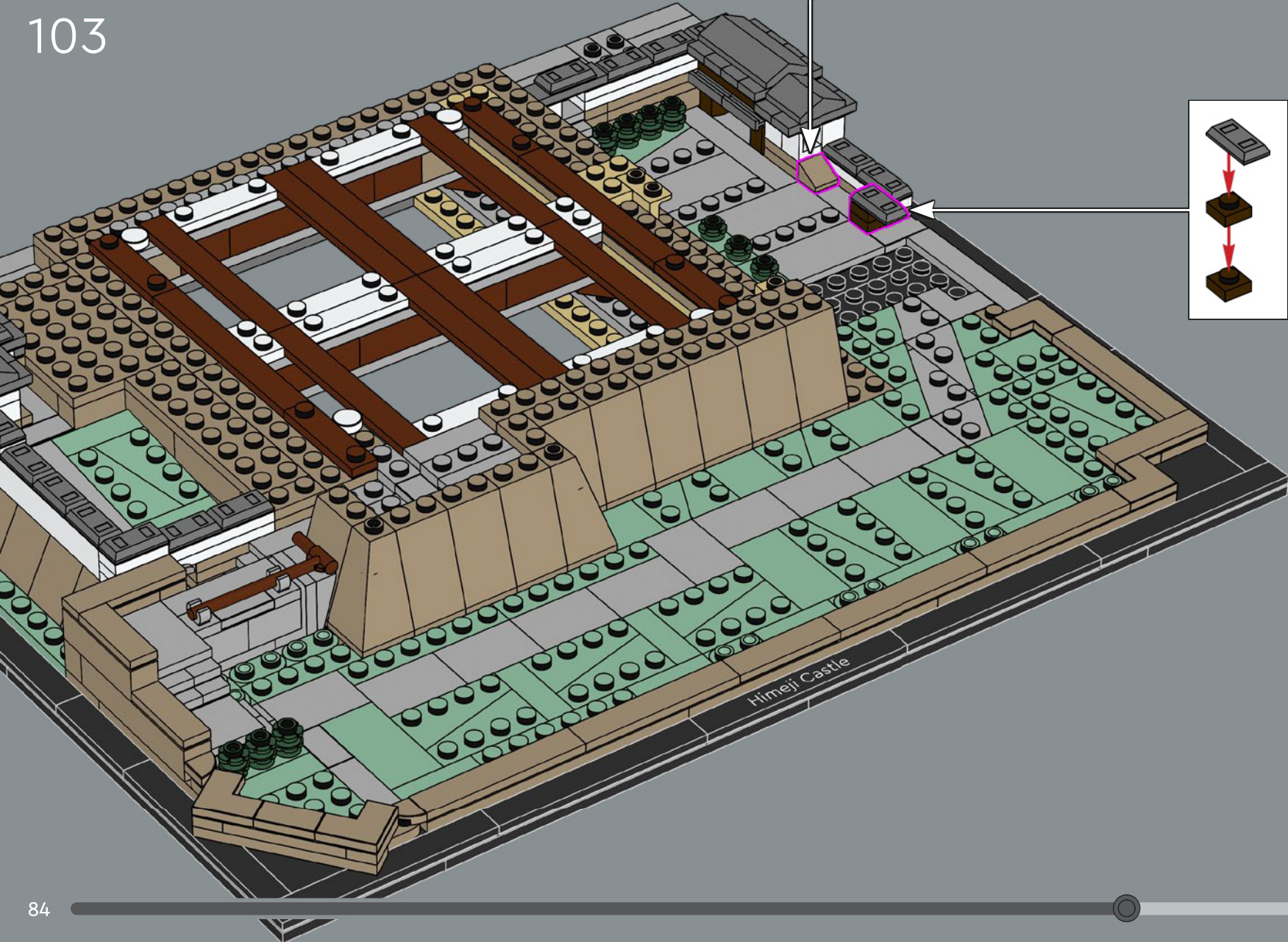
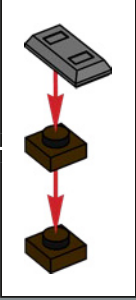

Himeji Castle



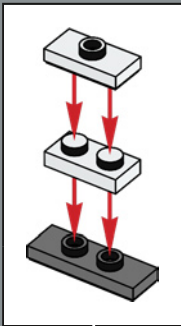
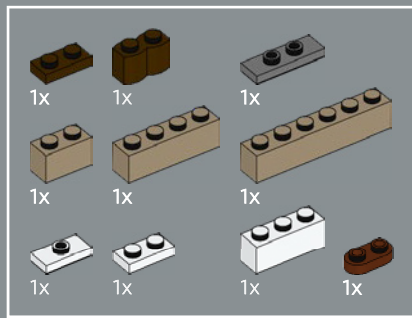

104

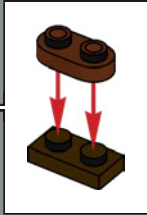
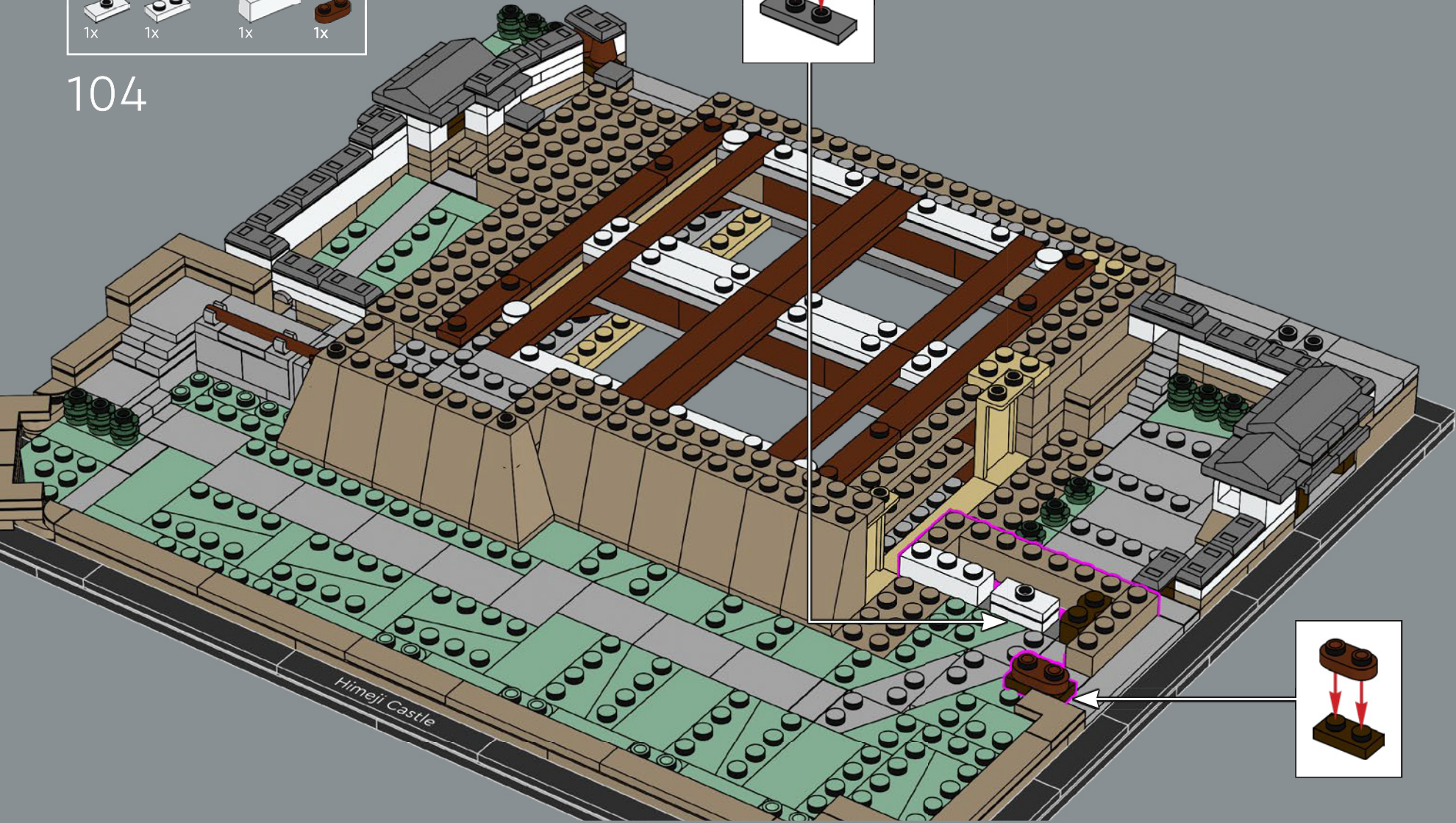

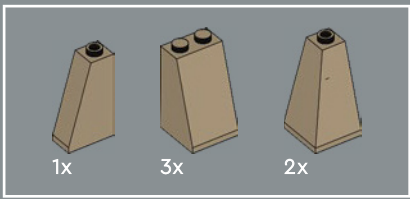

105

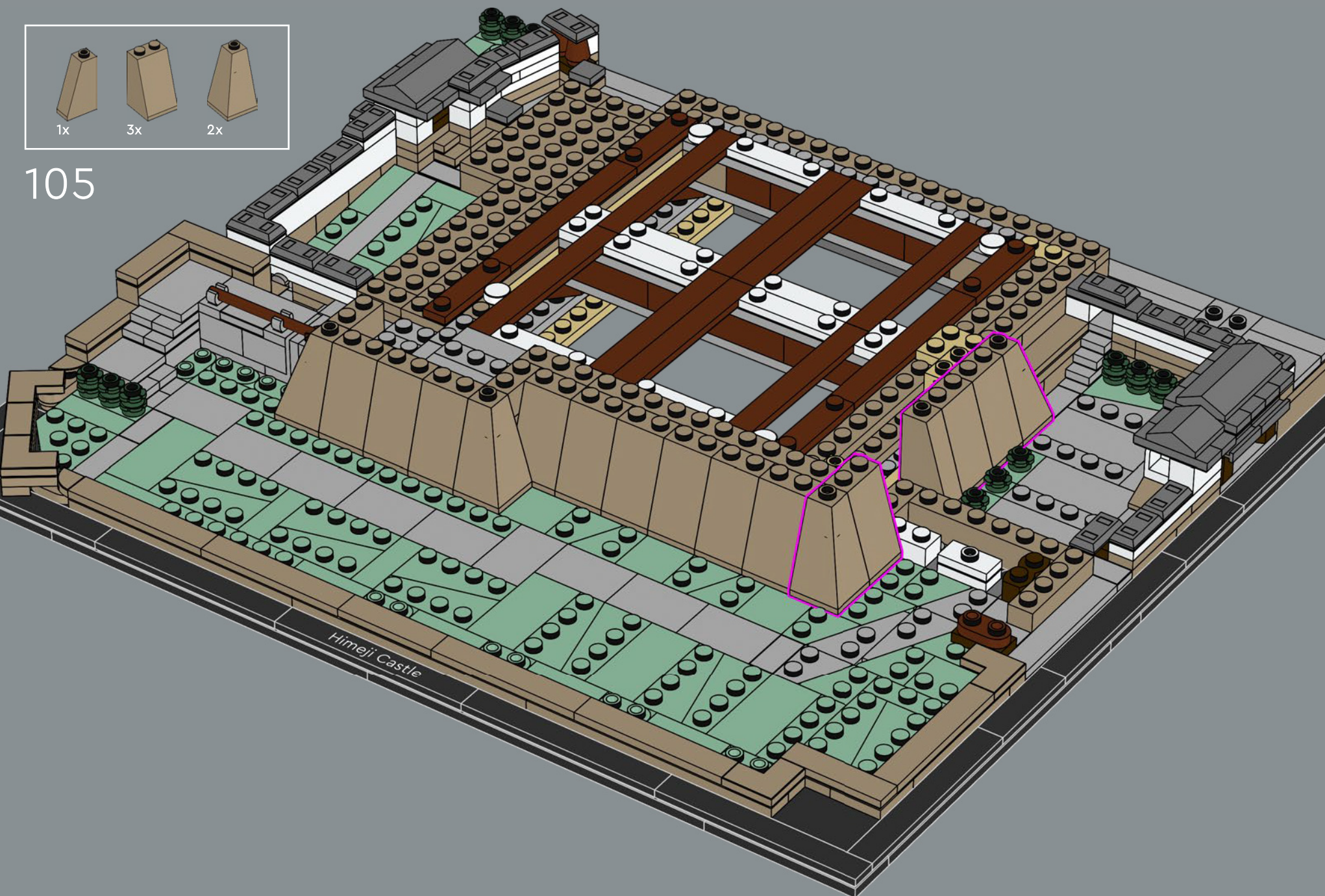

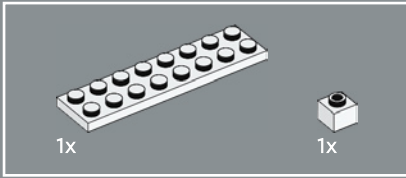
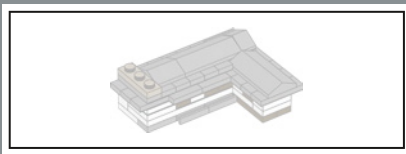

106

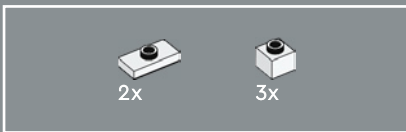
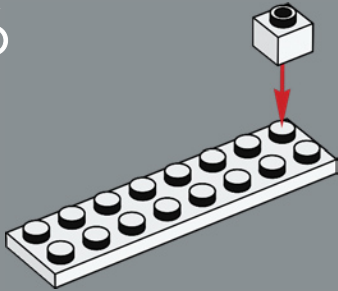

107

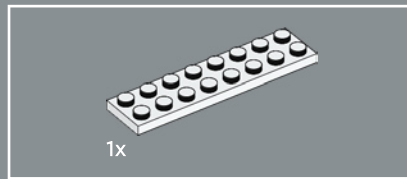
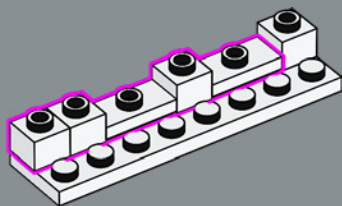

108

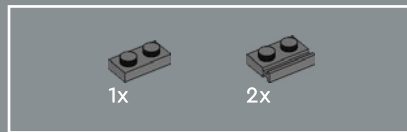
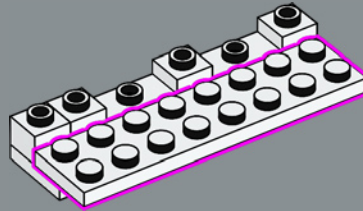

109

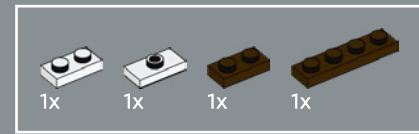
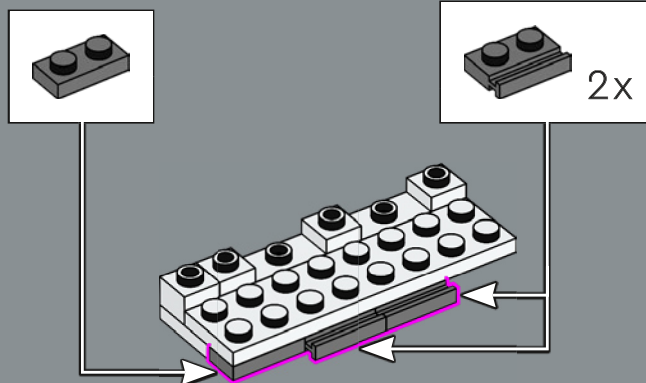

110

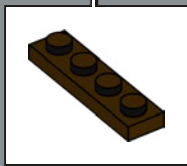
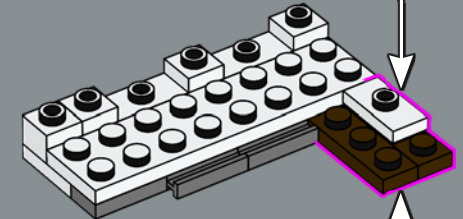
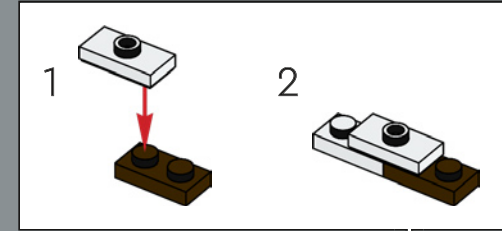

111

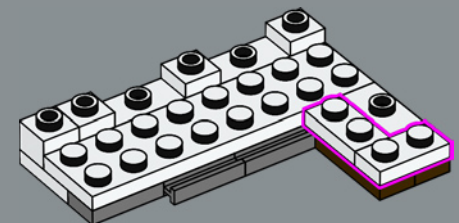

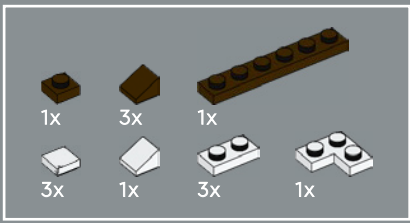

112

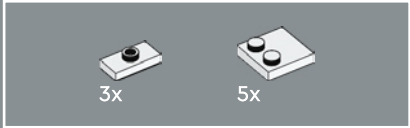
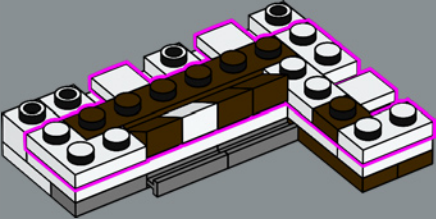

113

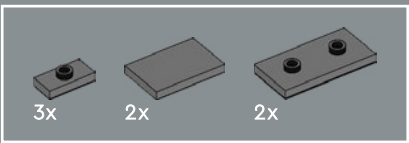
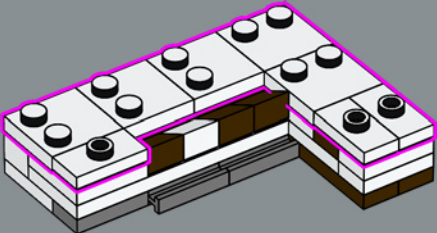

114

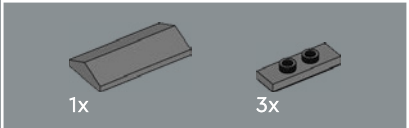
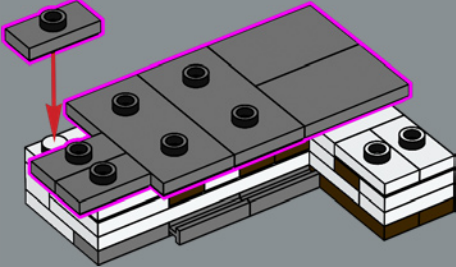

115

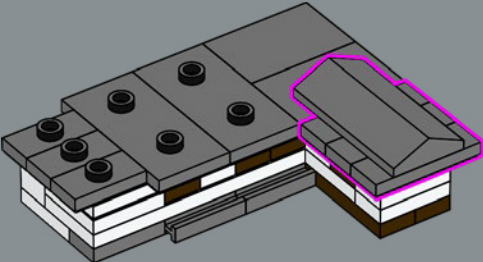
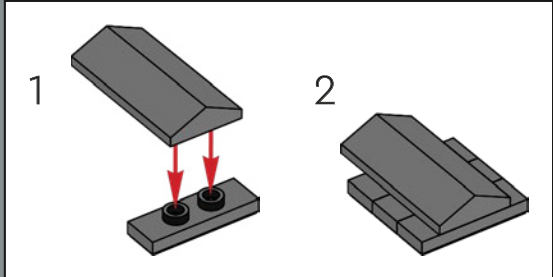

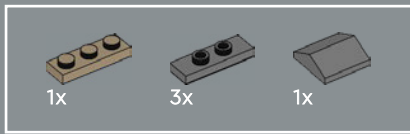

116

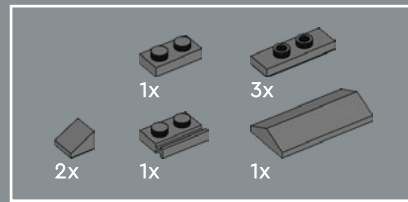
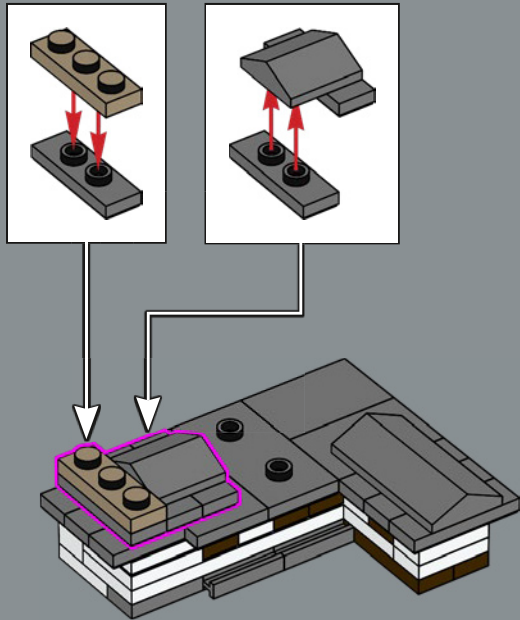

117

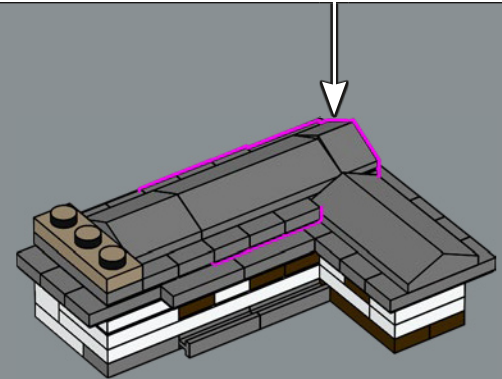
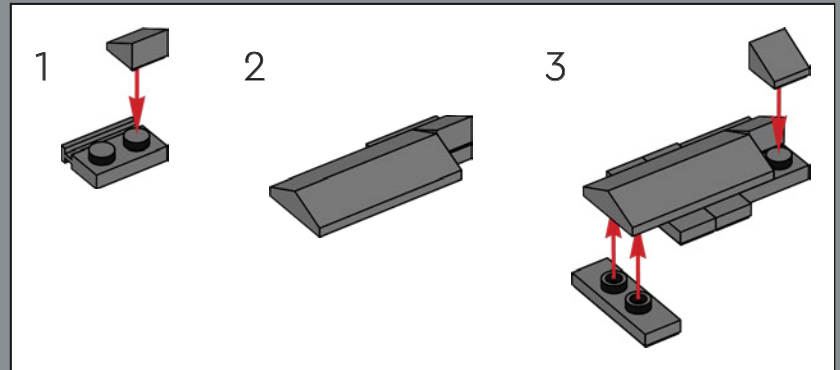

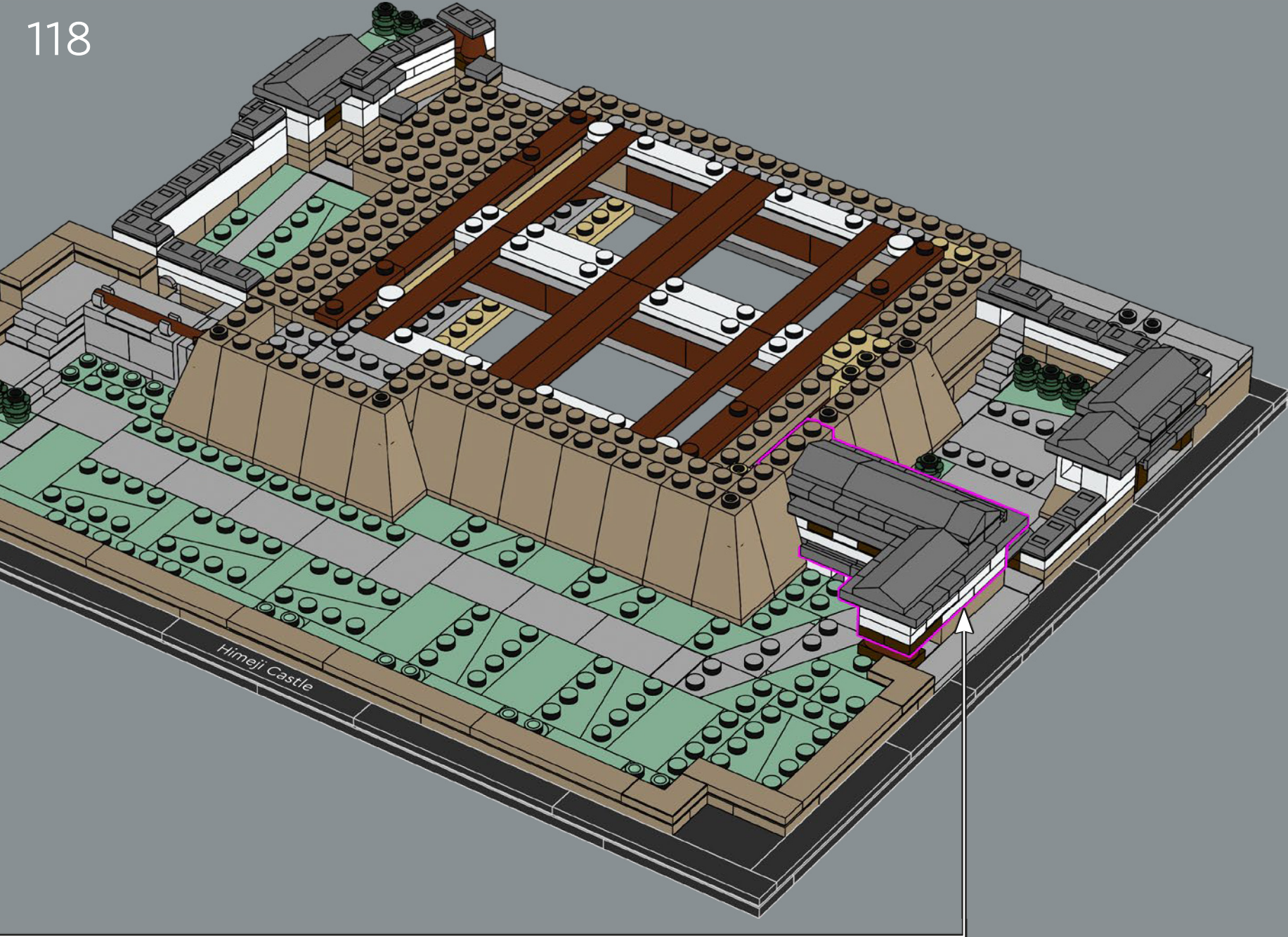

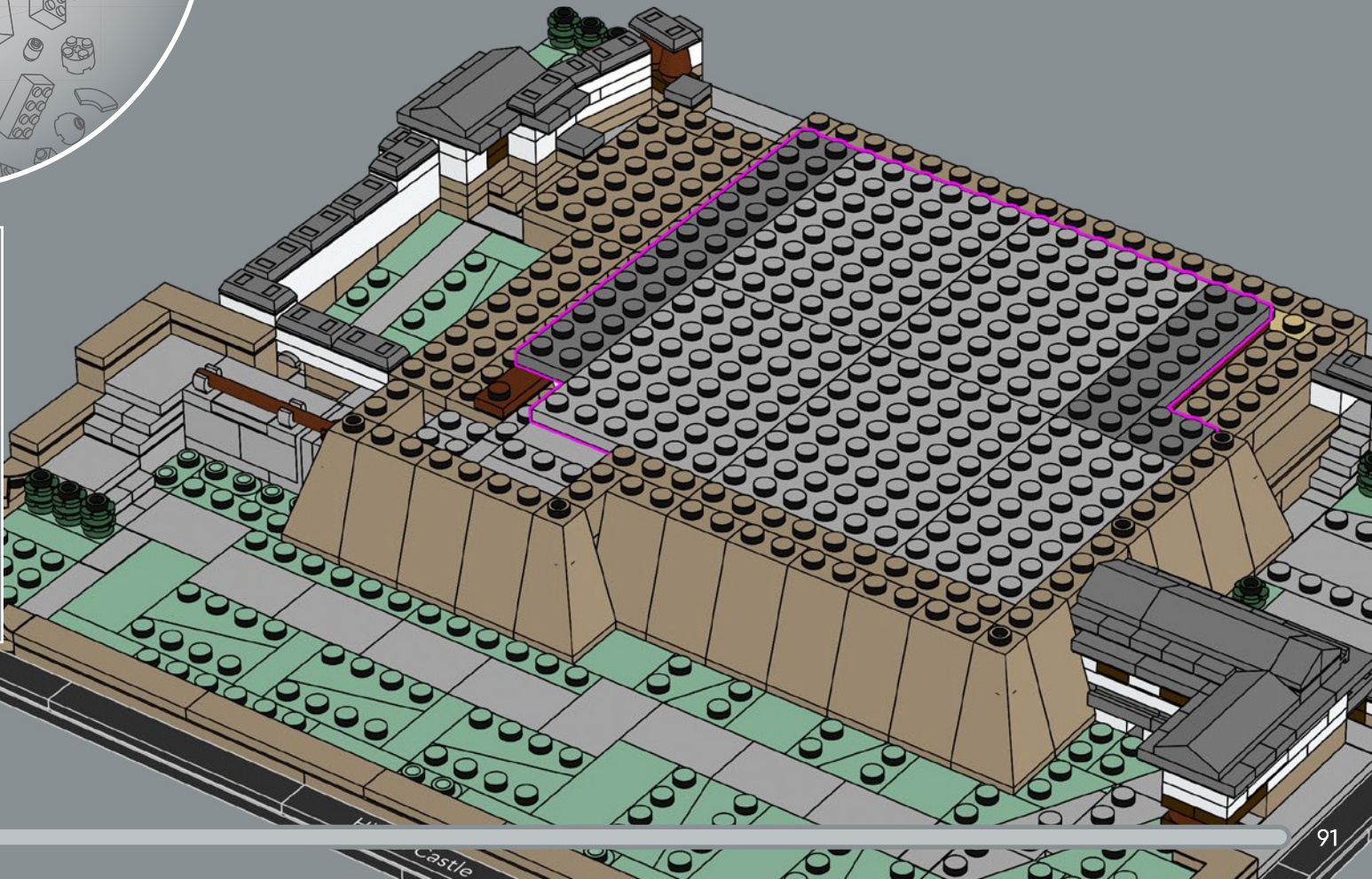
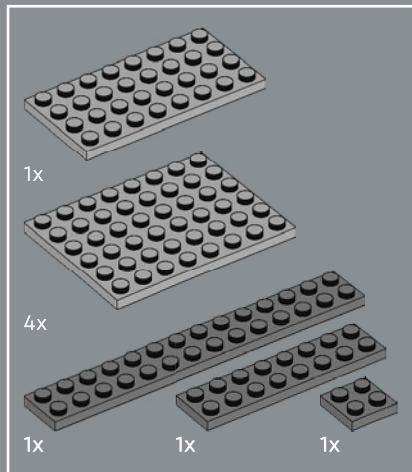

119

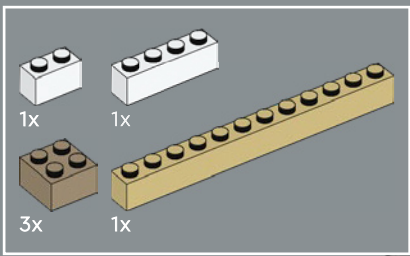

120

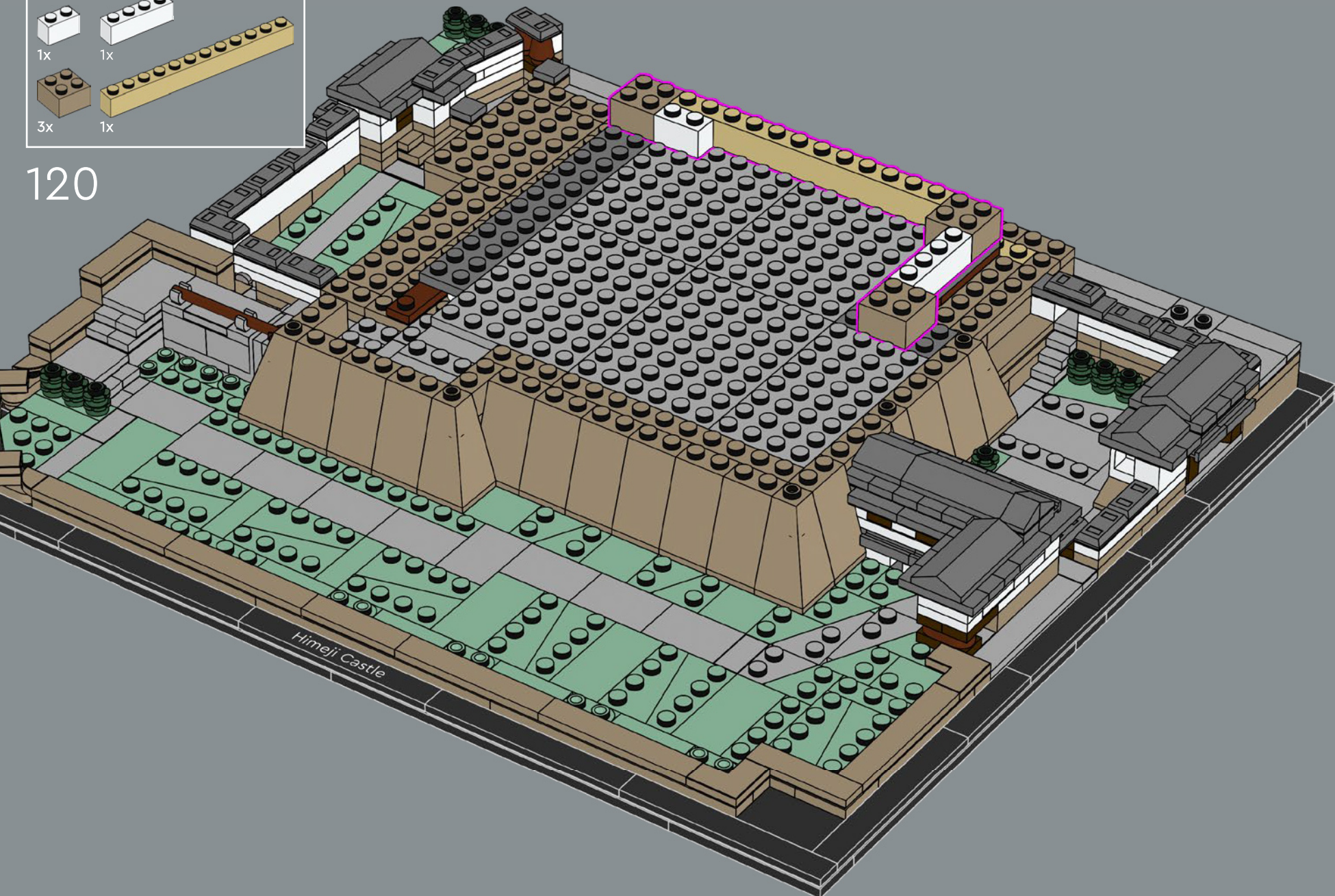

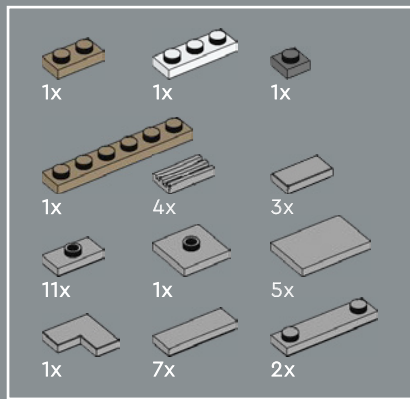

121

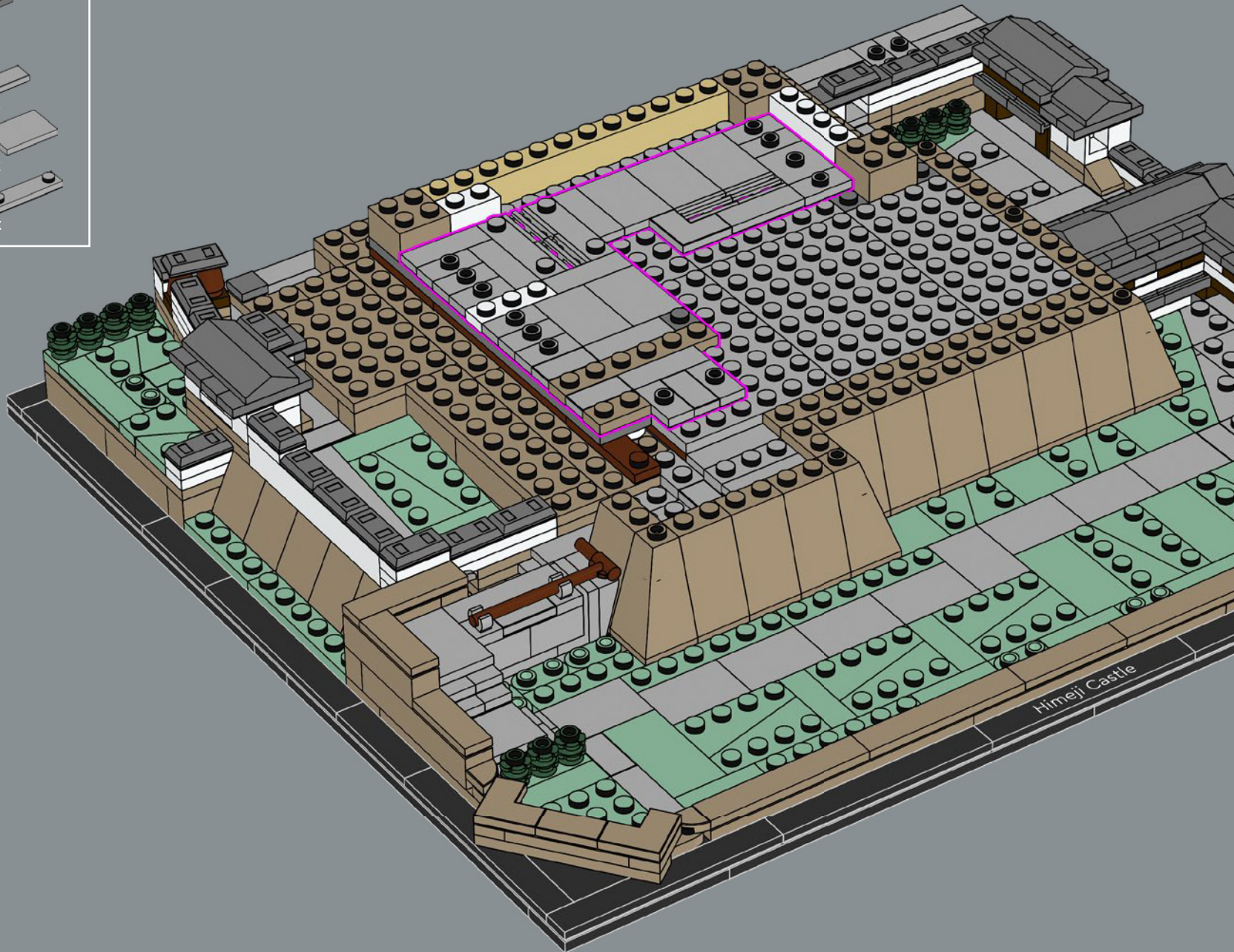

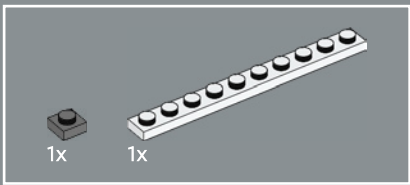

122

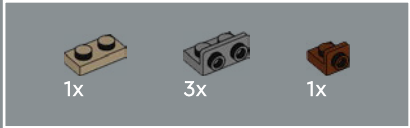
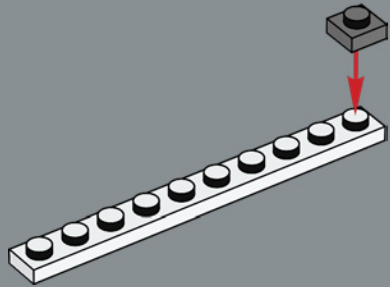

123

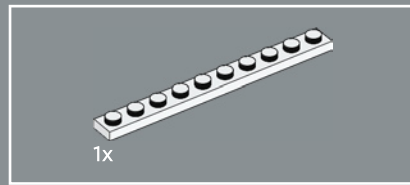
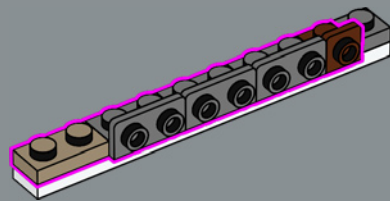

124

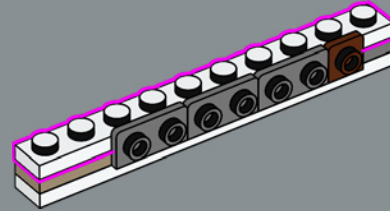

125

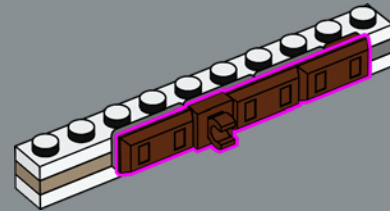

126

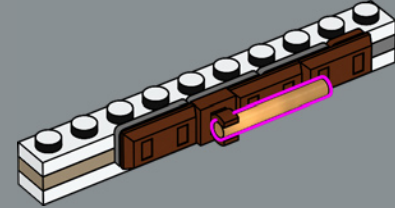

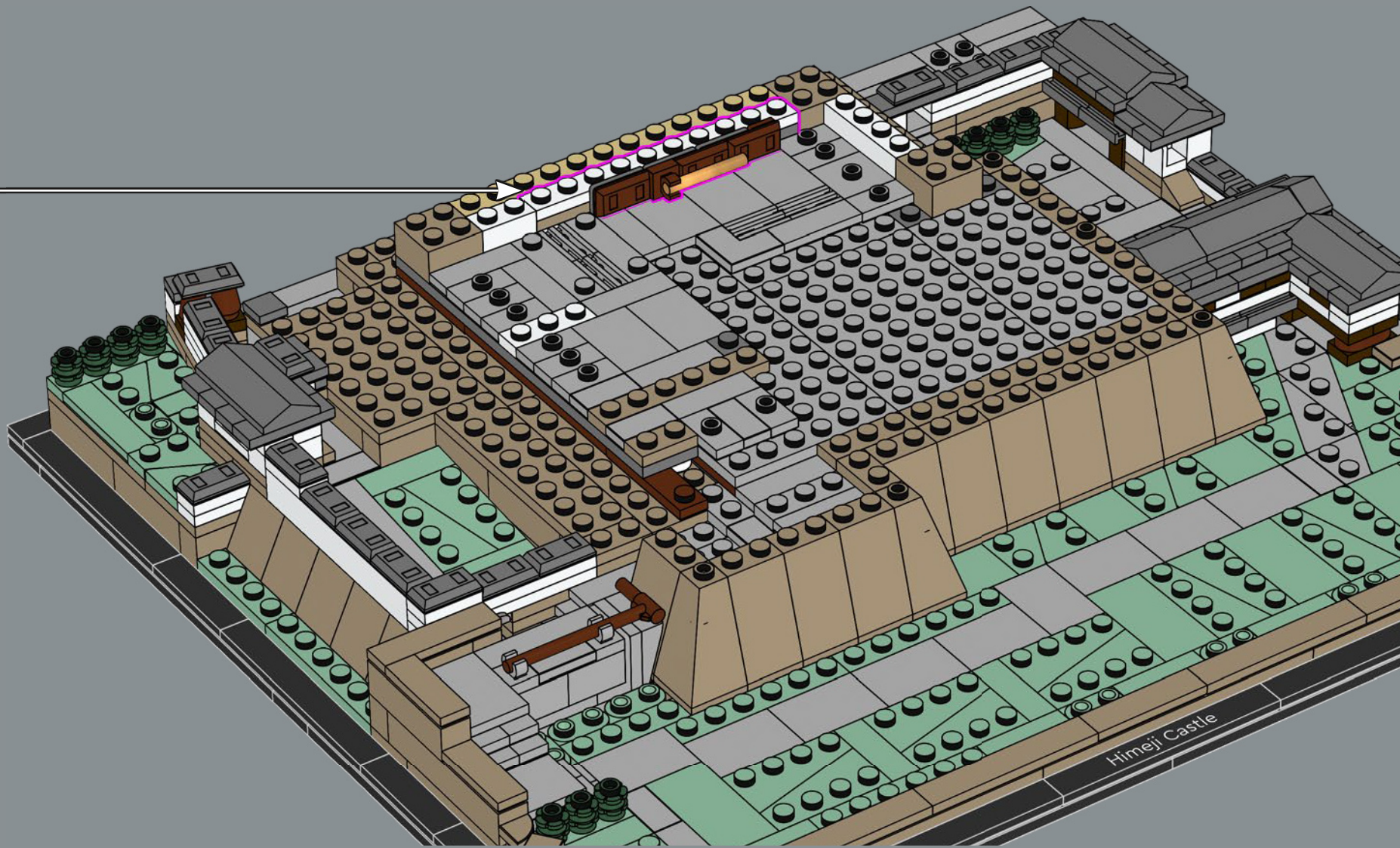

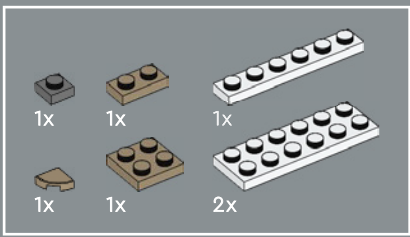

128

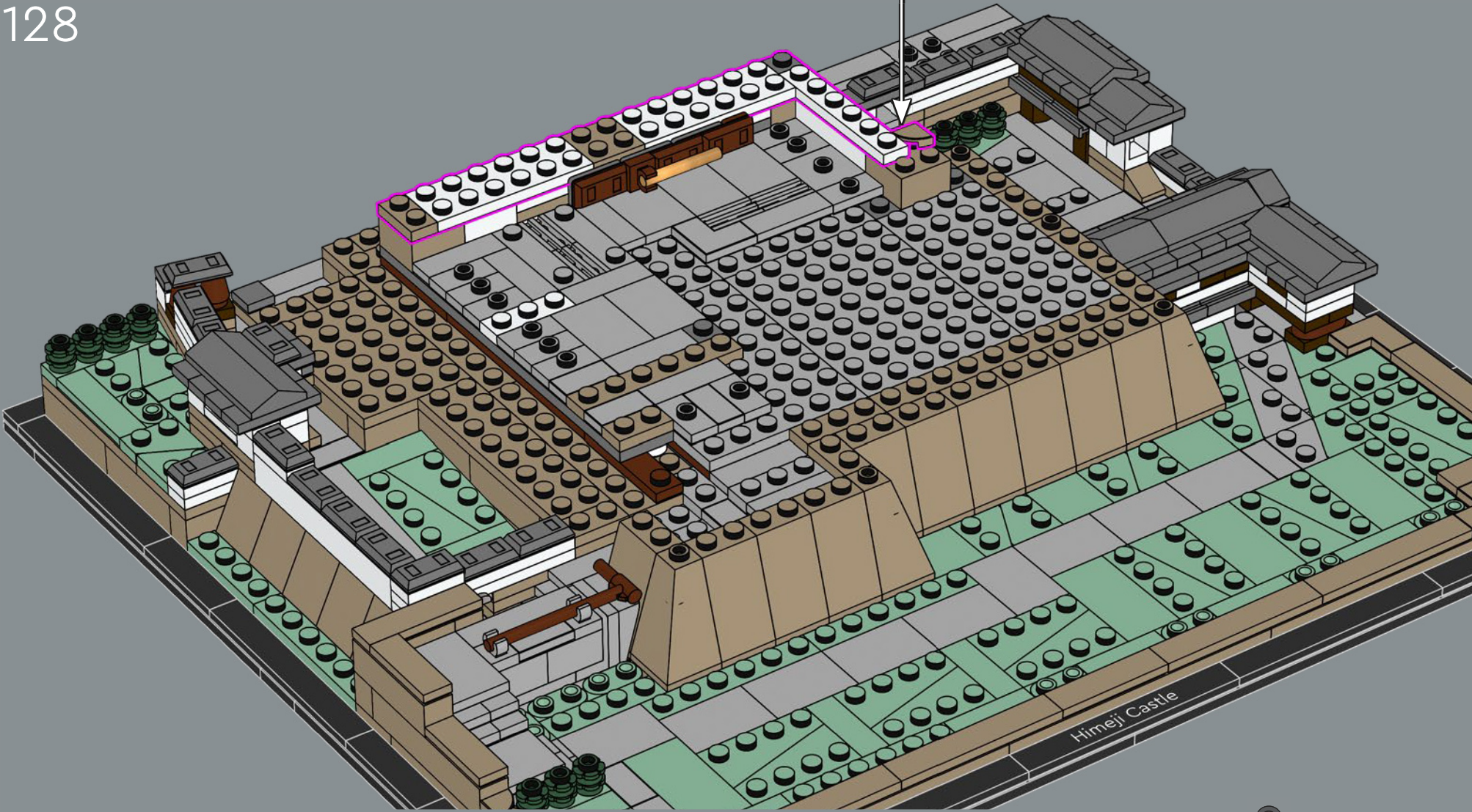

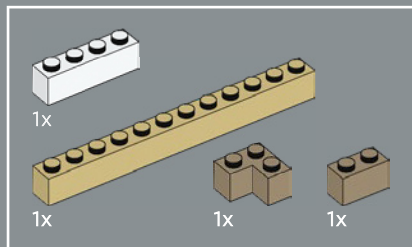

129

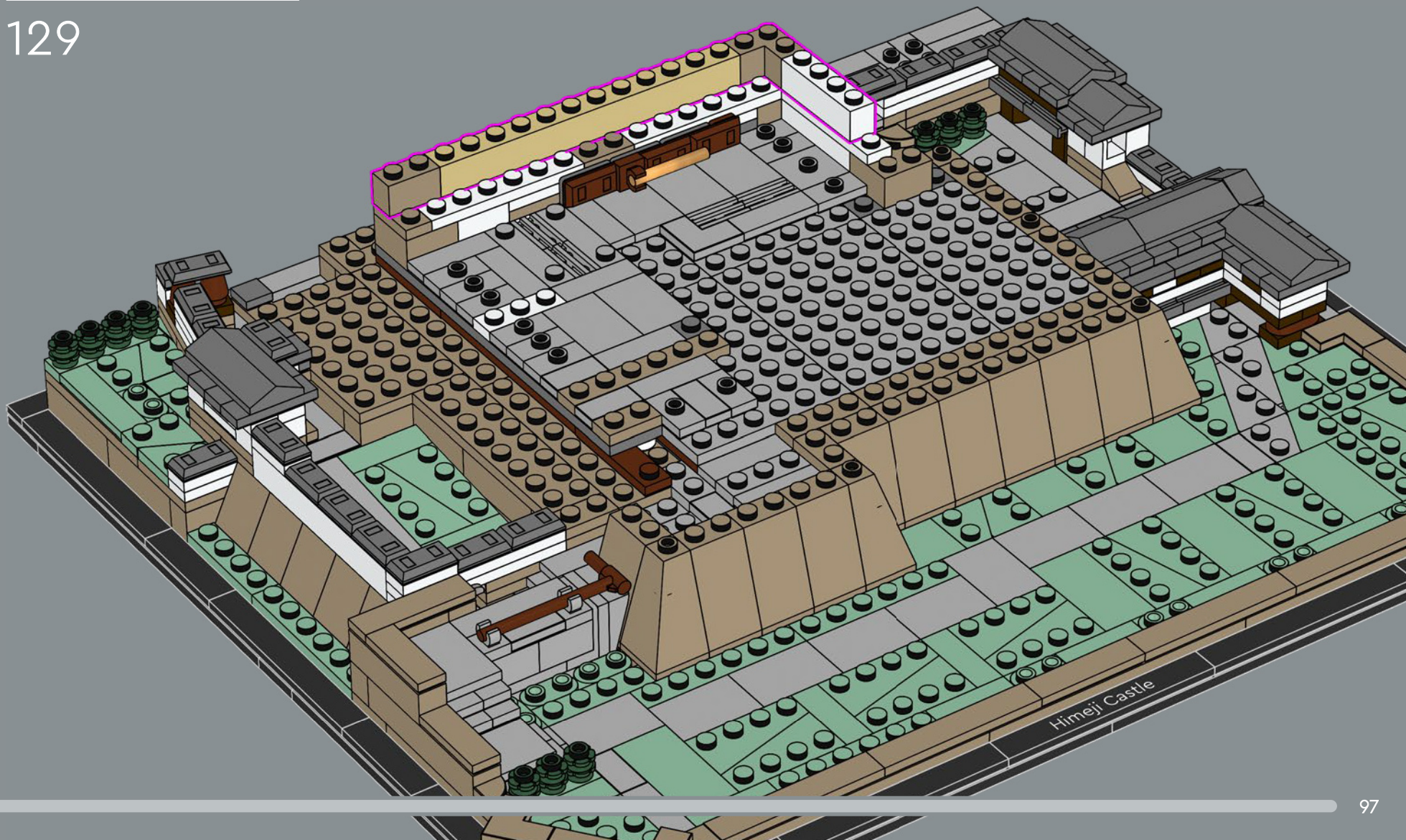

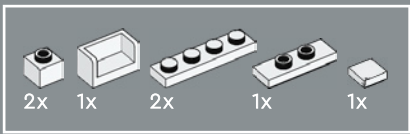

130

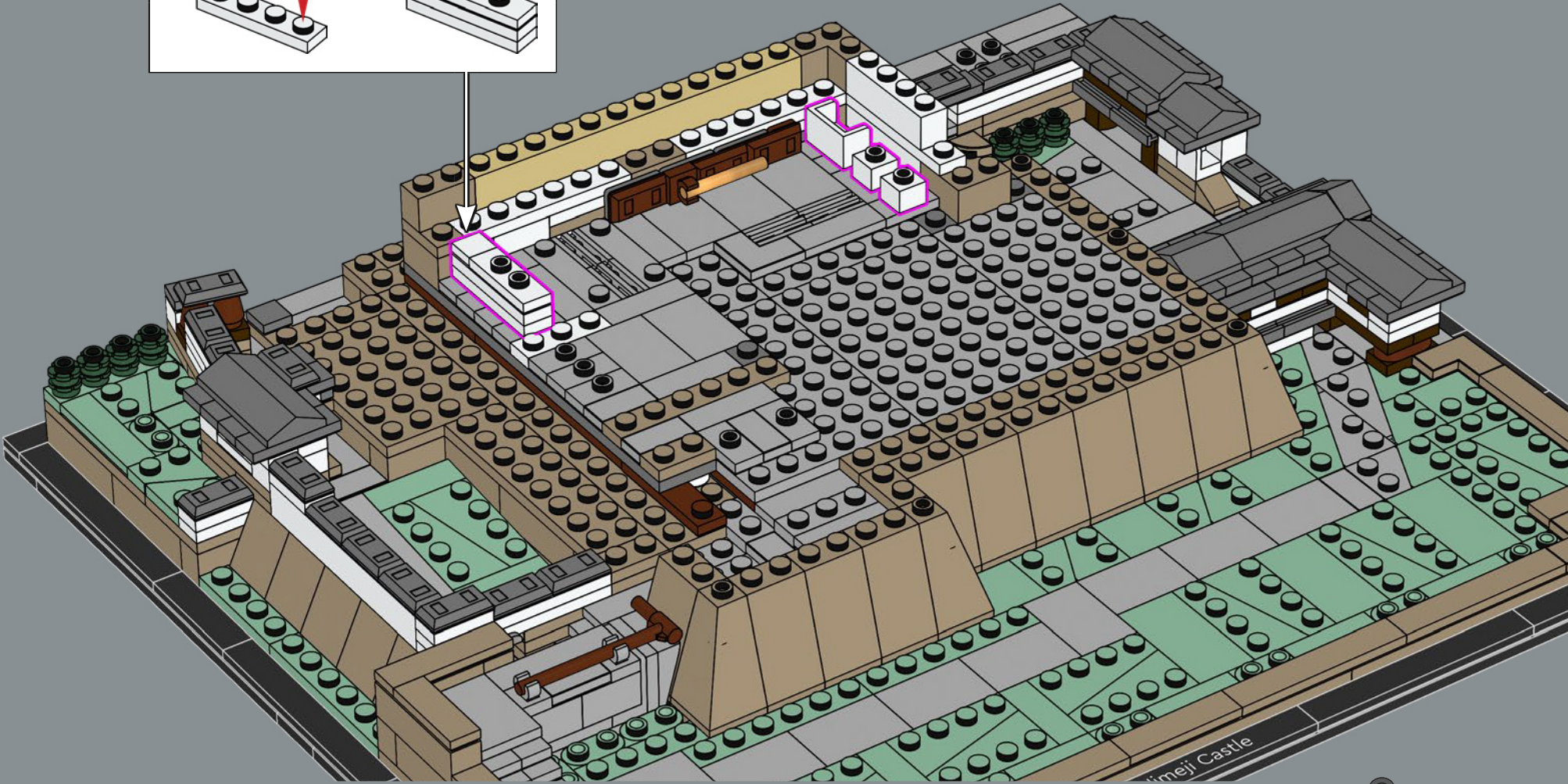
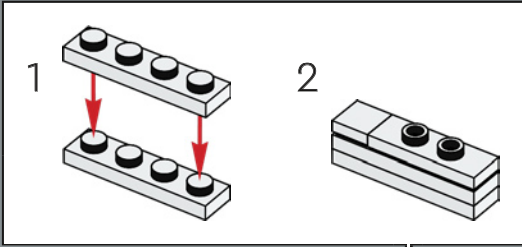

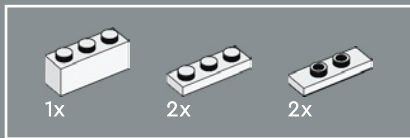

131

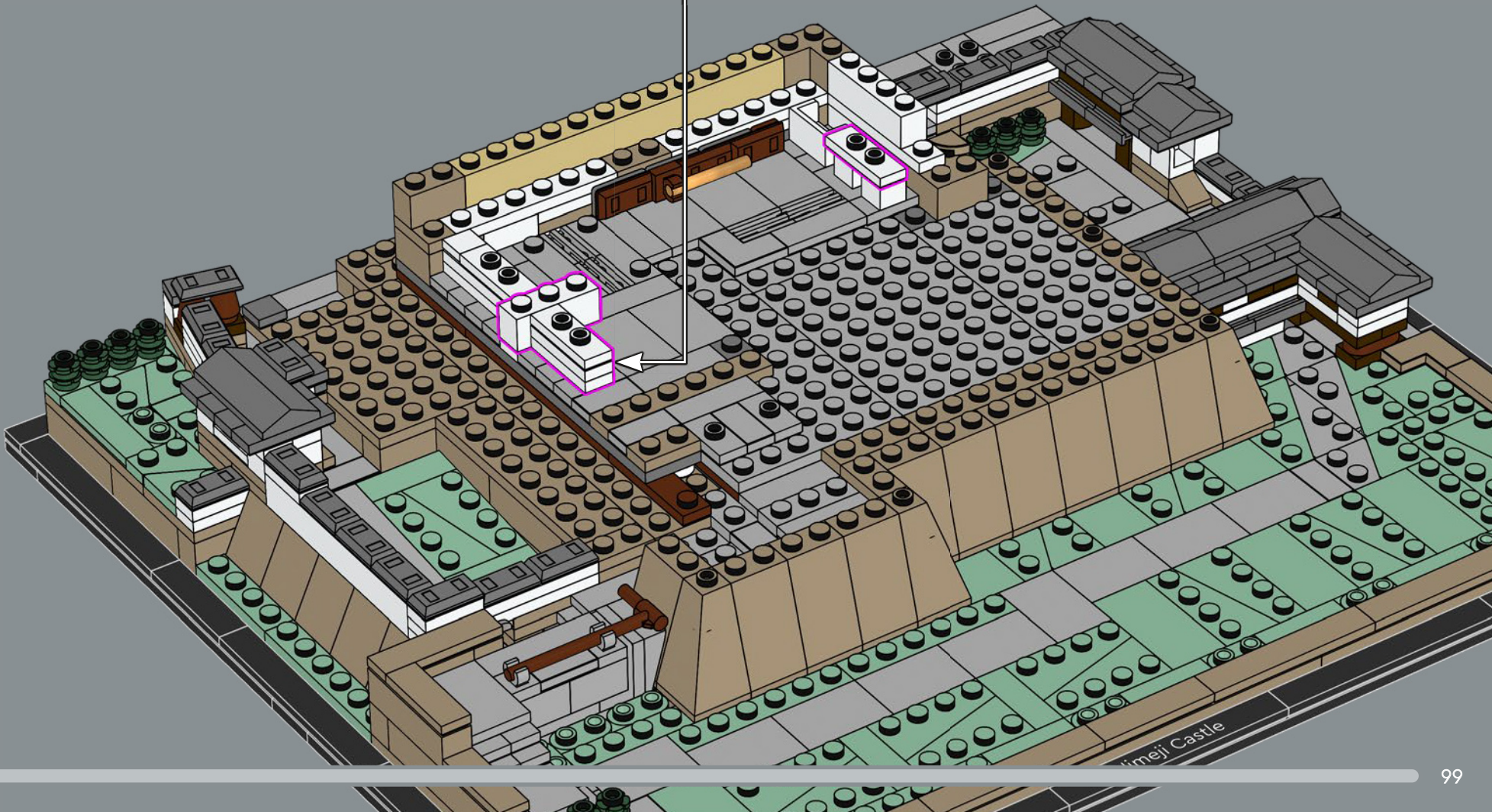
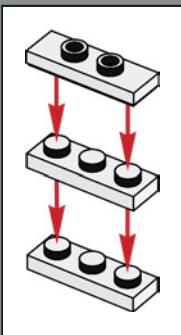

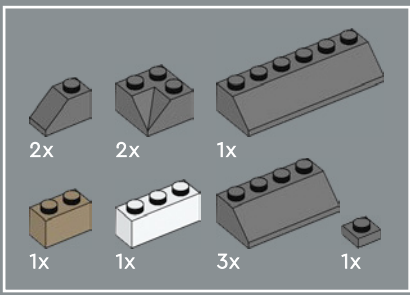

132

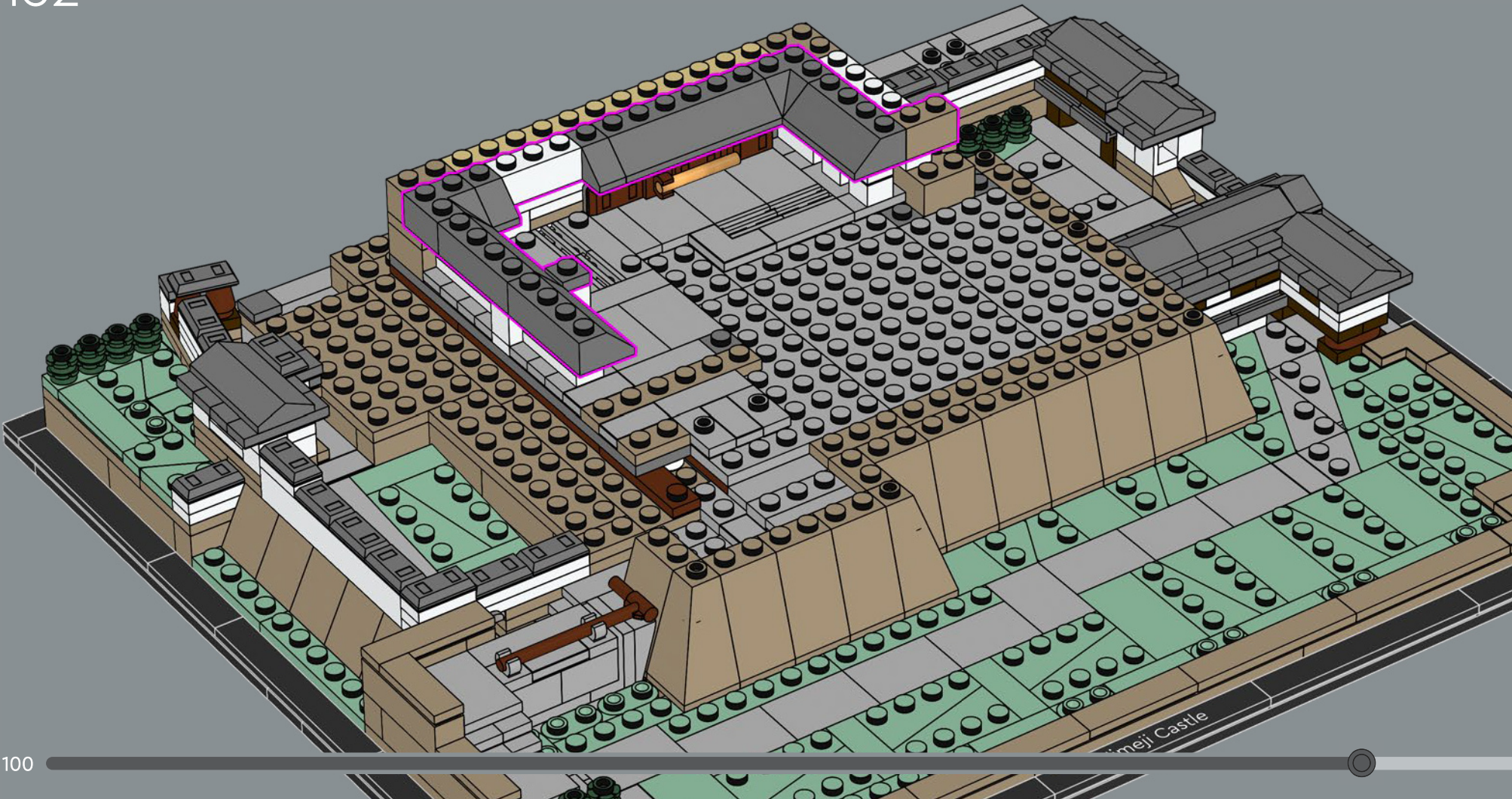

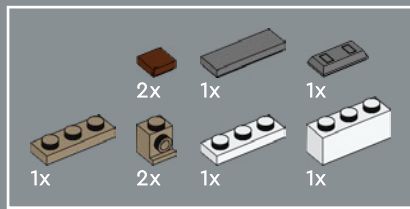

133

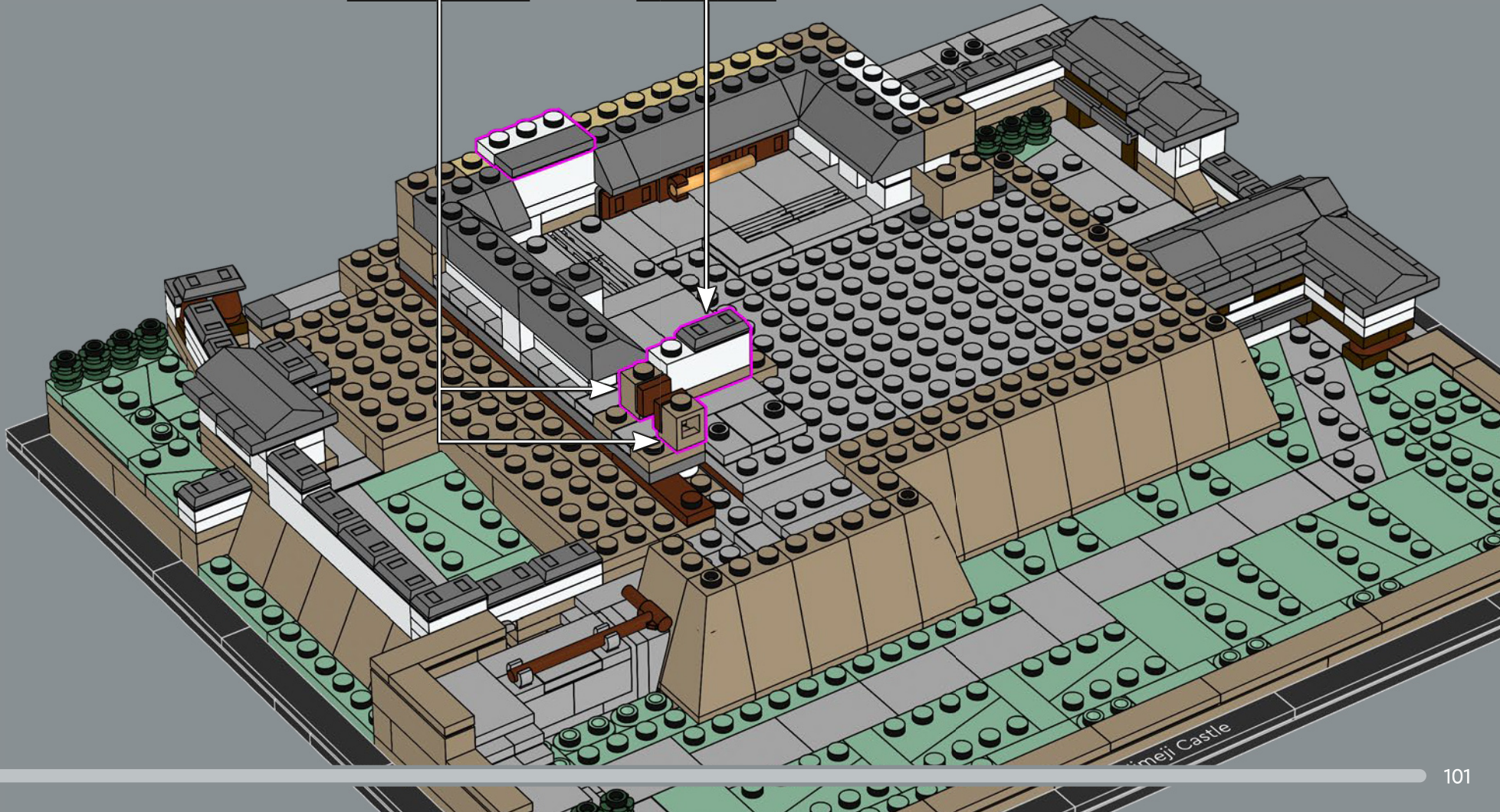
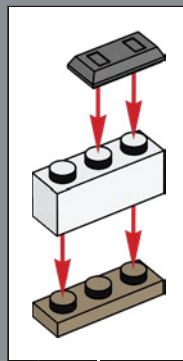
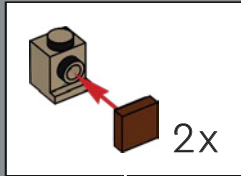

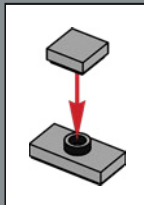
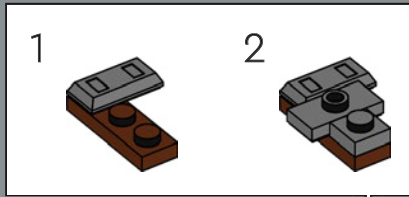
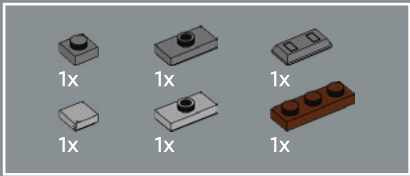

134

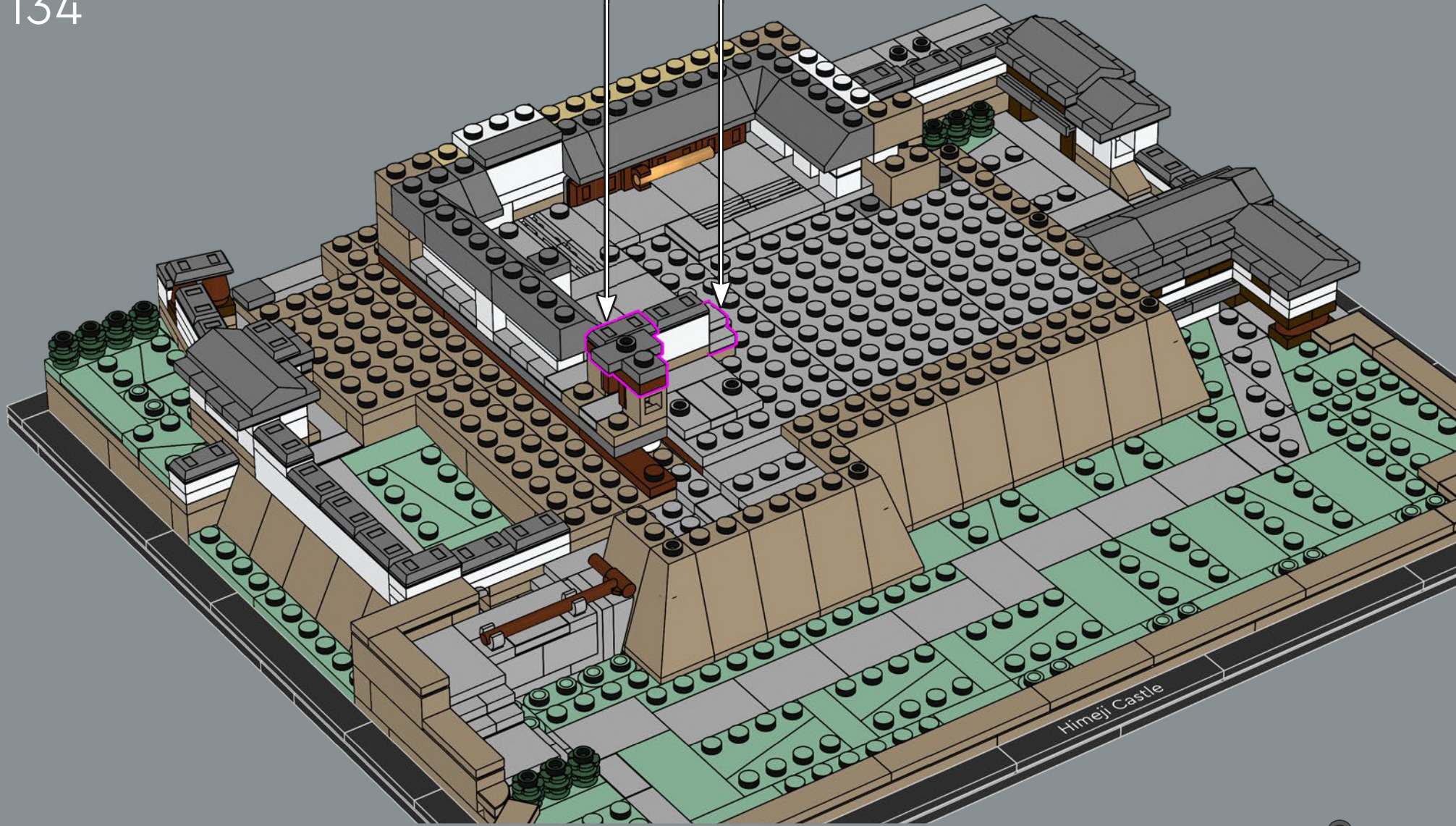

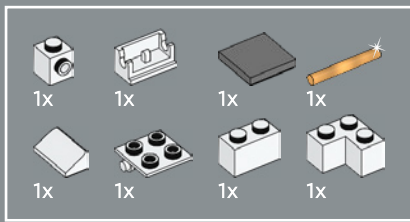

135

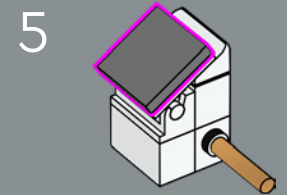
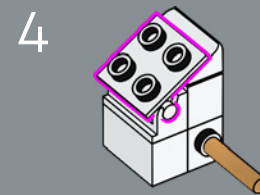
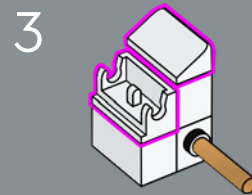
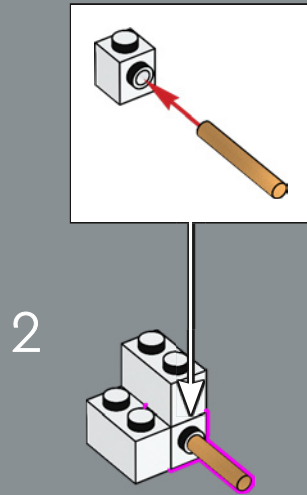
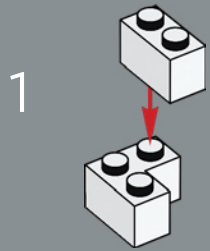

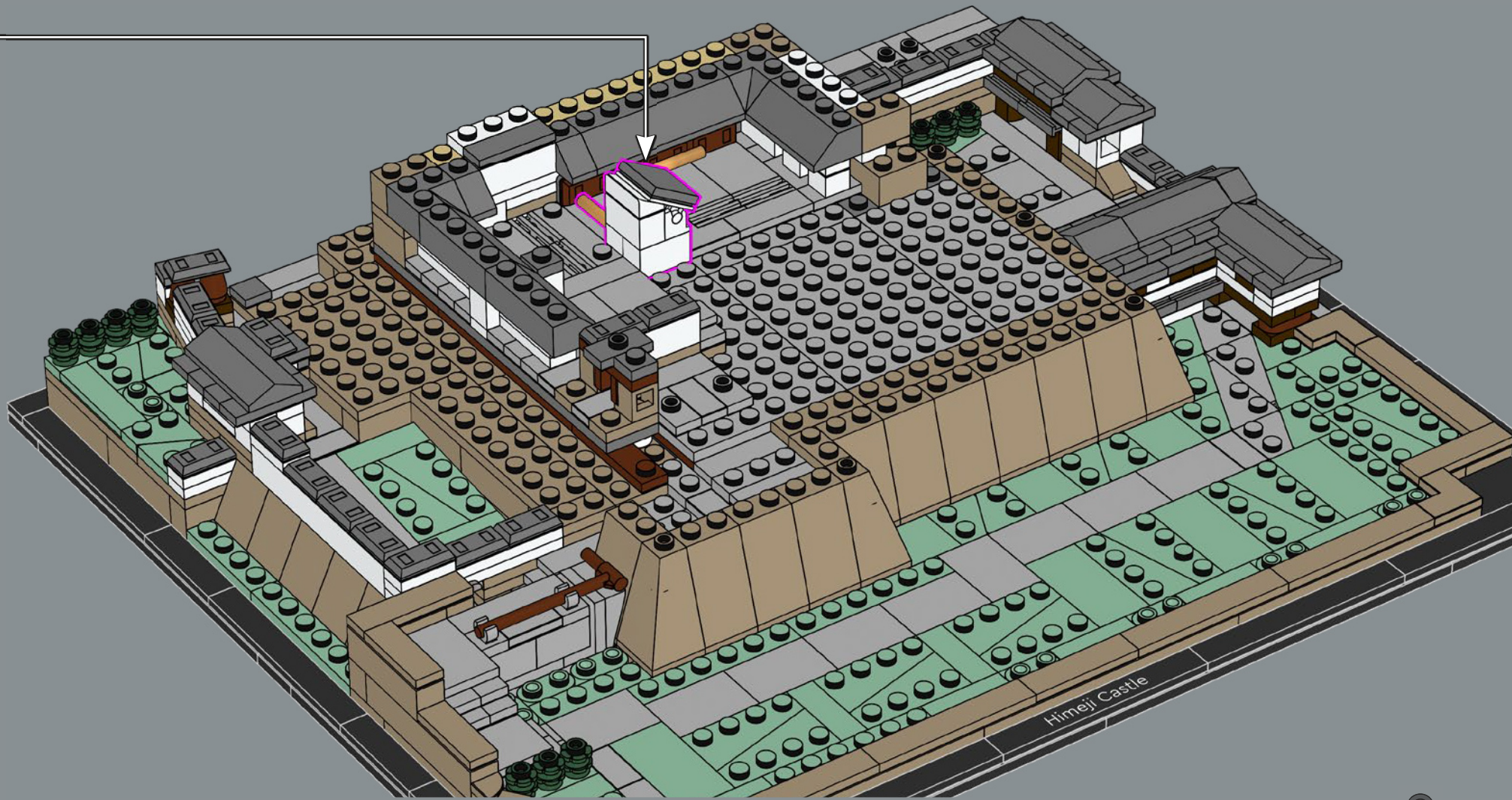

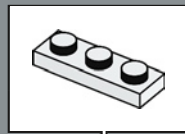
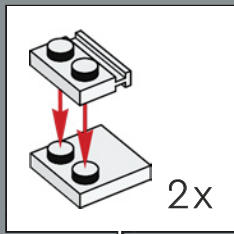
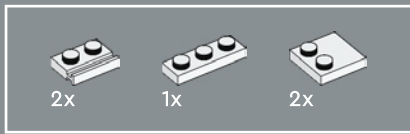

136



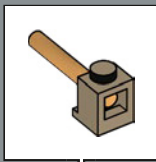
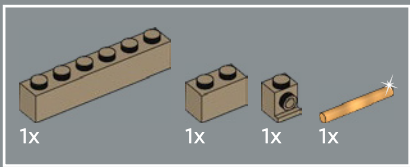

137

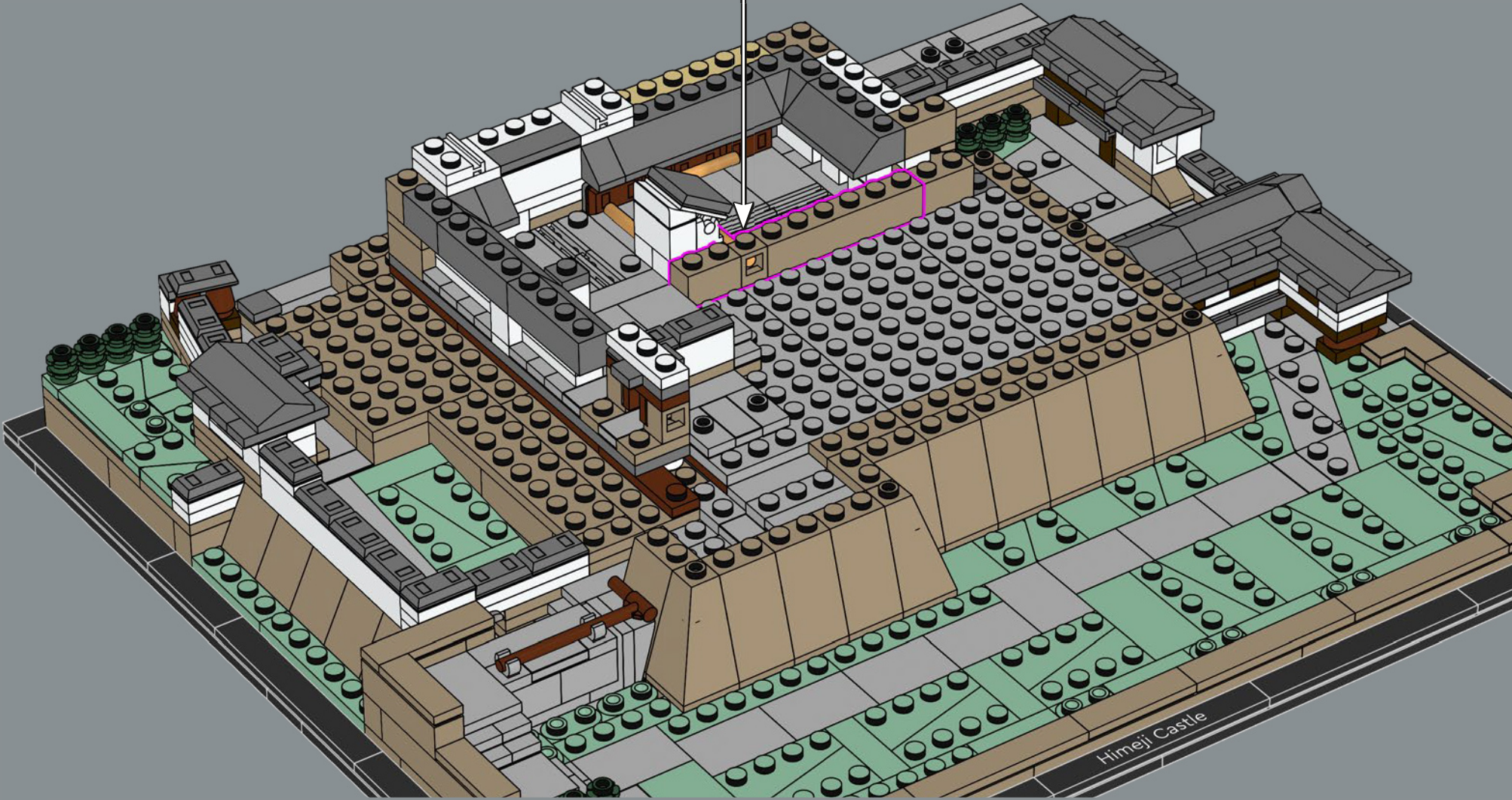

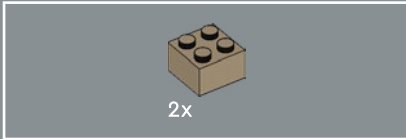
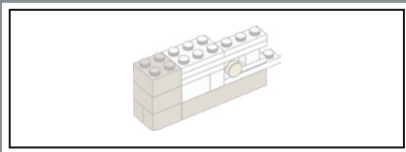

138

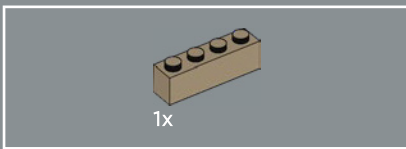
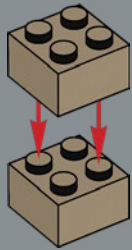

139

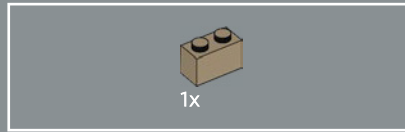
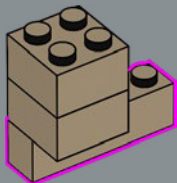

140

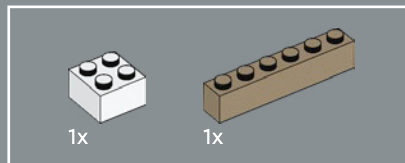
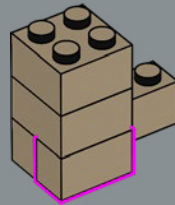

141

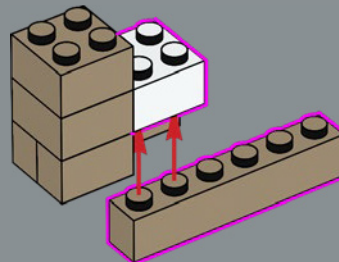

142

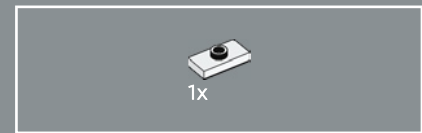
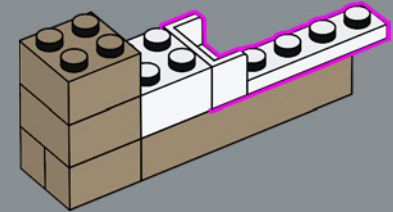

143

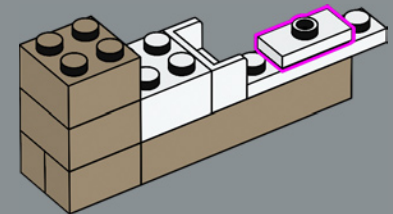

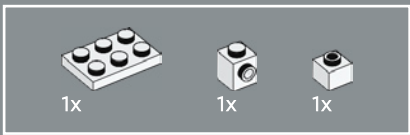

144

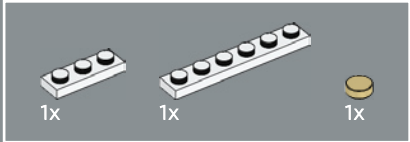
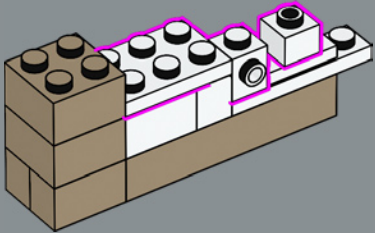

145

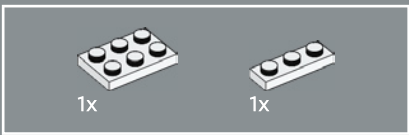
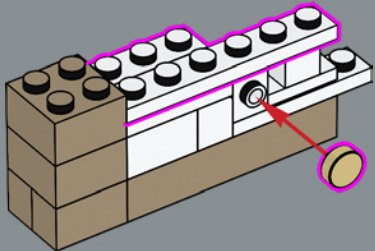

146

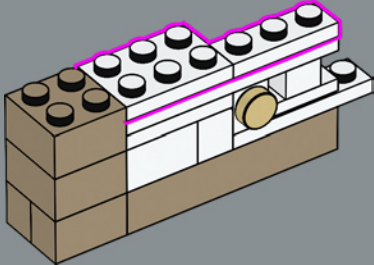

147

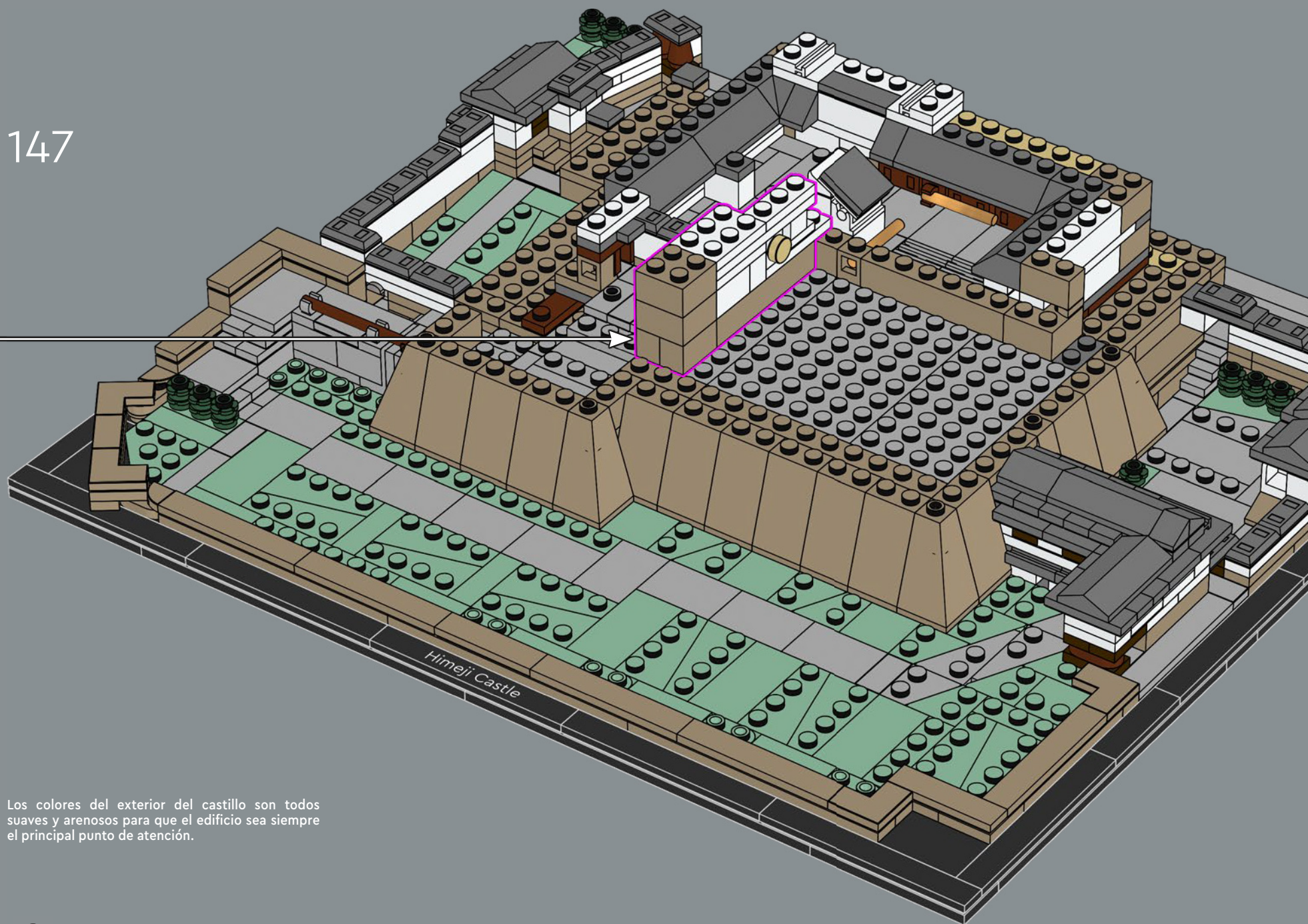

Los colores del exterior del castillo son todos suaves y arenosos para que el edificio sea siempre el principal punto de atención.

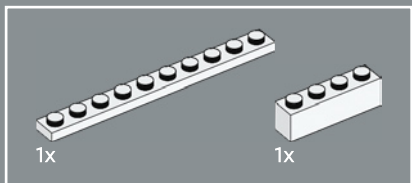

148

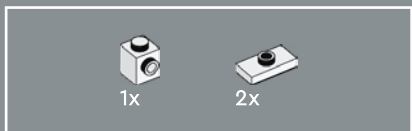
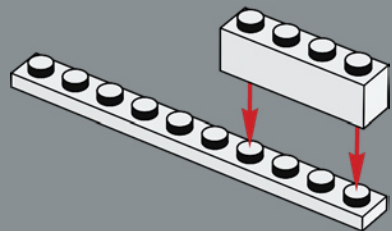

149

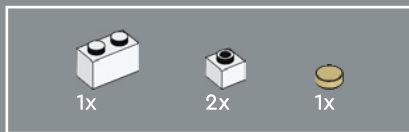
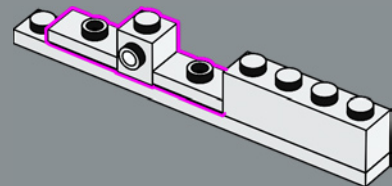

150

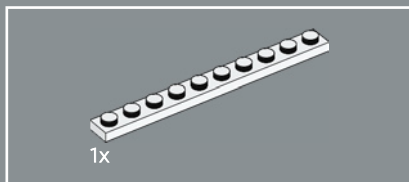
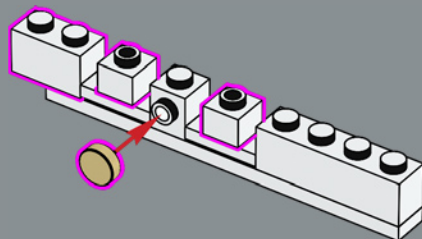

151

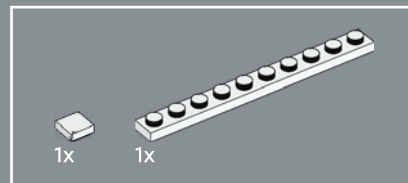
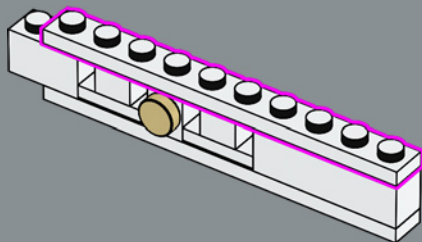

152

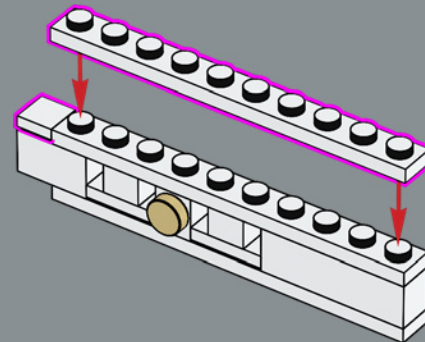

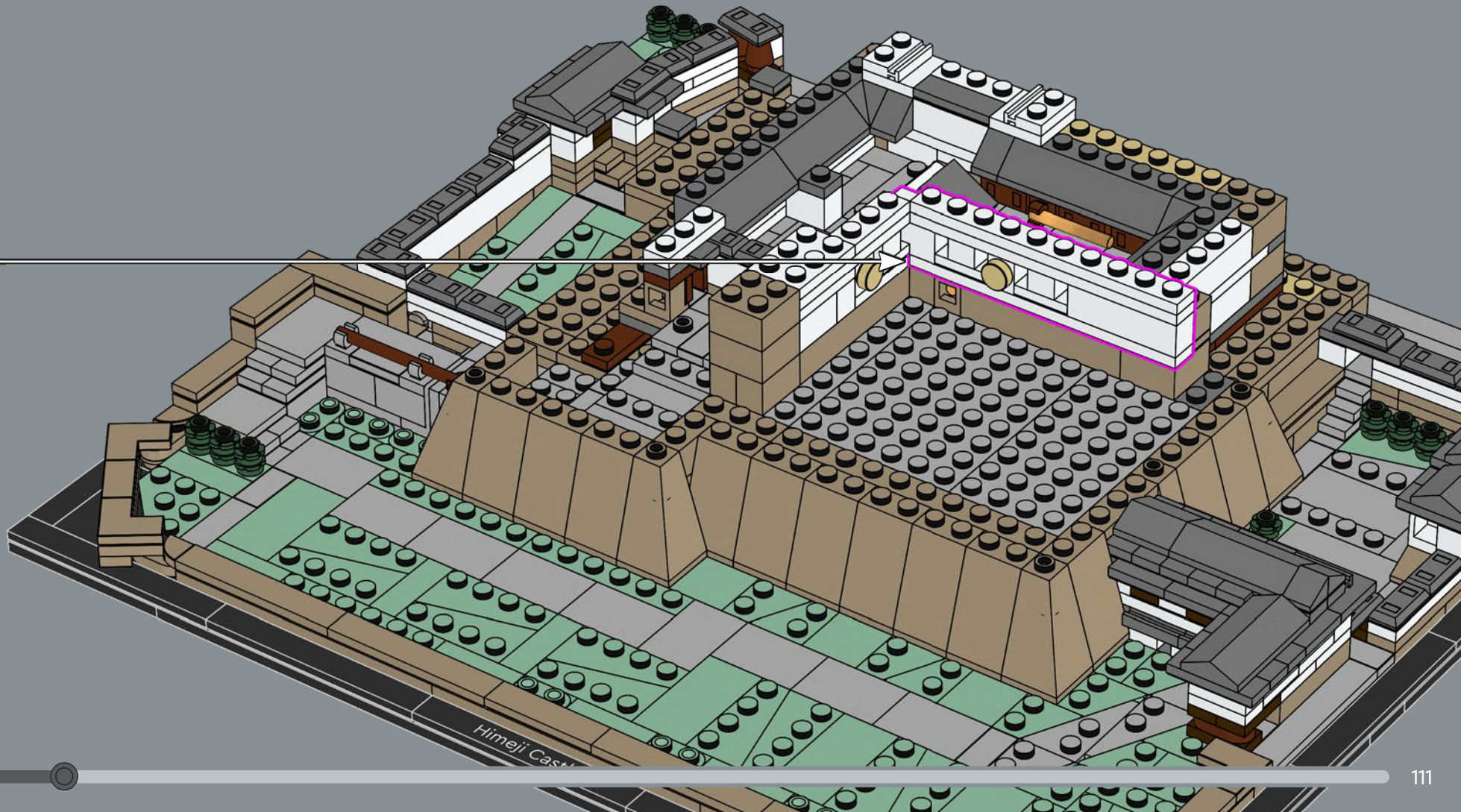

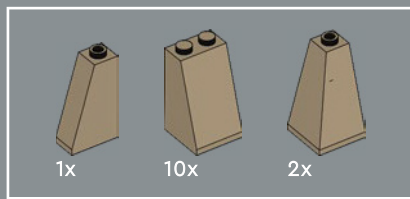

154

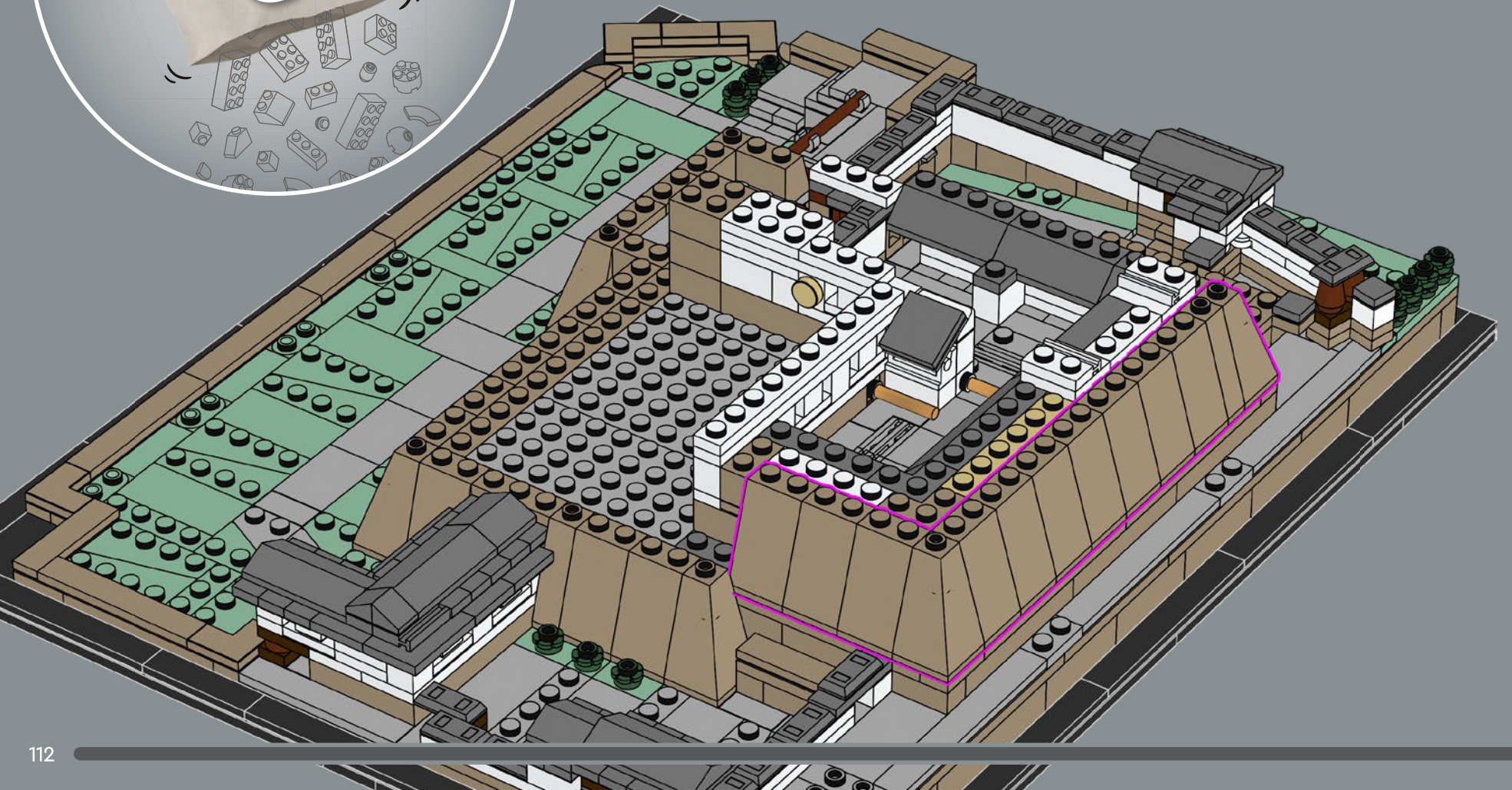

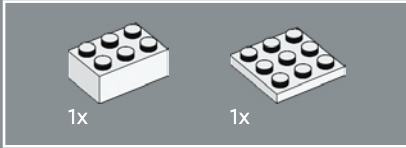

155

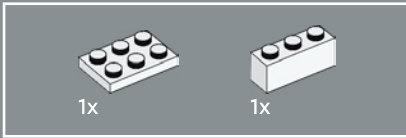
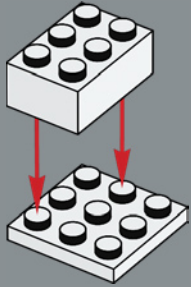

156

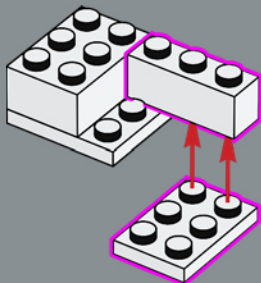

157

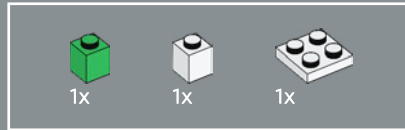
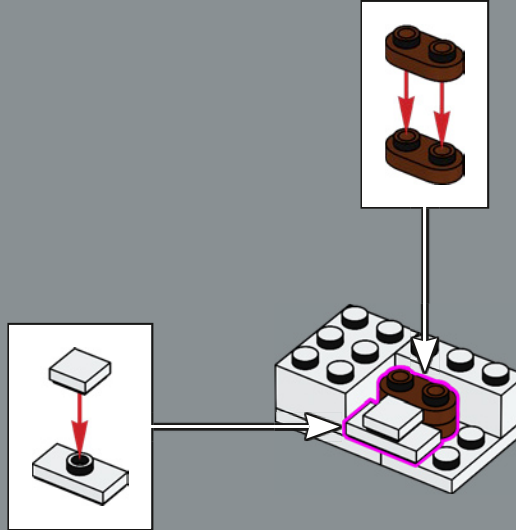

158

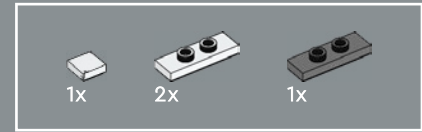
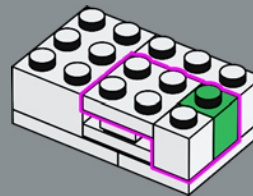

159

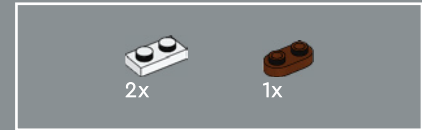
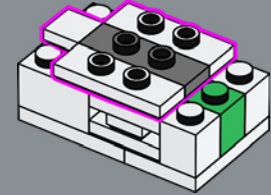

160

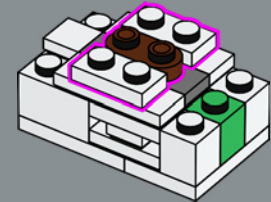

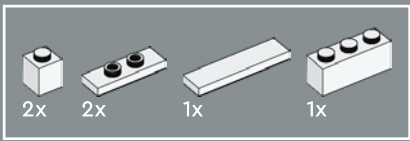

161

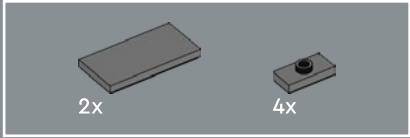
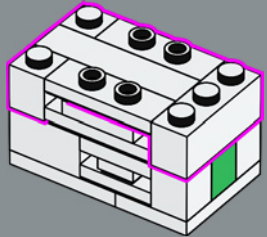

162

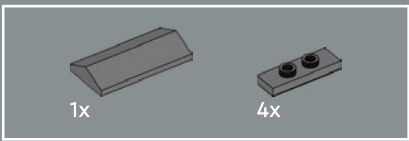
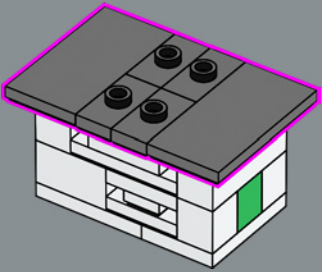

163

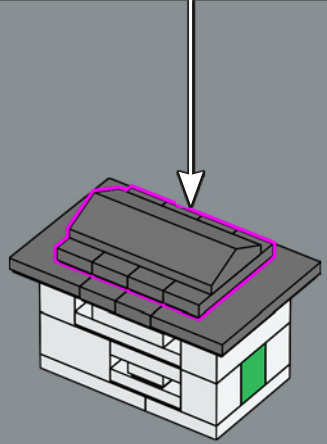
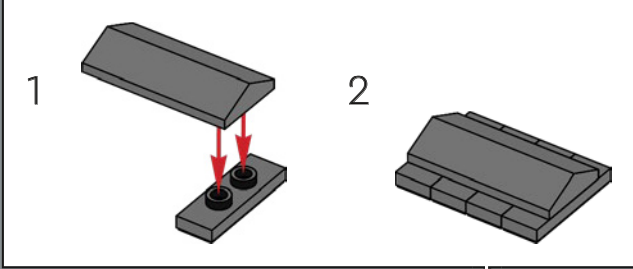

164

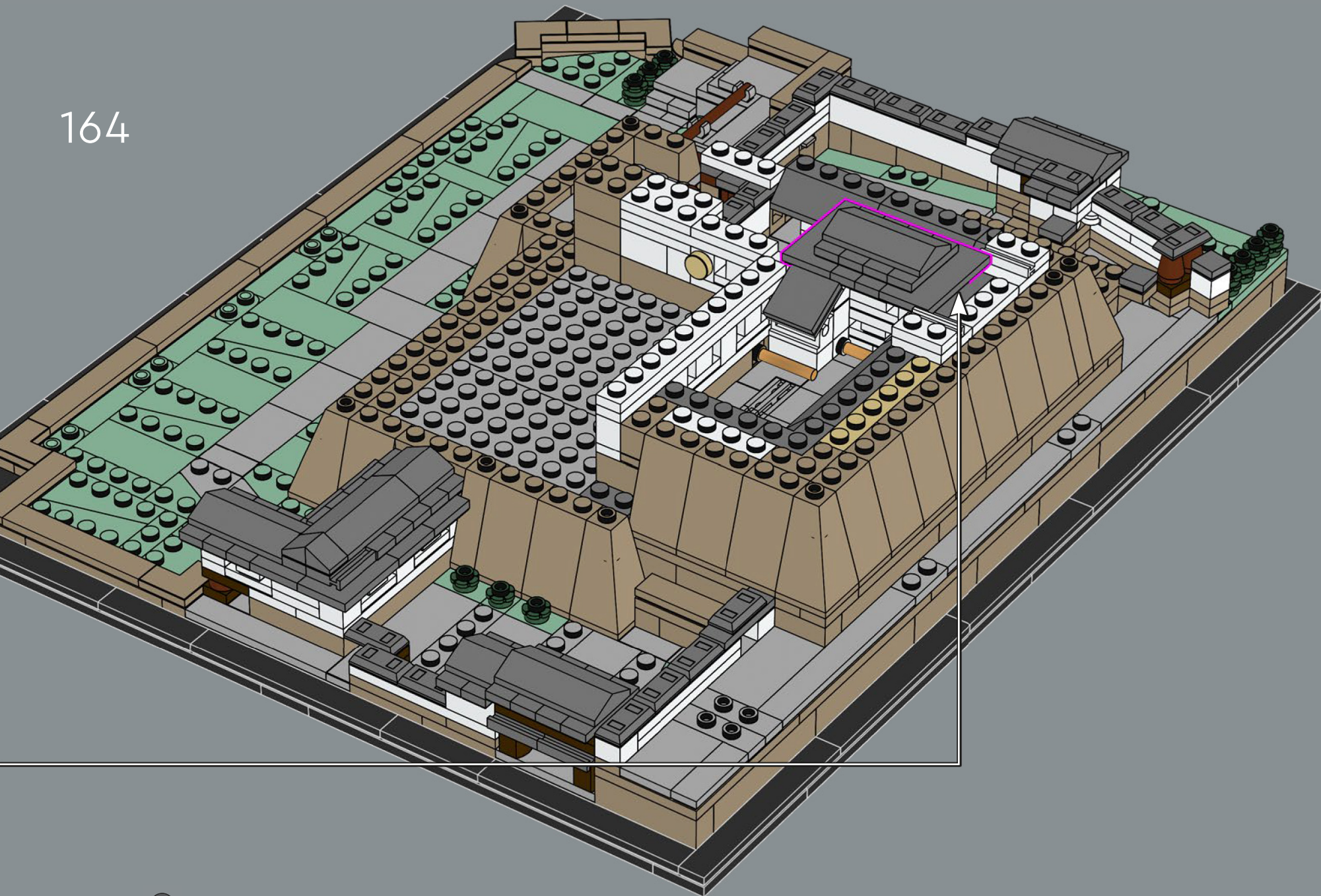

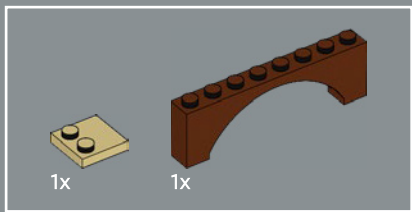

165

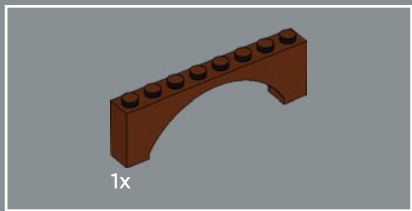
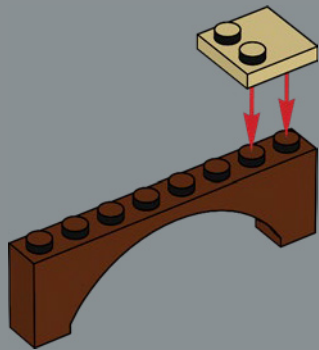

166

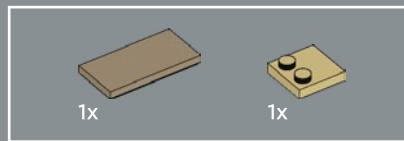
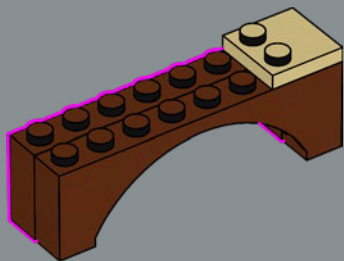

167

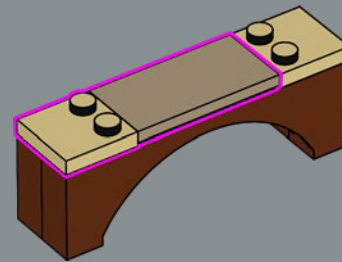

168

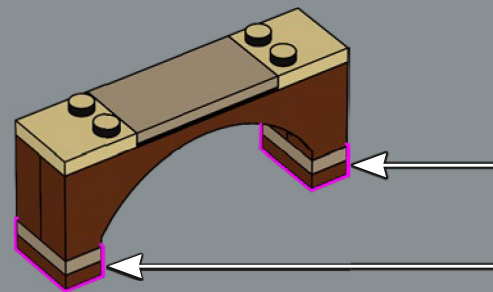
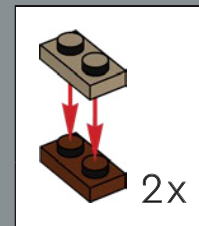

169

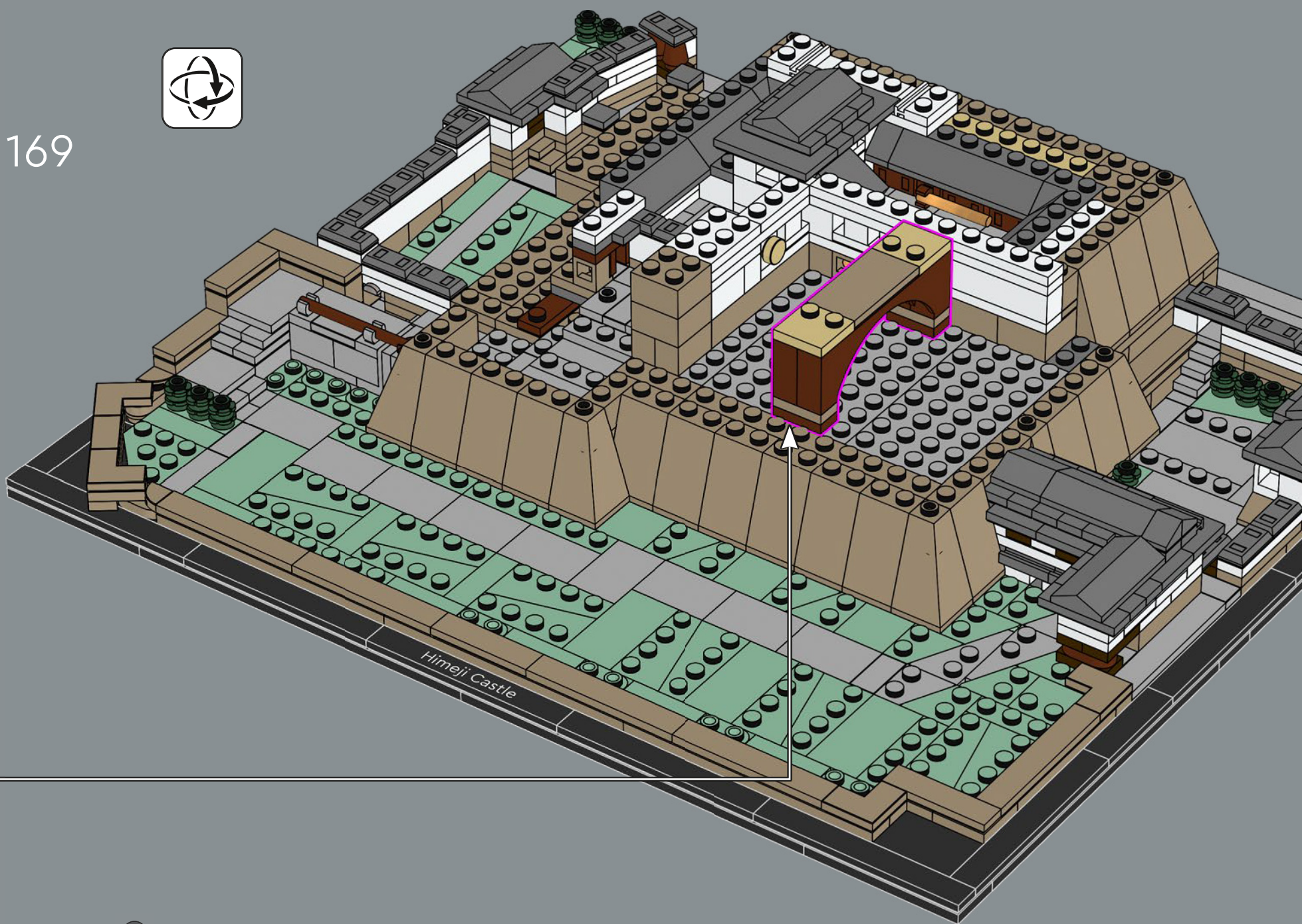

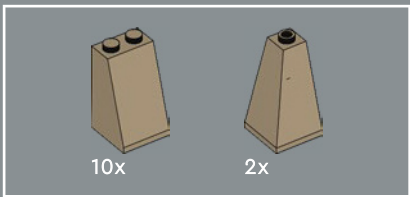

170

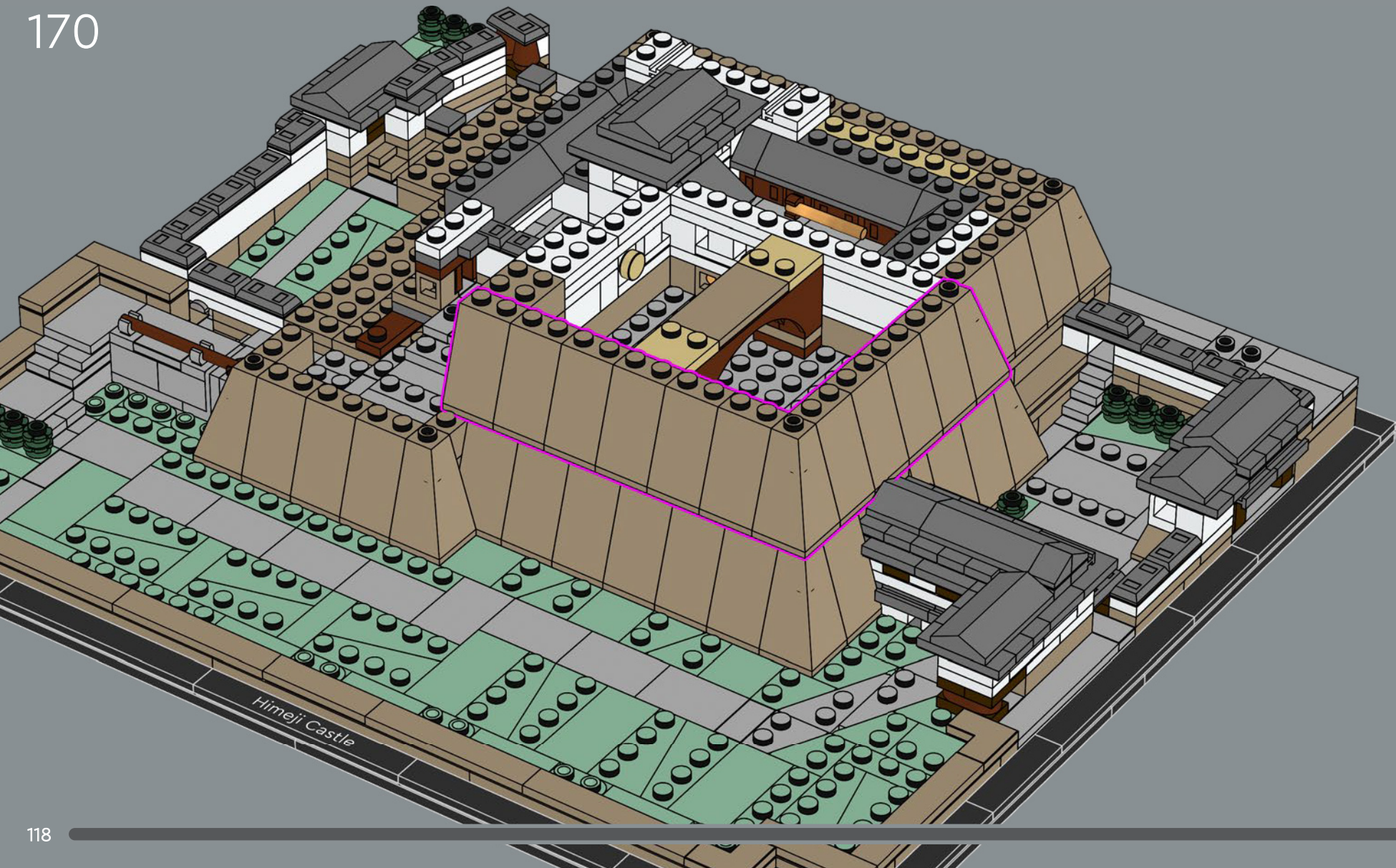

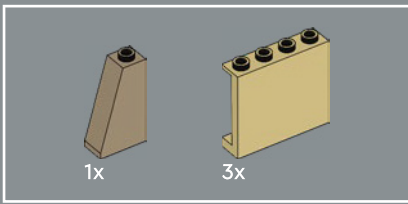

171



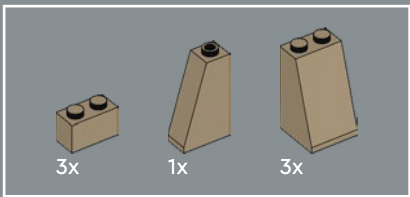

172

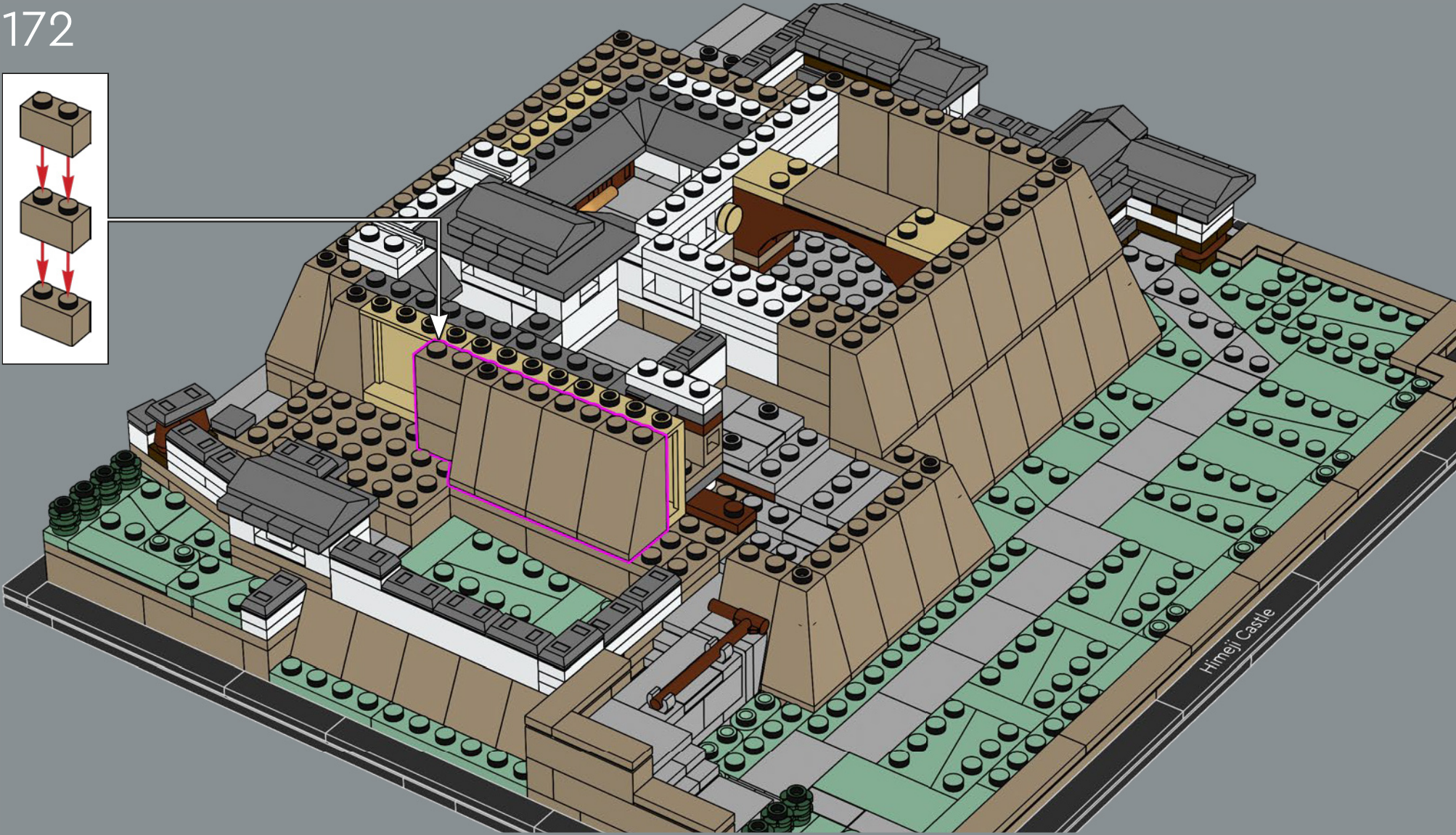
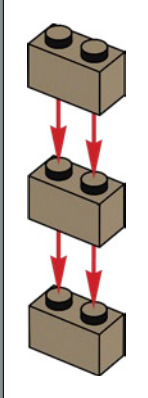

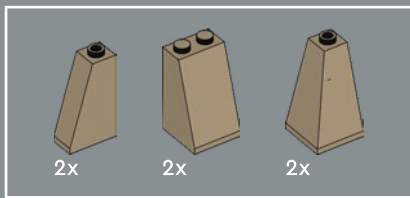

173



Himeji Castle

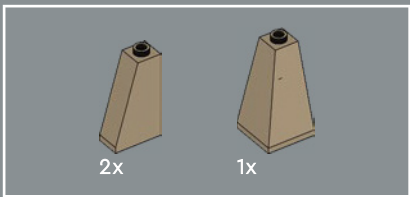

174

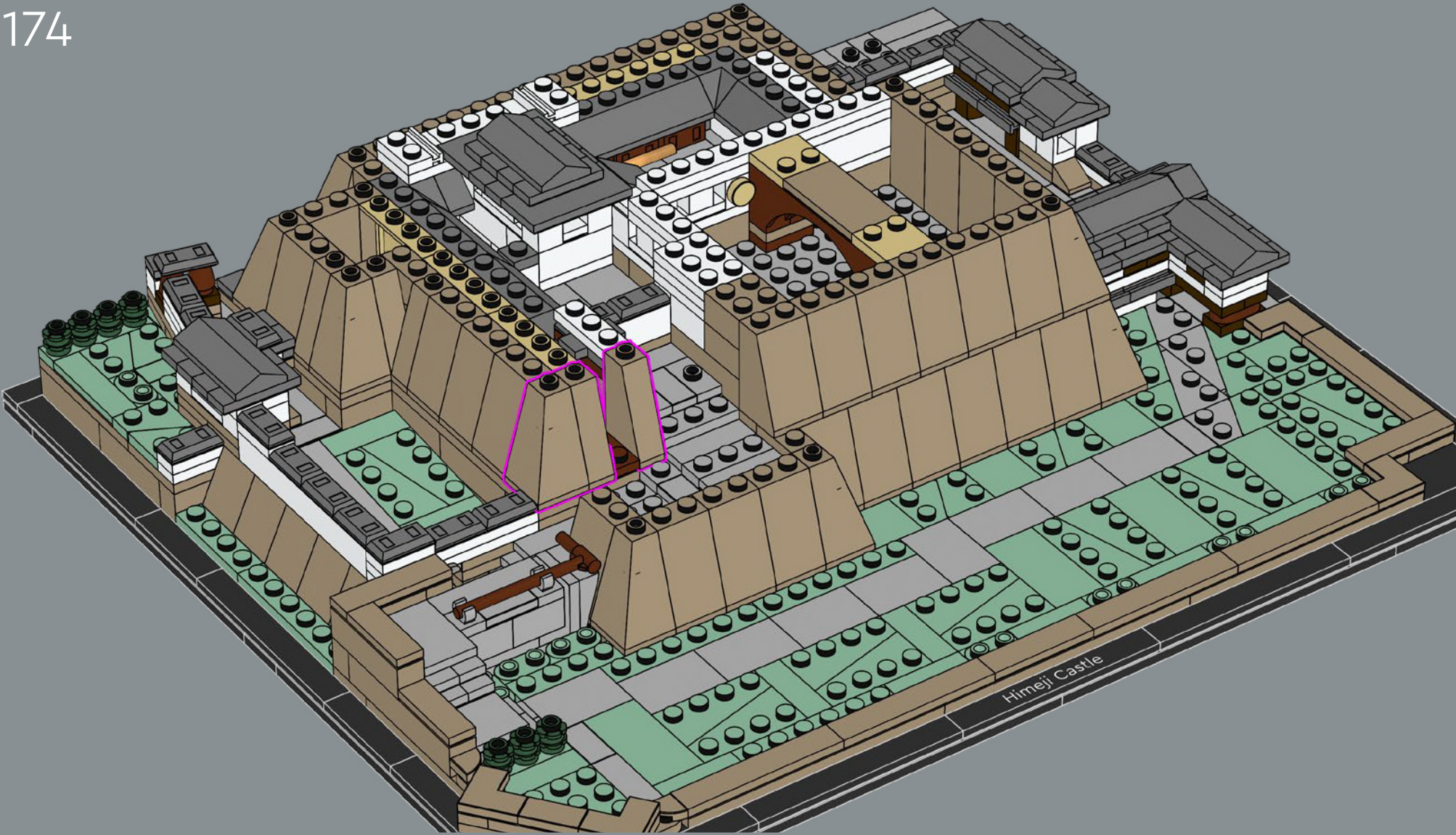

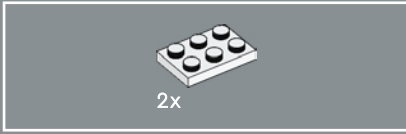
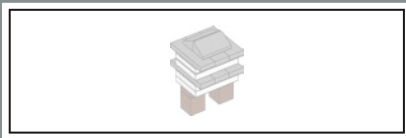

175

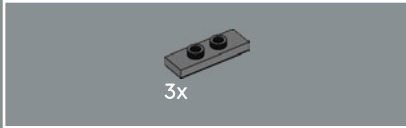
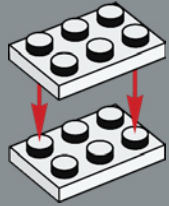

176

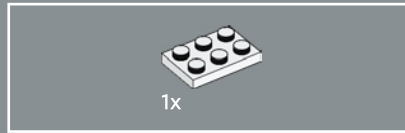

177

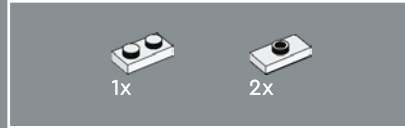
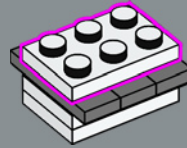

178

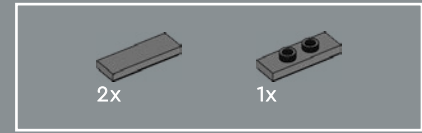
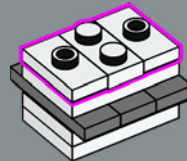

179

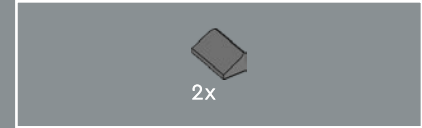
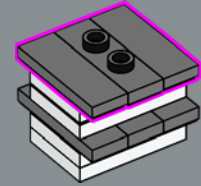

180

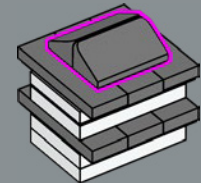

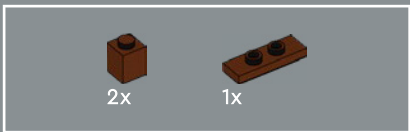

181

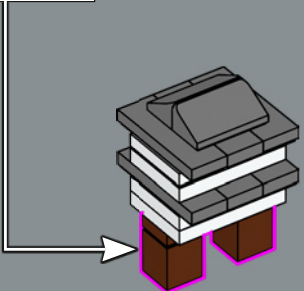
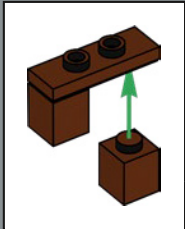

182

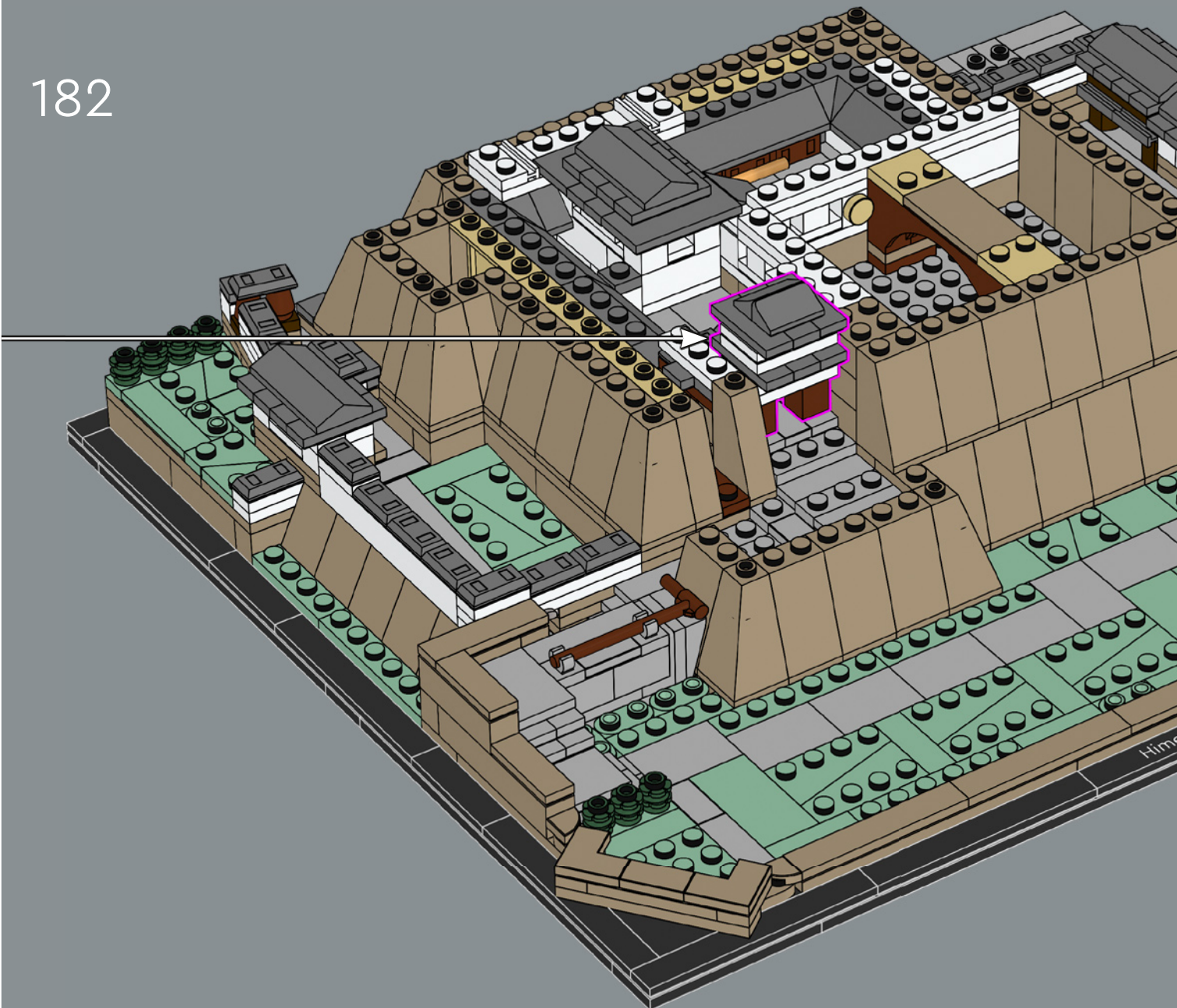

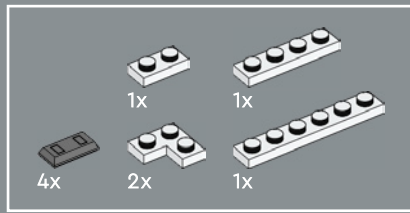

183

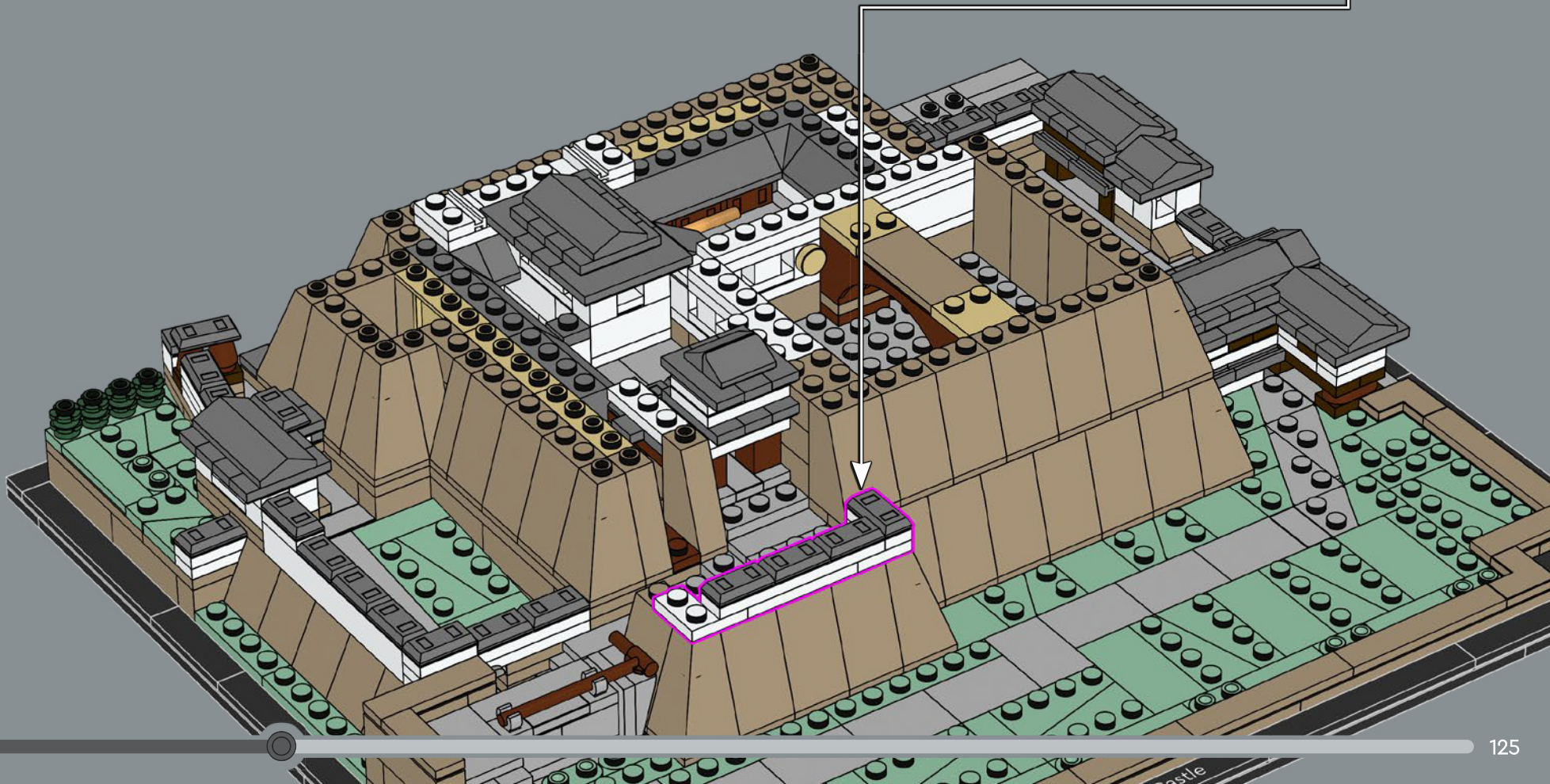
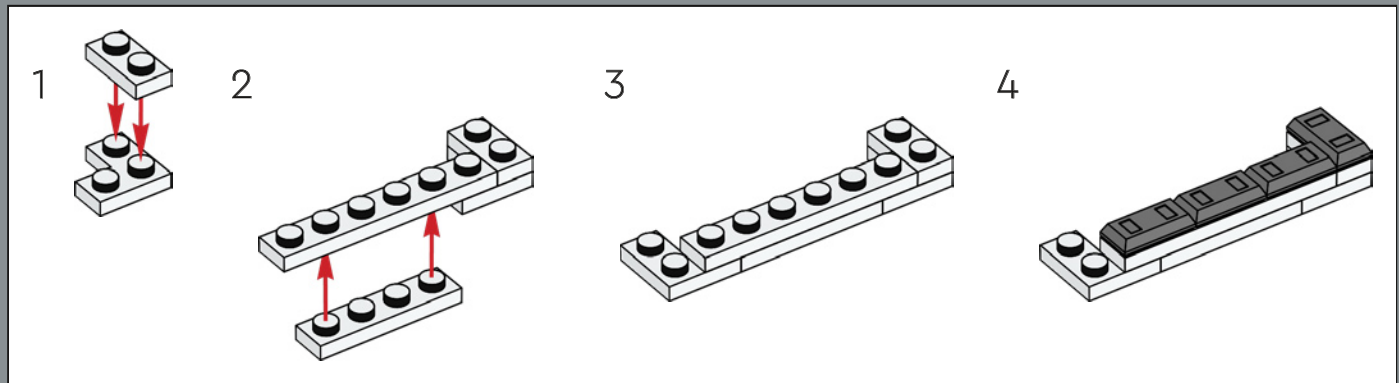

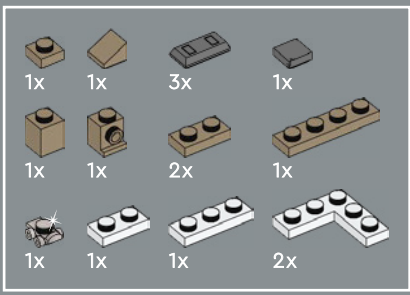

184

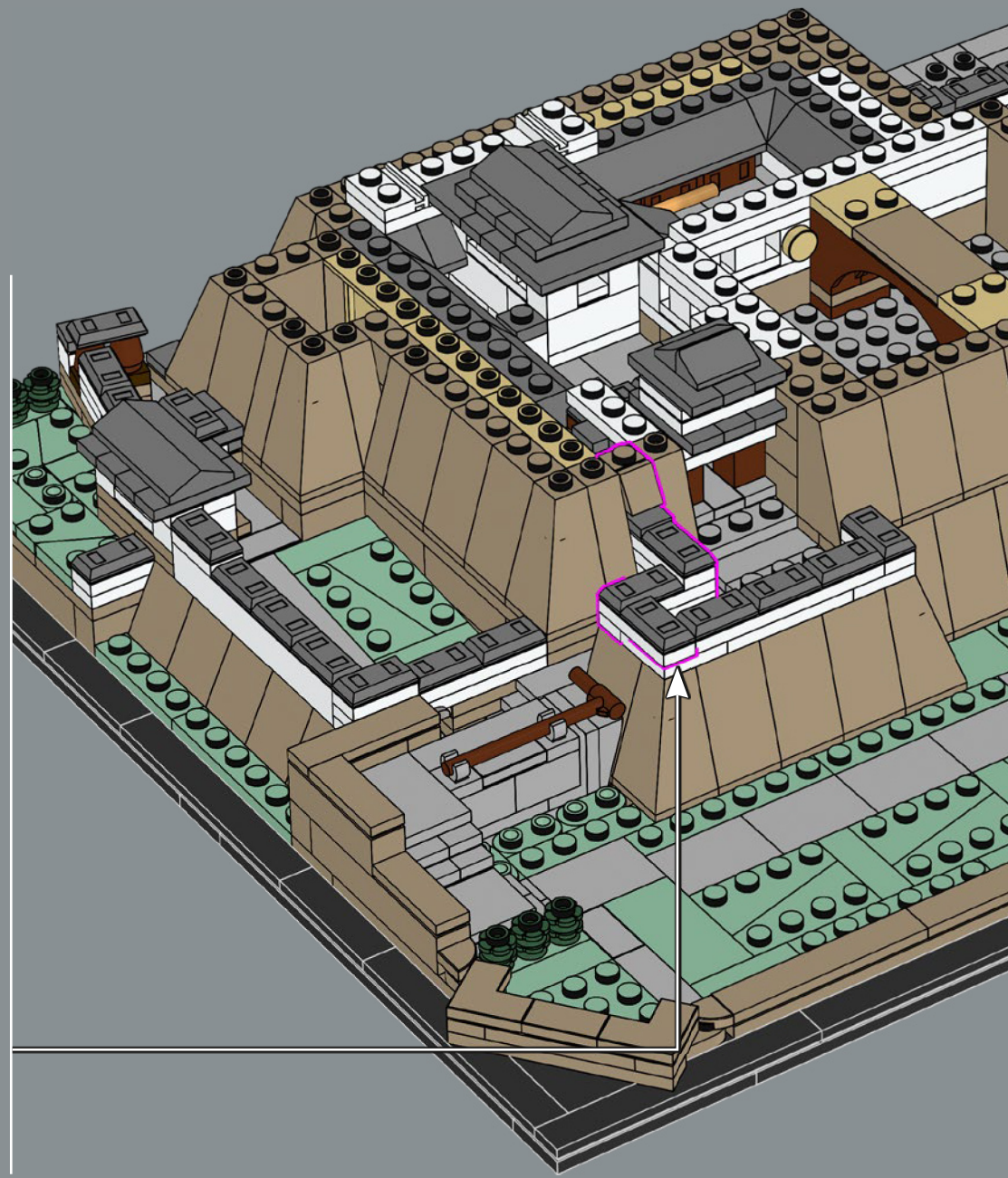
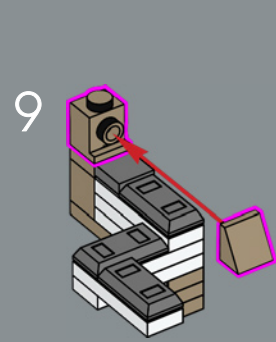
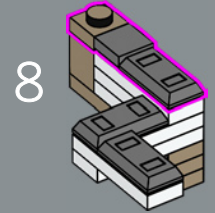
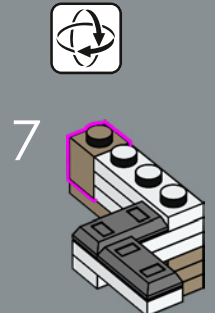
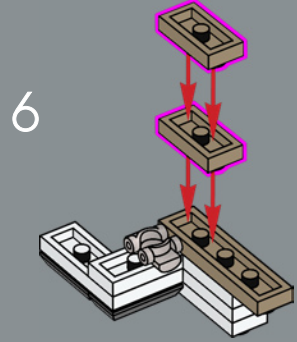
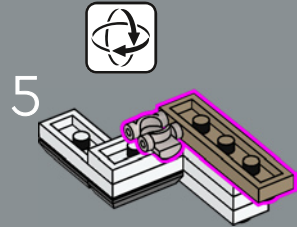
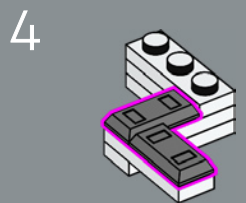
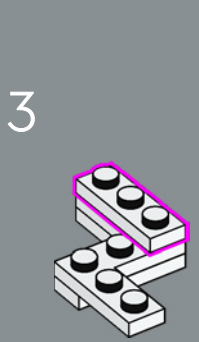
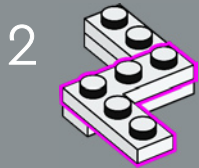
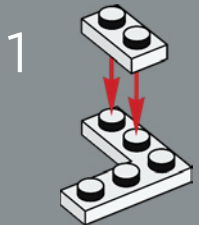

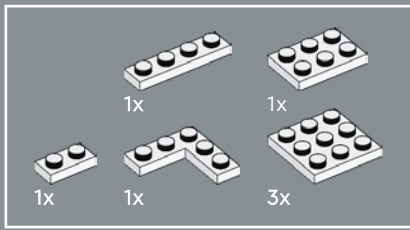

185

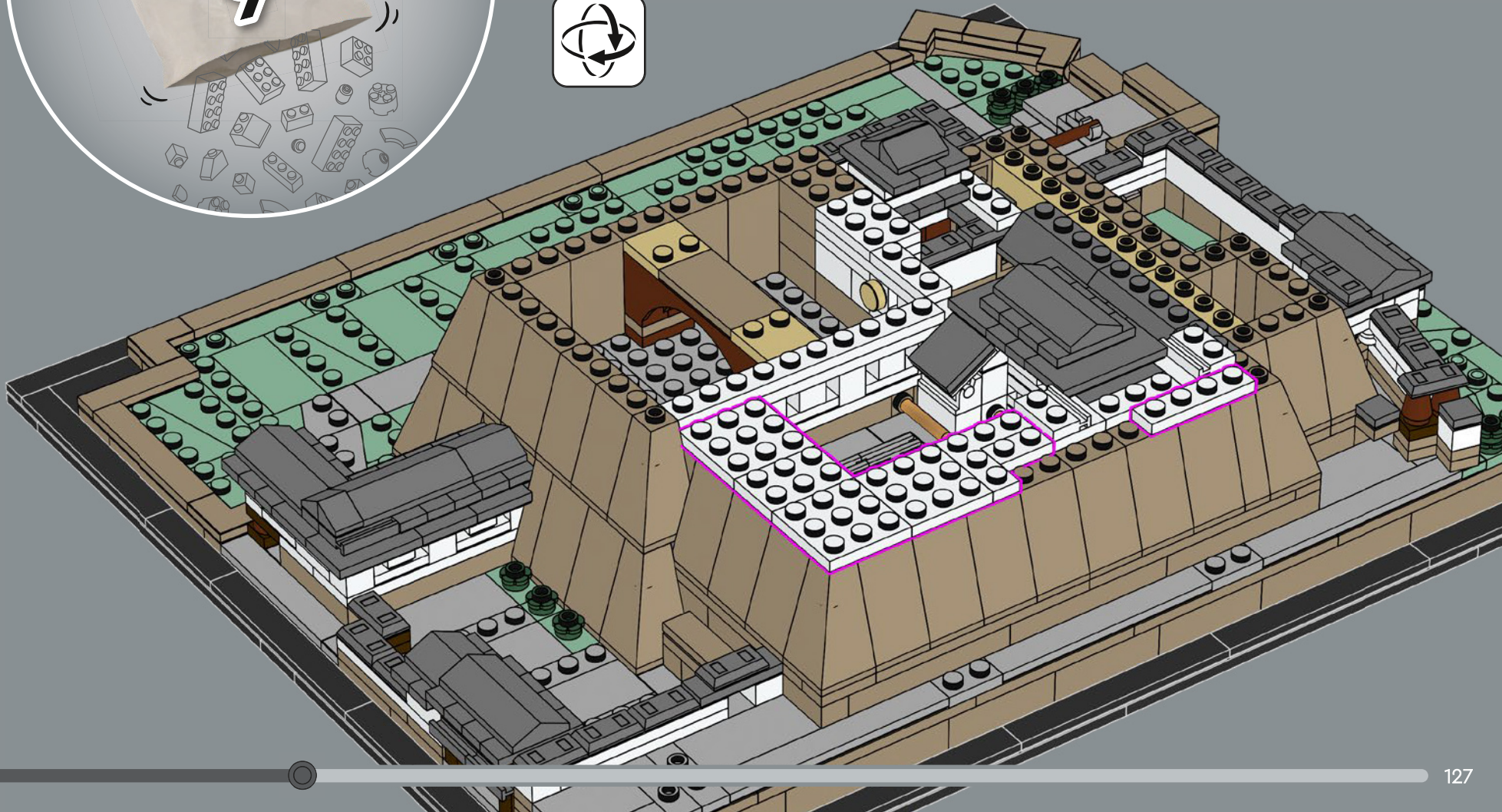

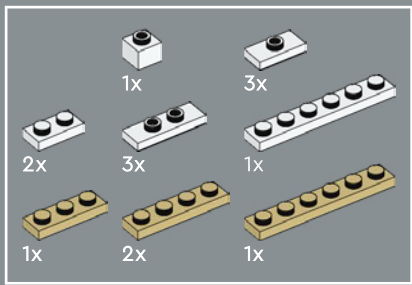

186

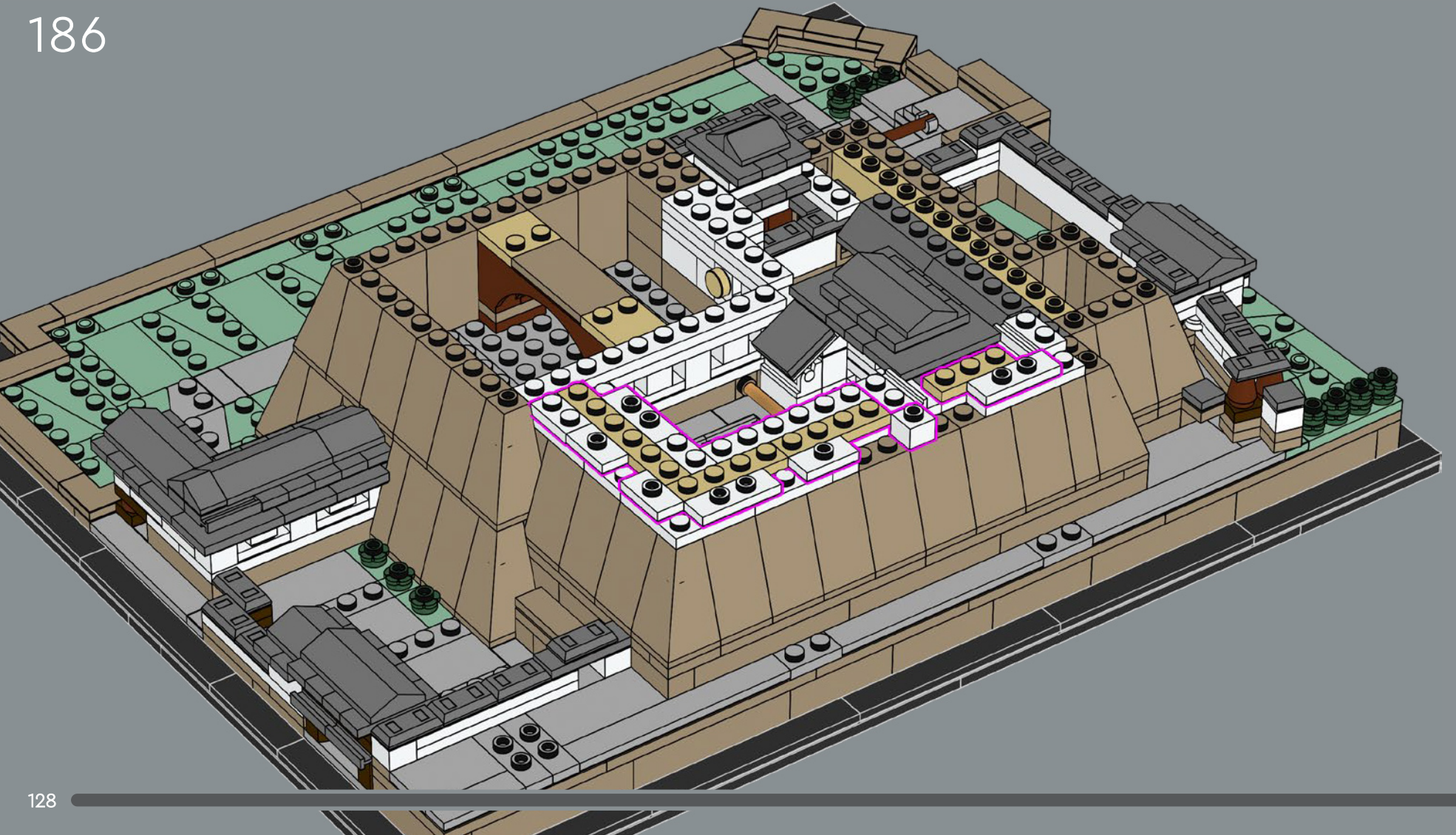

Durante la restauración de 2009–2015, varios lados del andamiaje exterior se cubrieron con representaciones artísticas lineales del castillo para que el emblemático monumento siguiera siendo visible en el horizonte de Himeji.

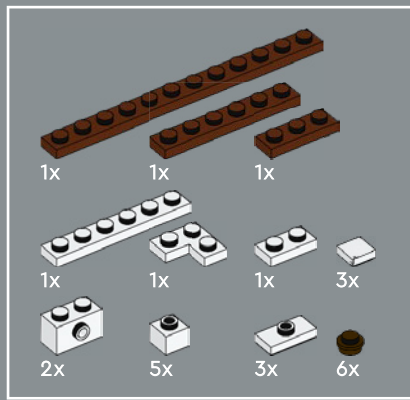

187



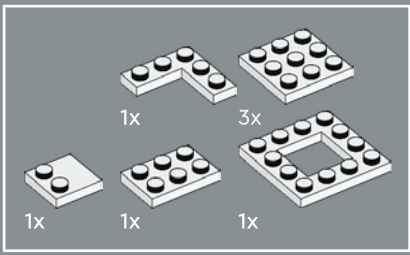

188

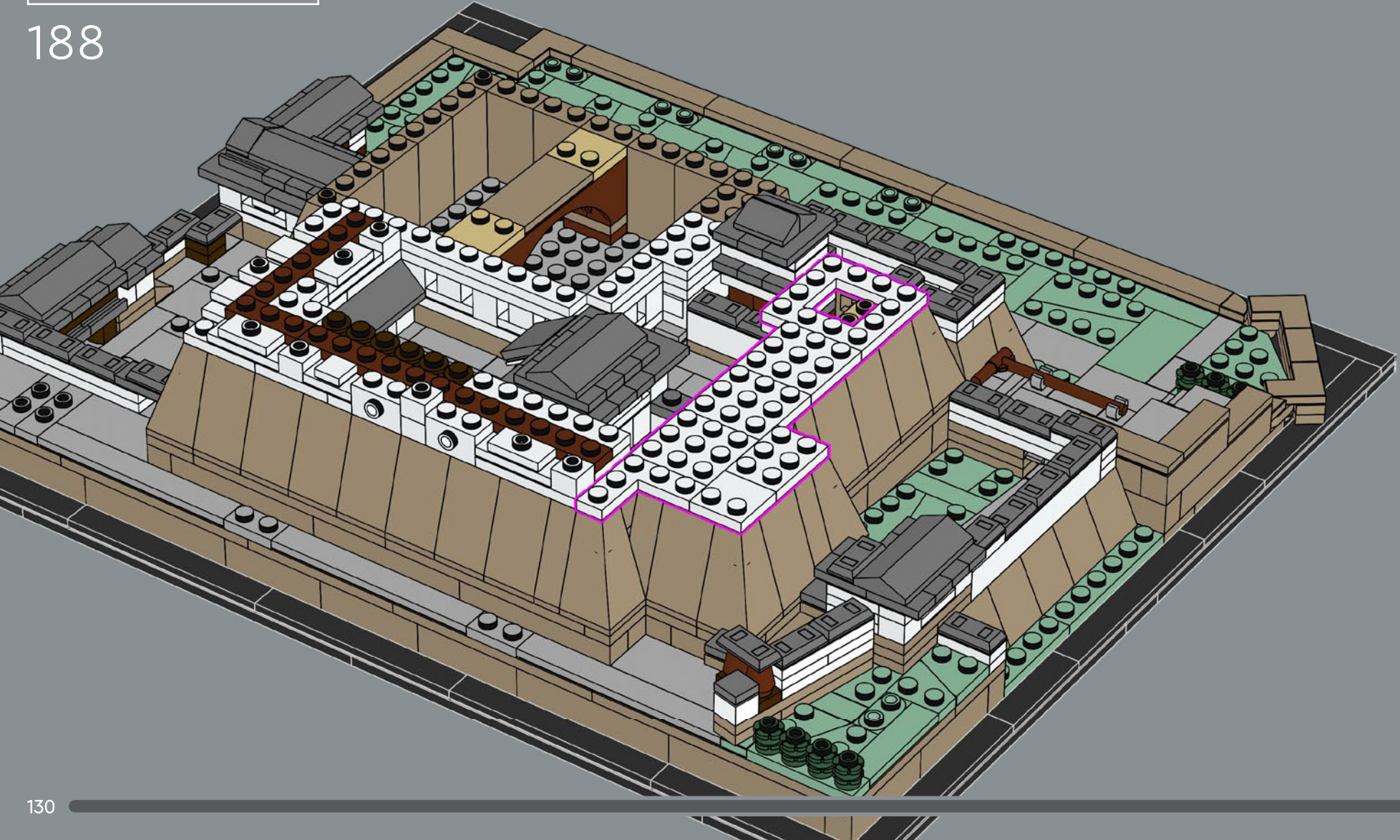

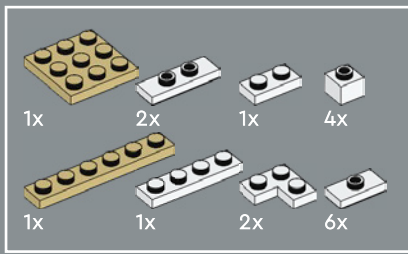

189

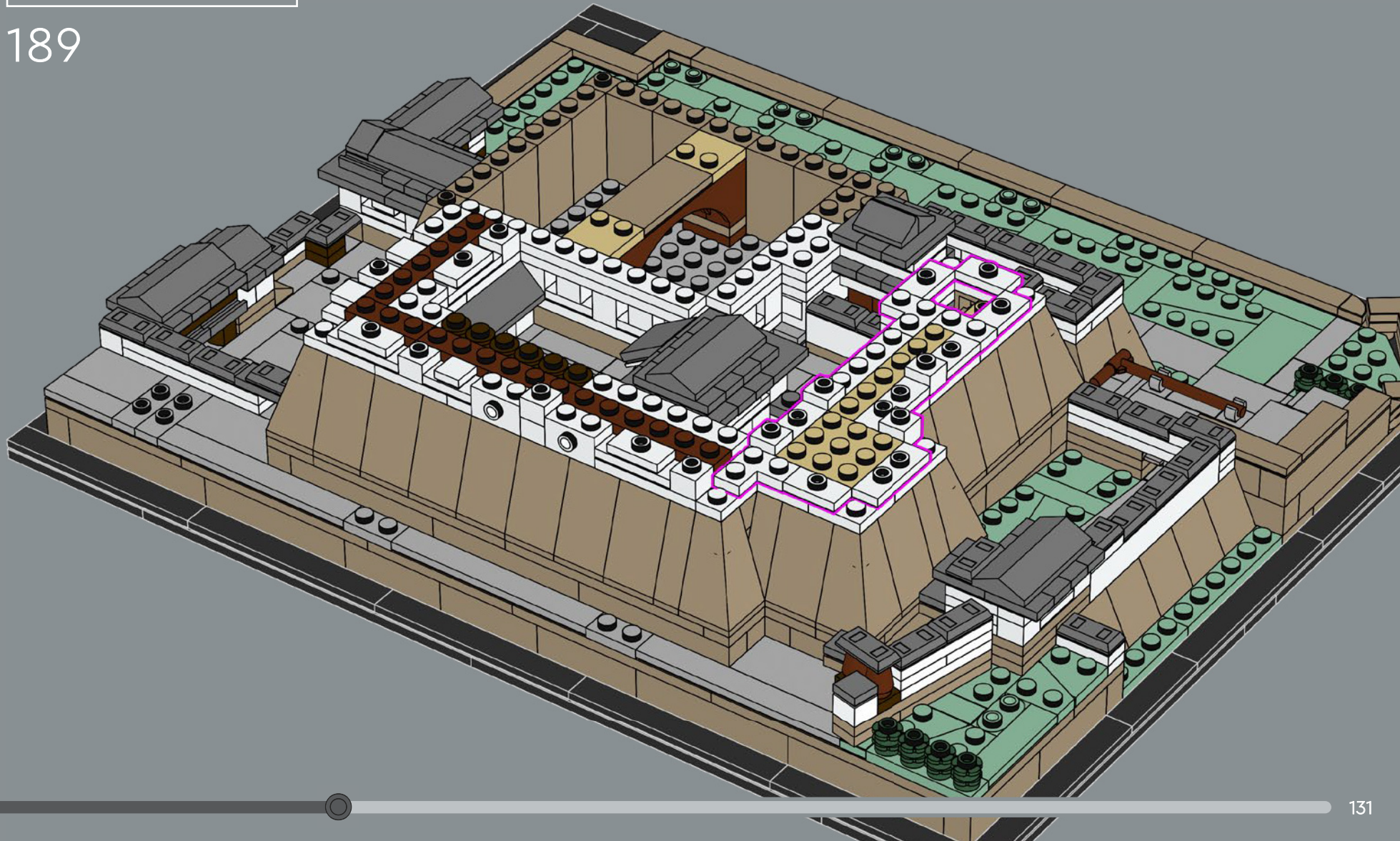

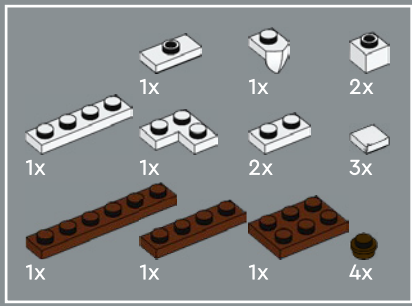

190



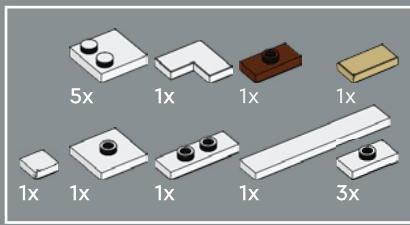

191

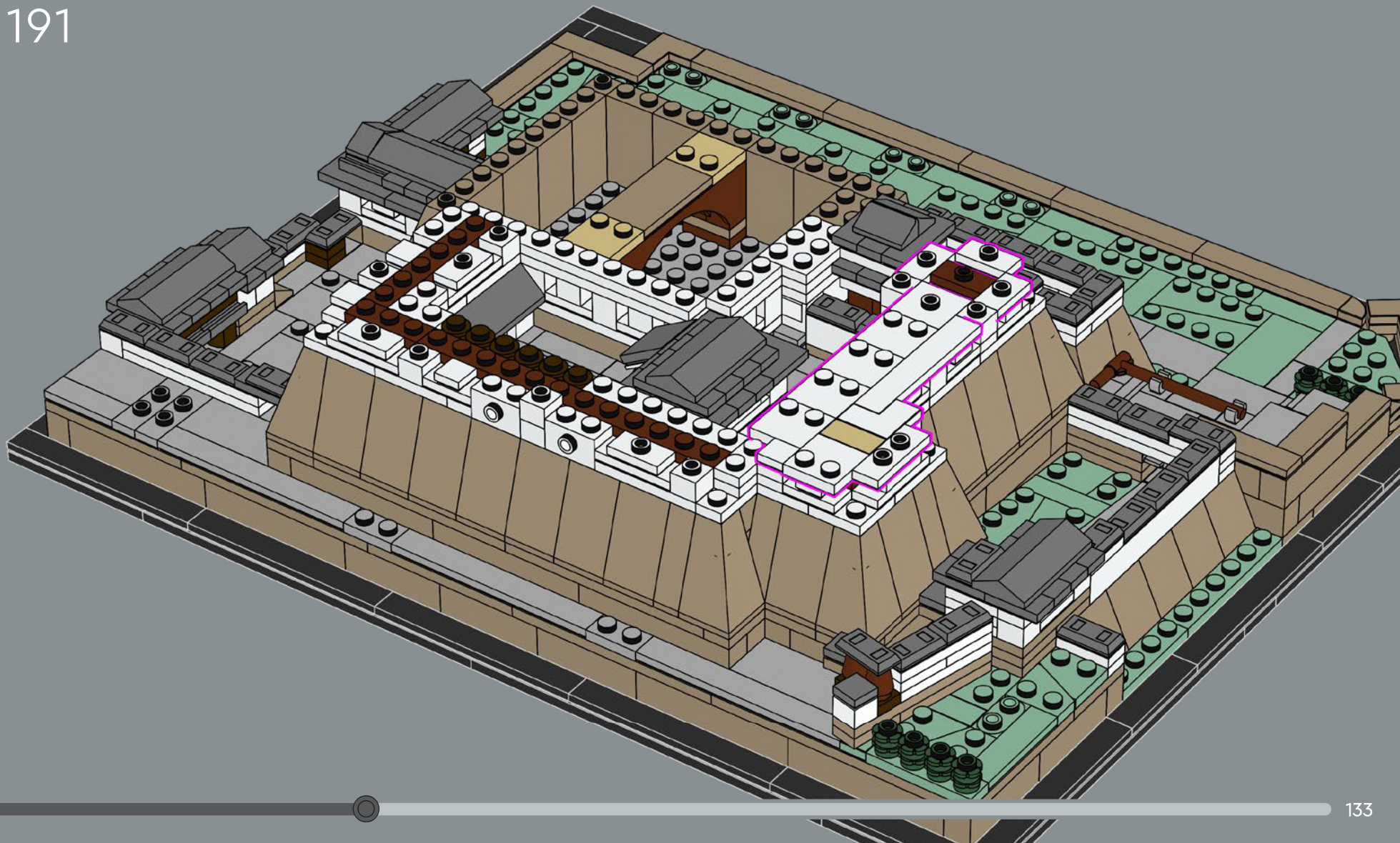

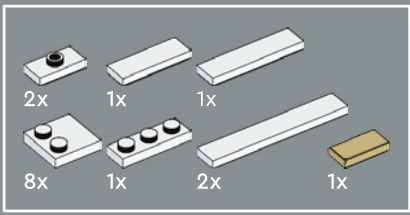

192

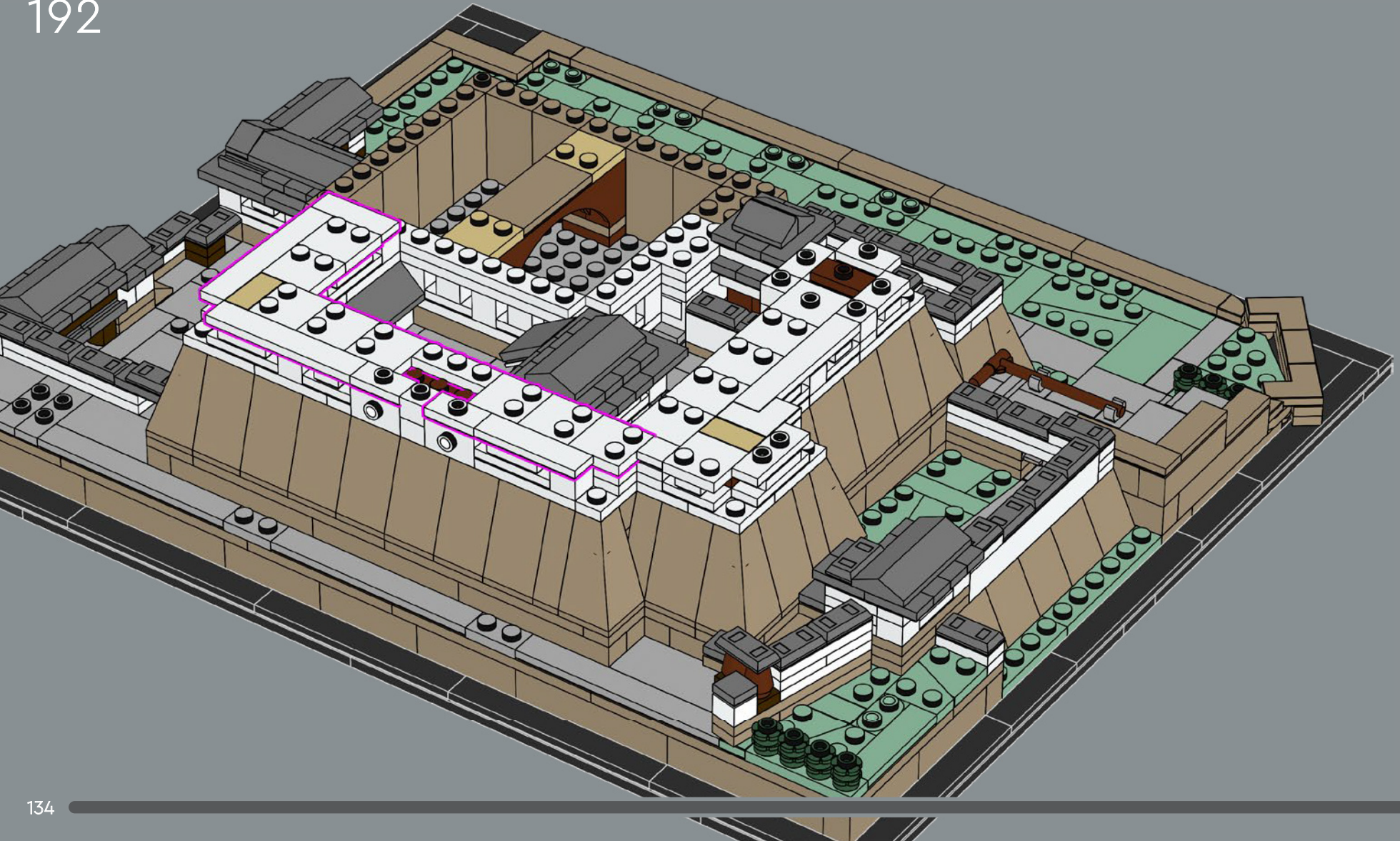

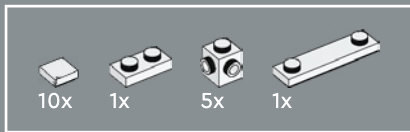

193

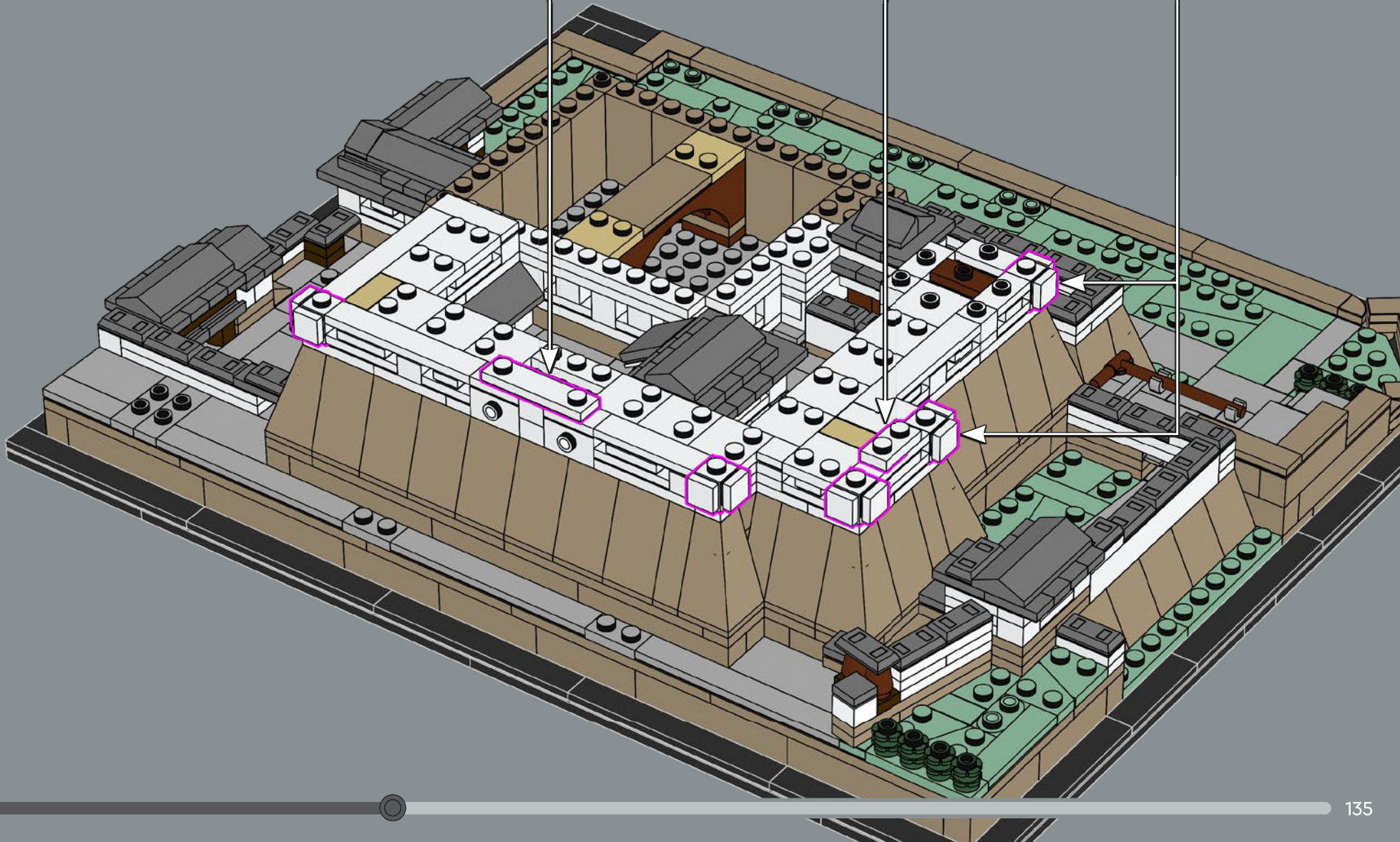
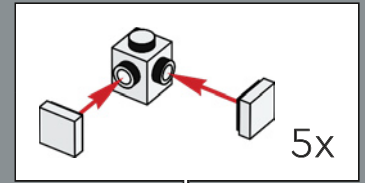
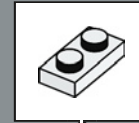
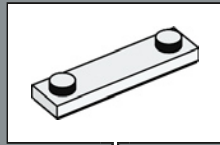

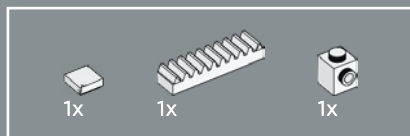

194

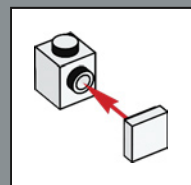
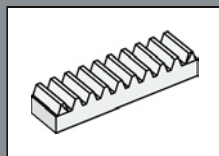

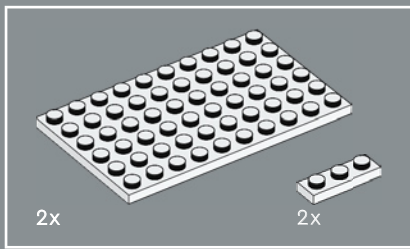

195



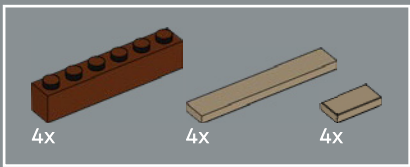

196

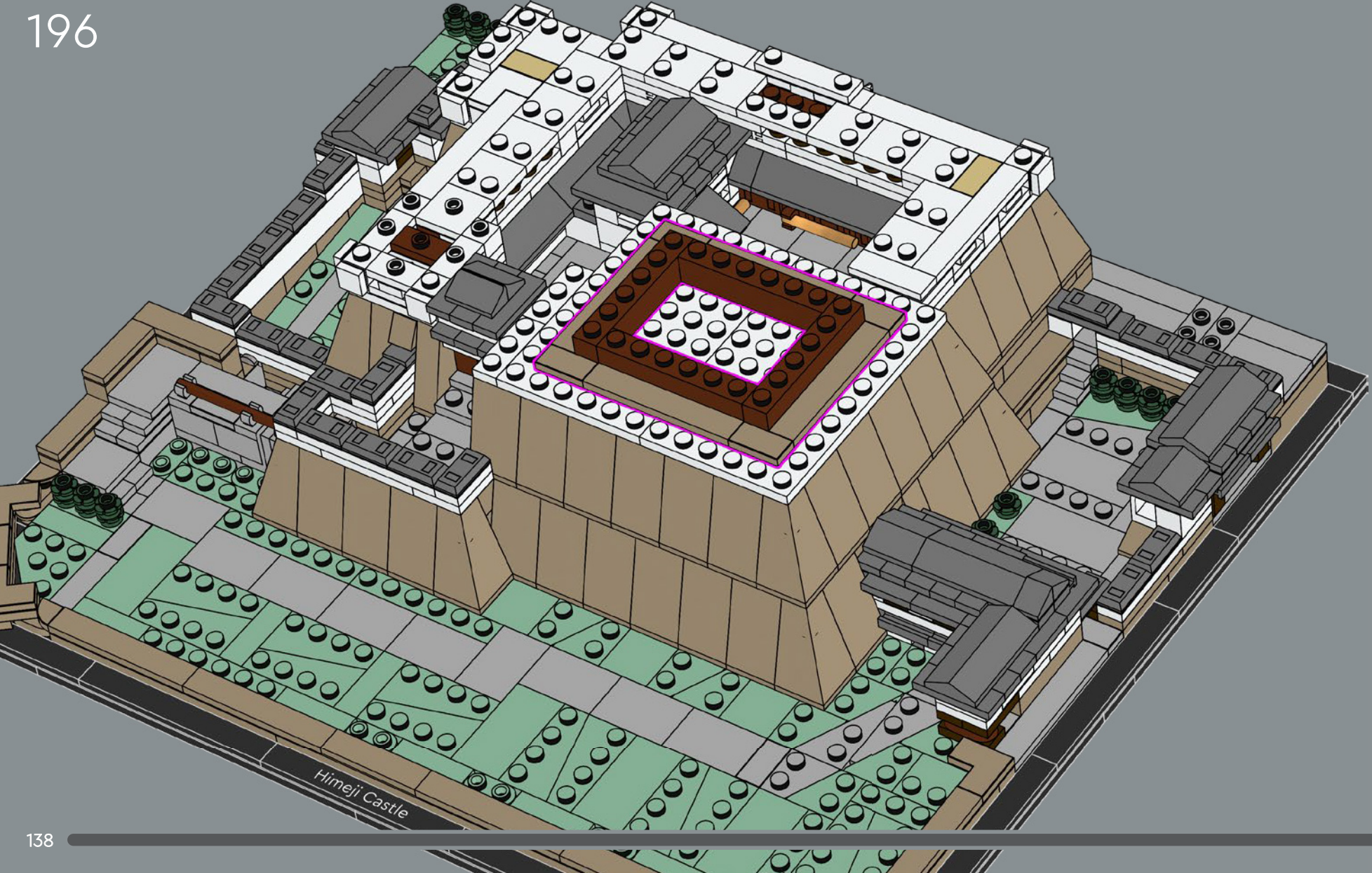

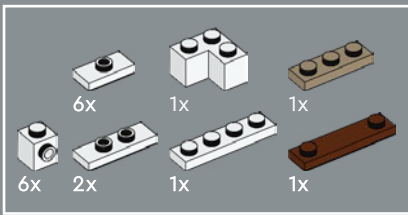

197

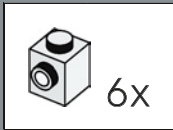
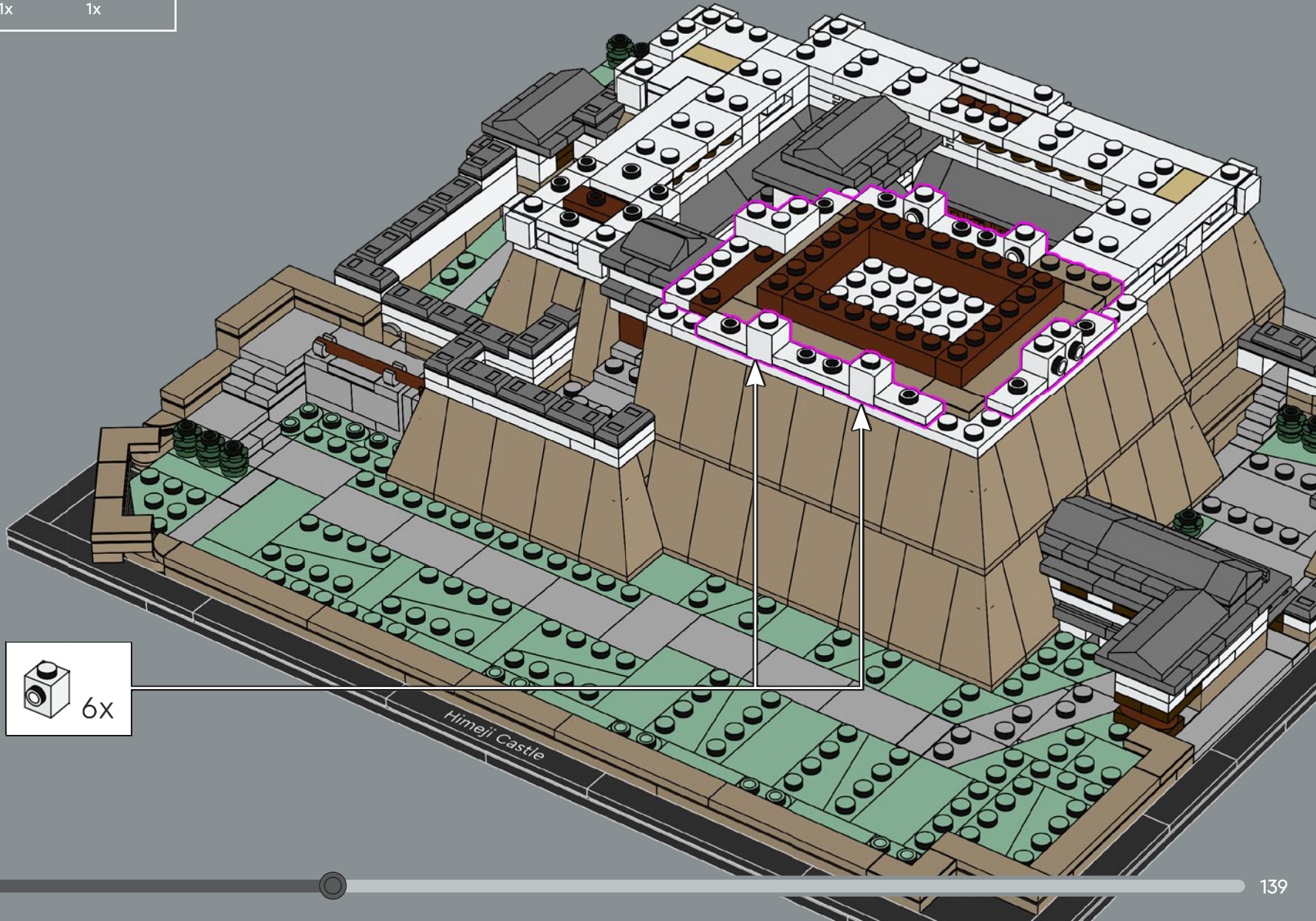

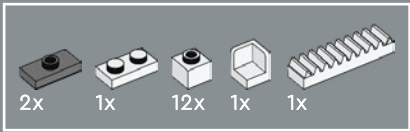

198

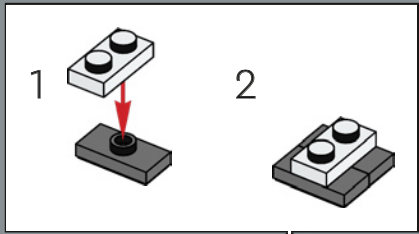

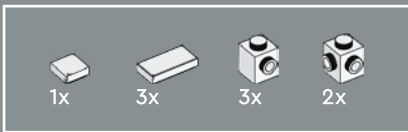

199

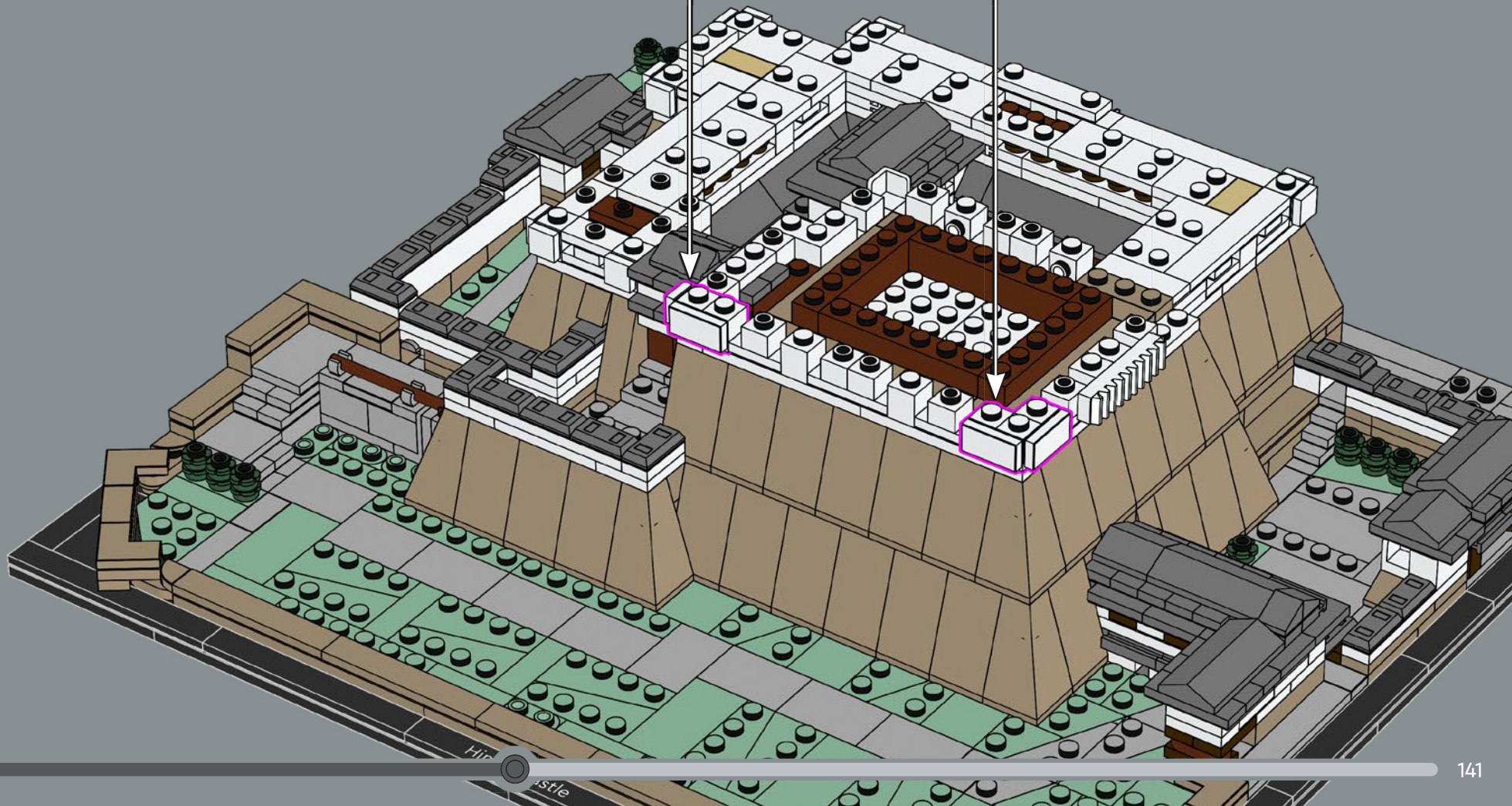
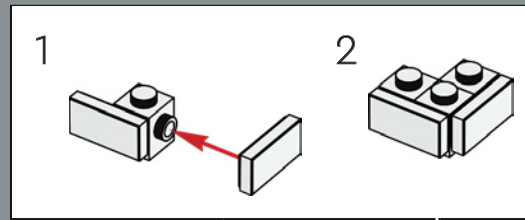
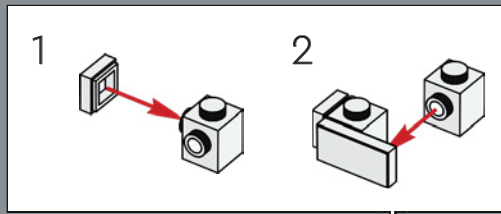

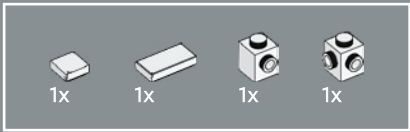

200

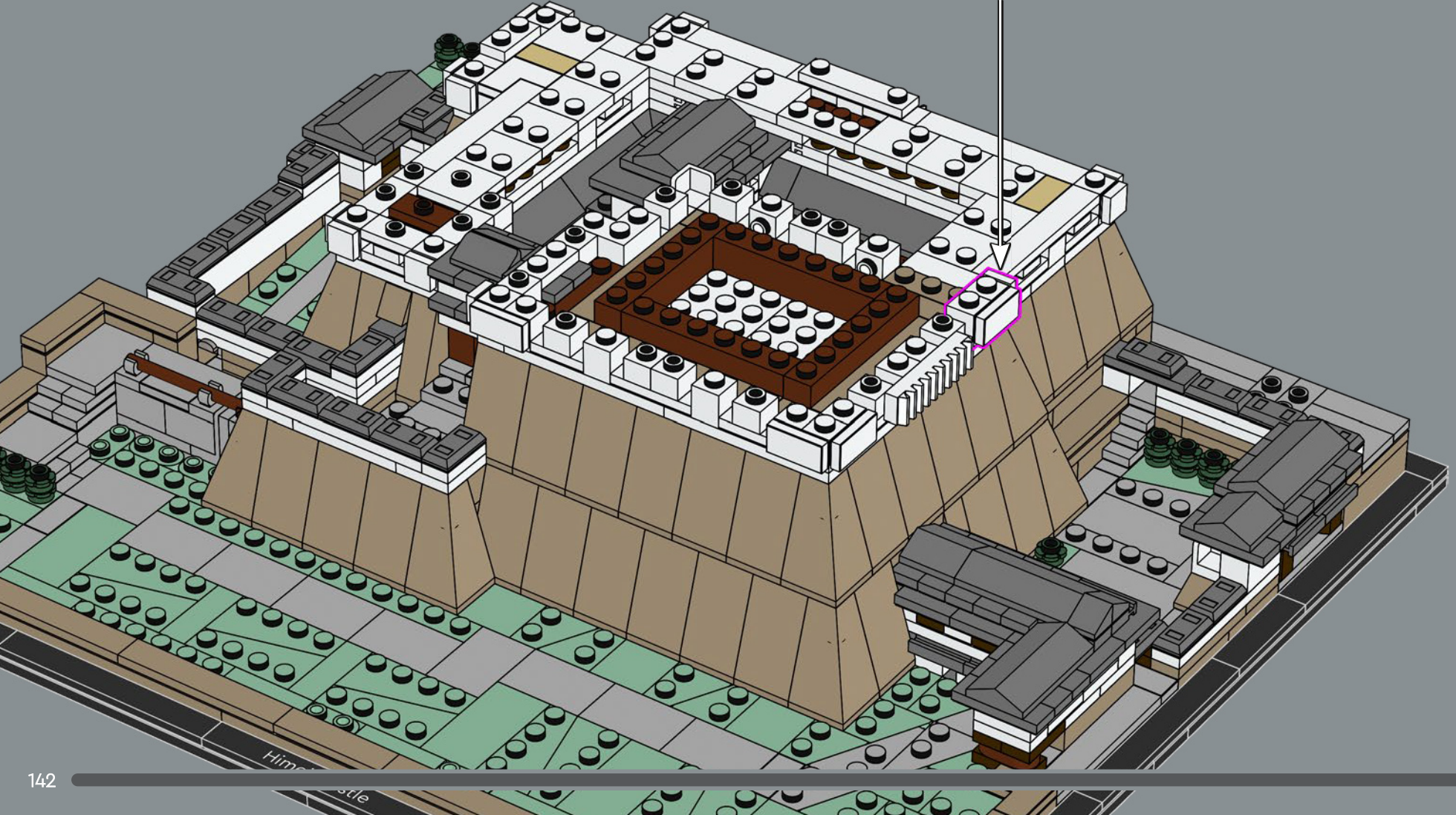
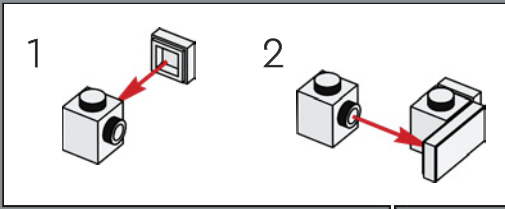

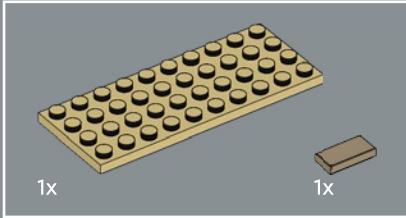
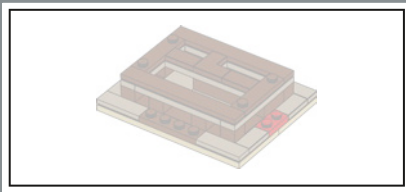

201

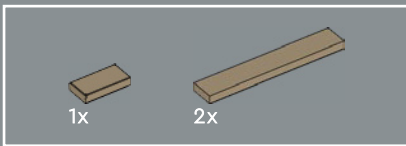
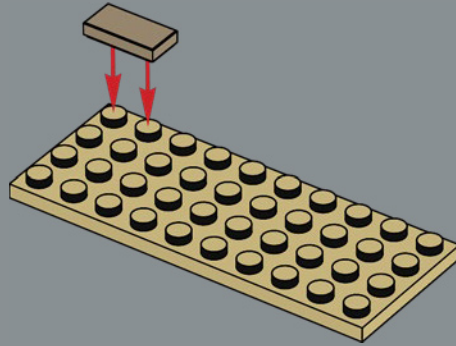

202

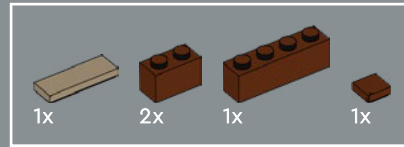
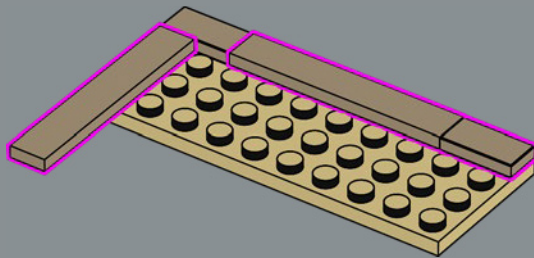

203

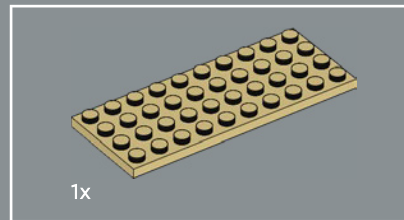
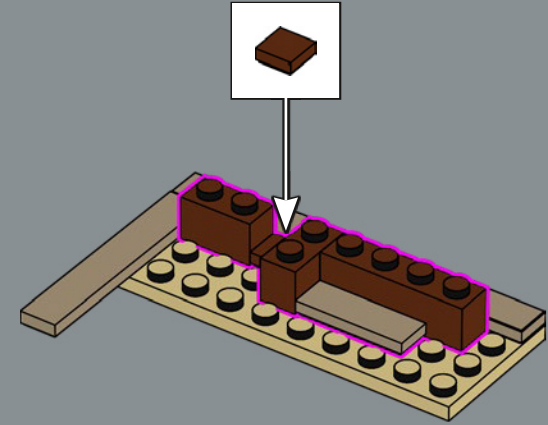

204

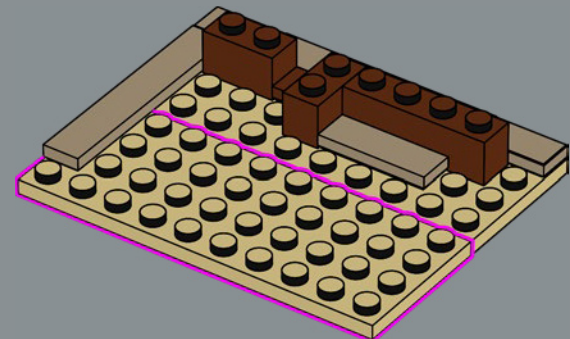

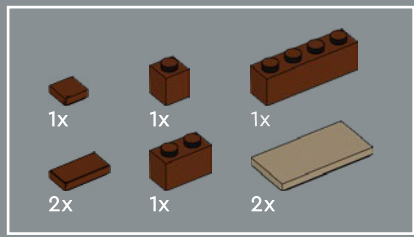

205

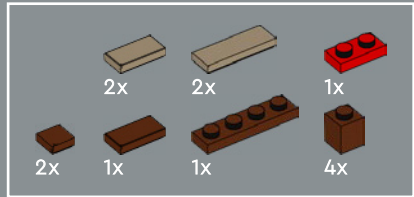
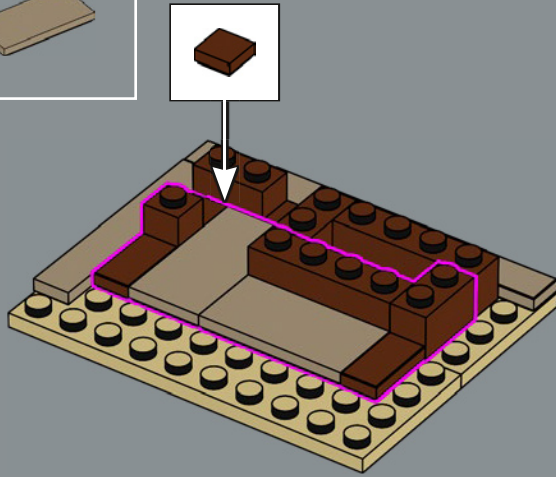

206

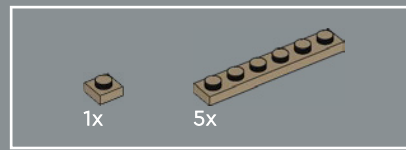
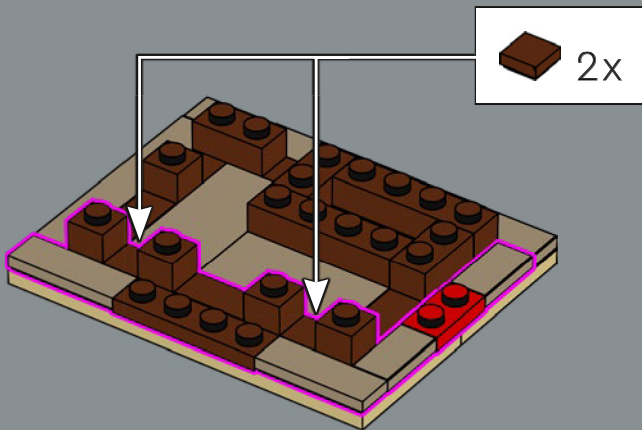

207

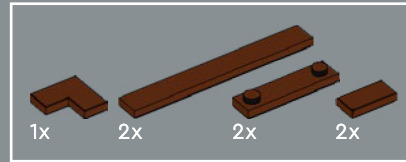
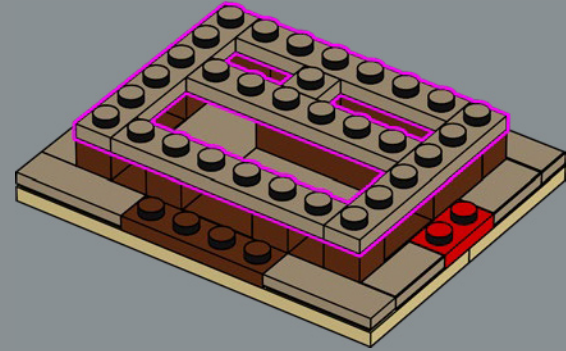

208

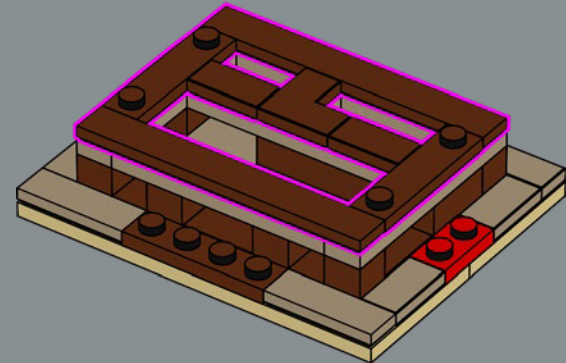

209

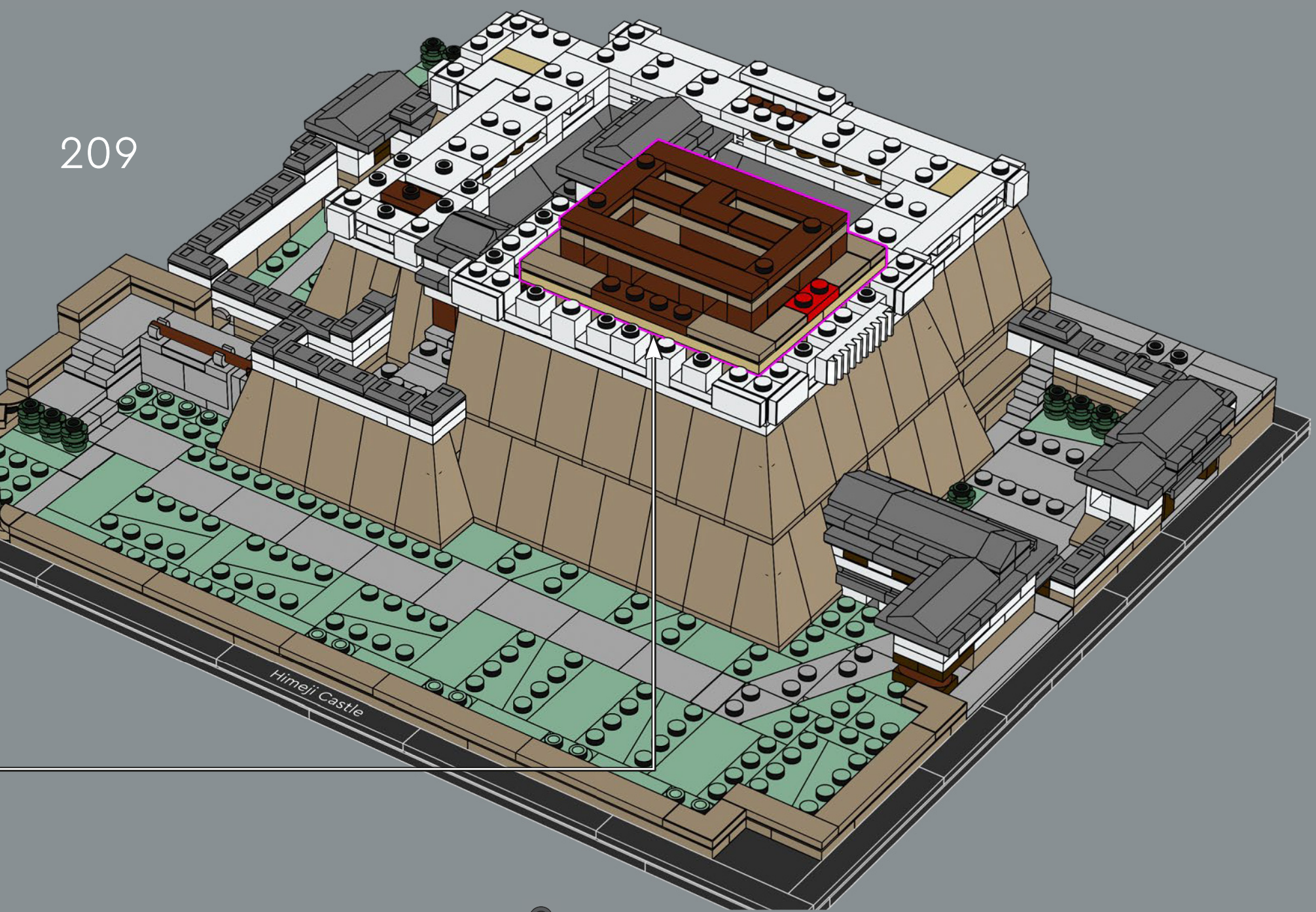

Himeji Castle

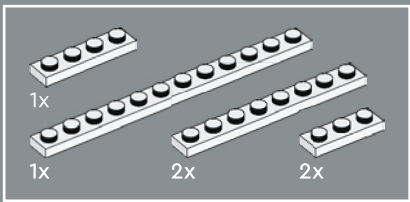

210

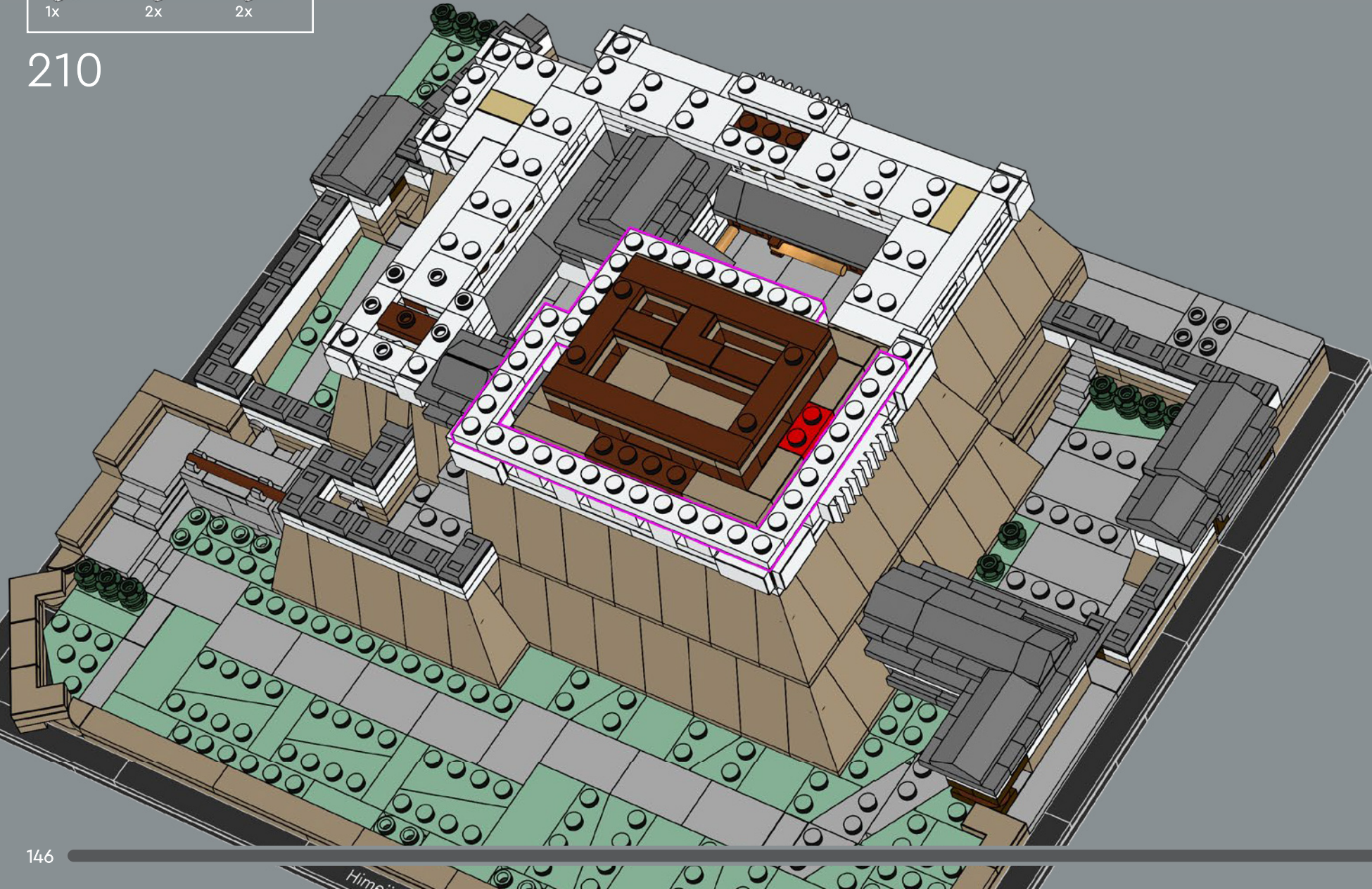

Aunque tuvimos que ceñirnos a ángulos de 90 grados u otros manejables para este set, conservamos algunas de las líneas asimétricas como muestra de respeto hacia el castillo original.

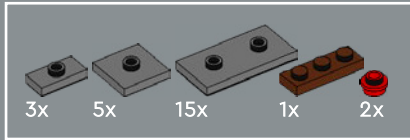

211

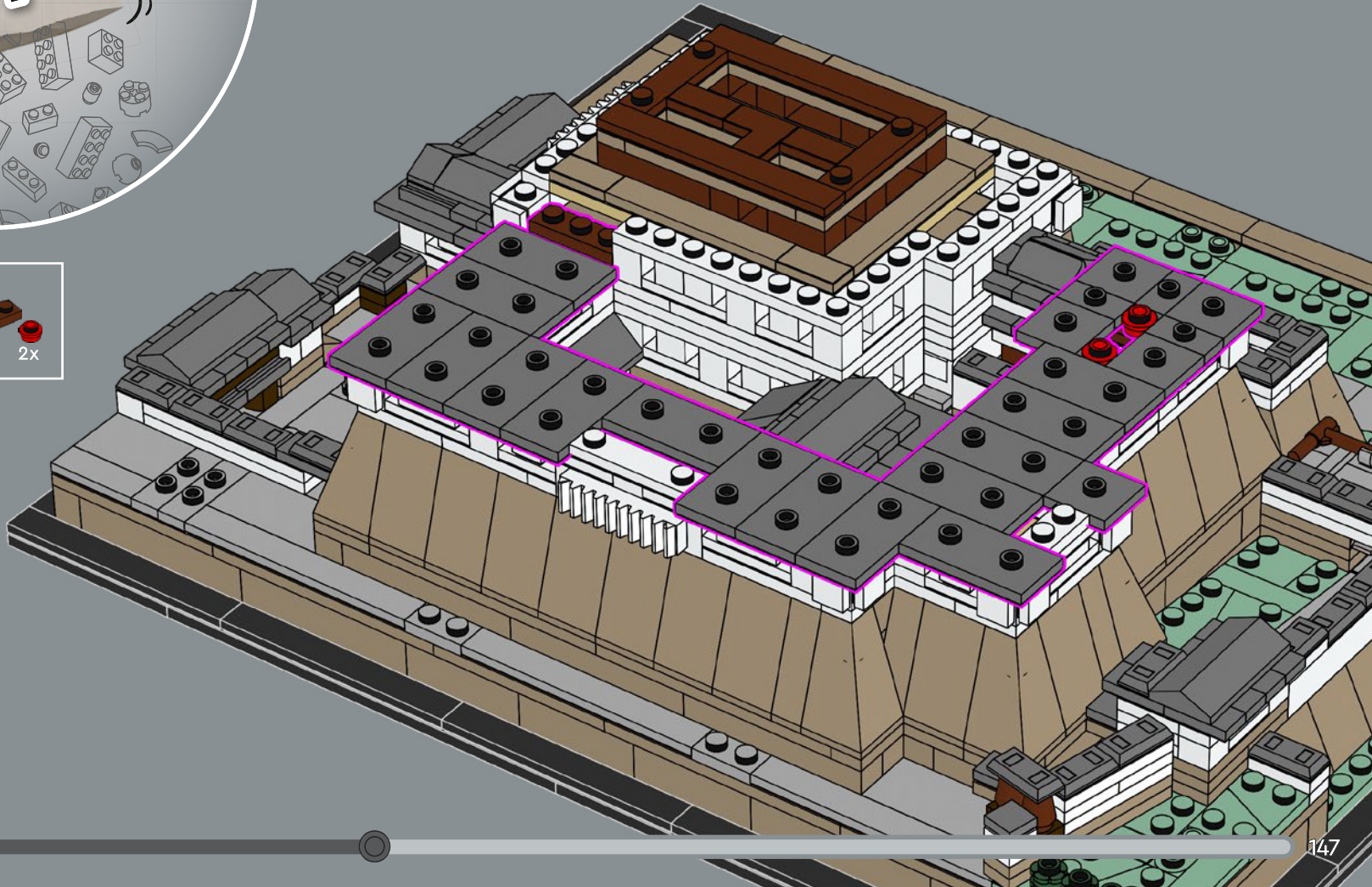

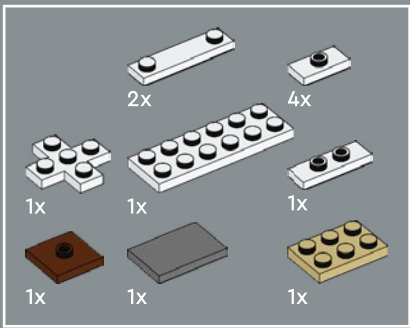

212

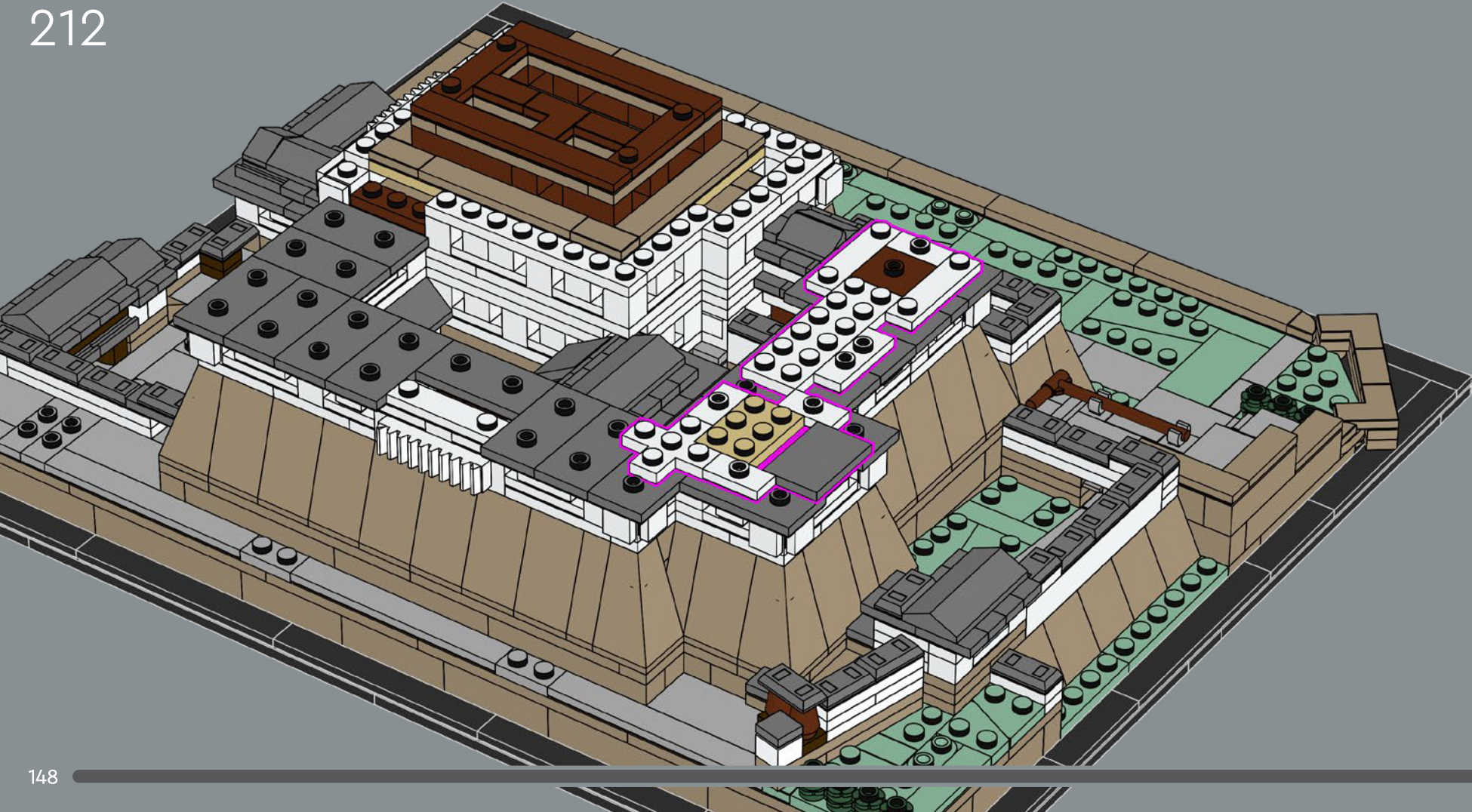

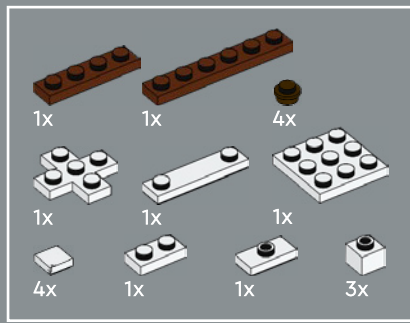

213

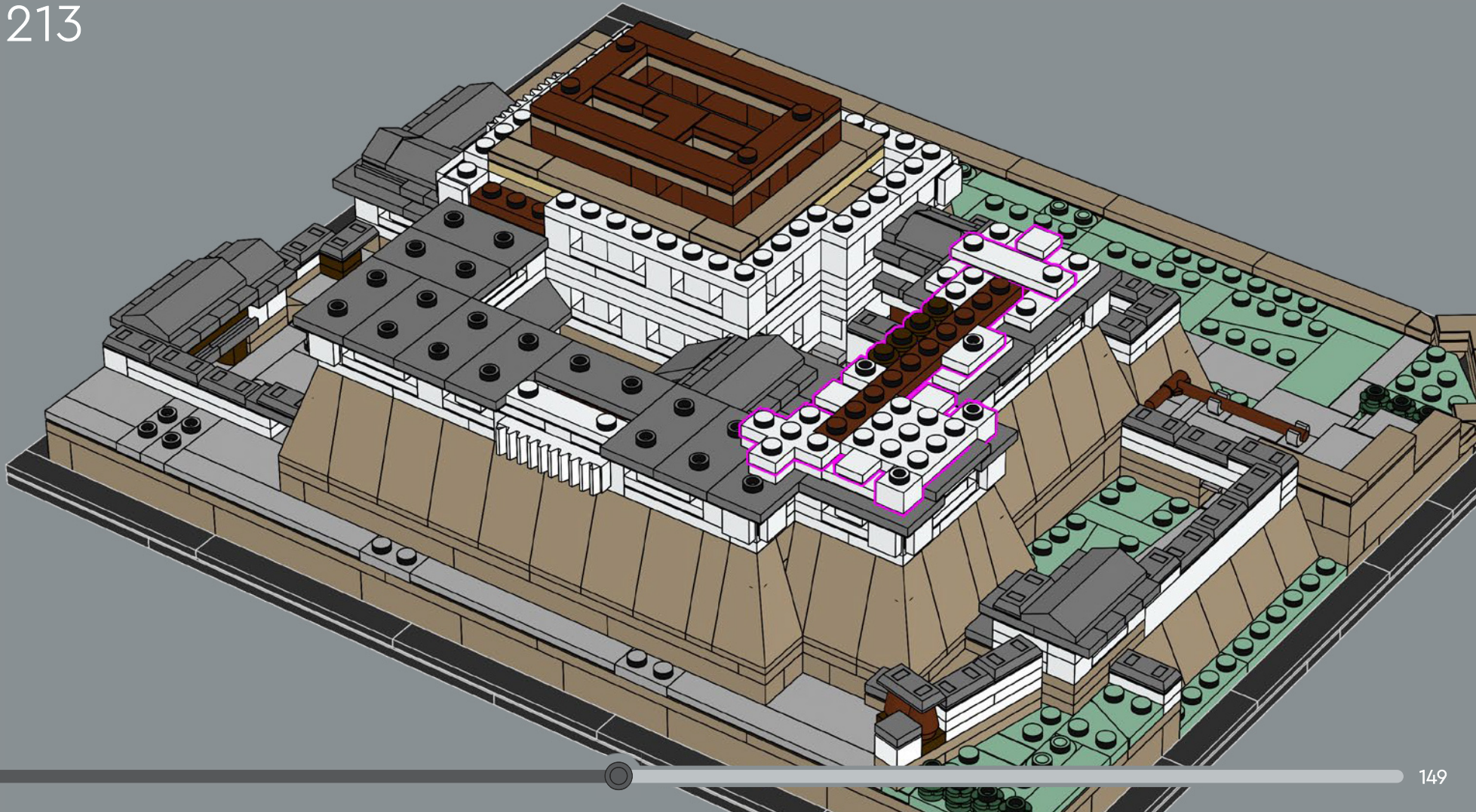

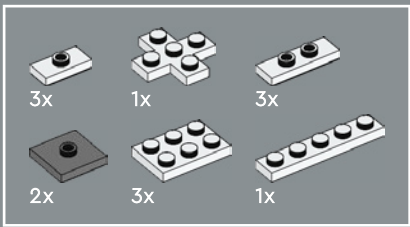

214

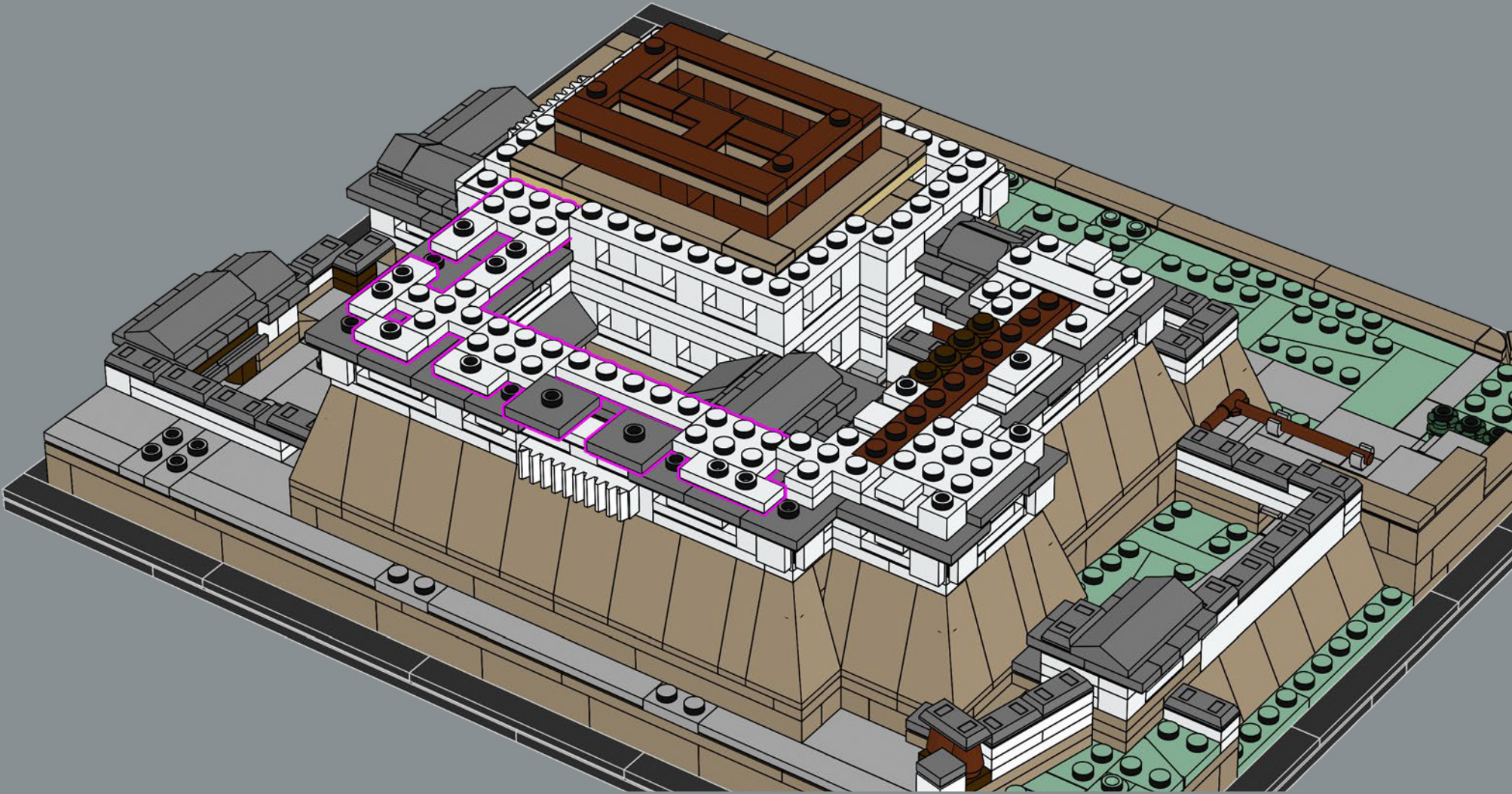

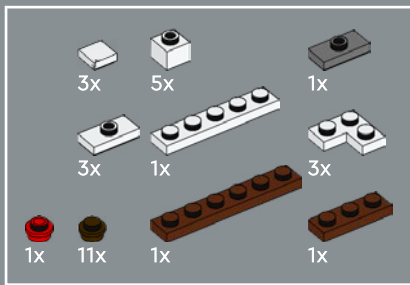

215

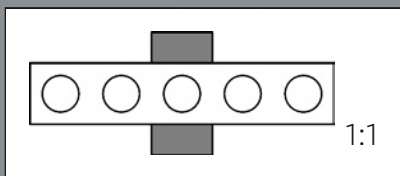
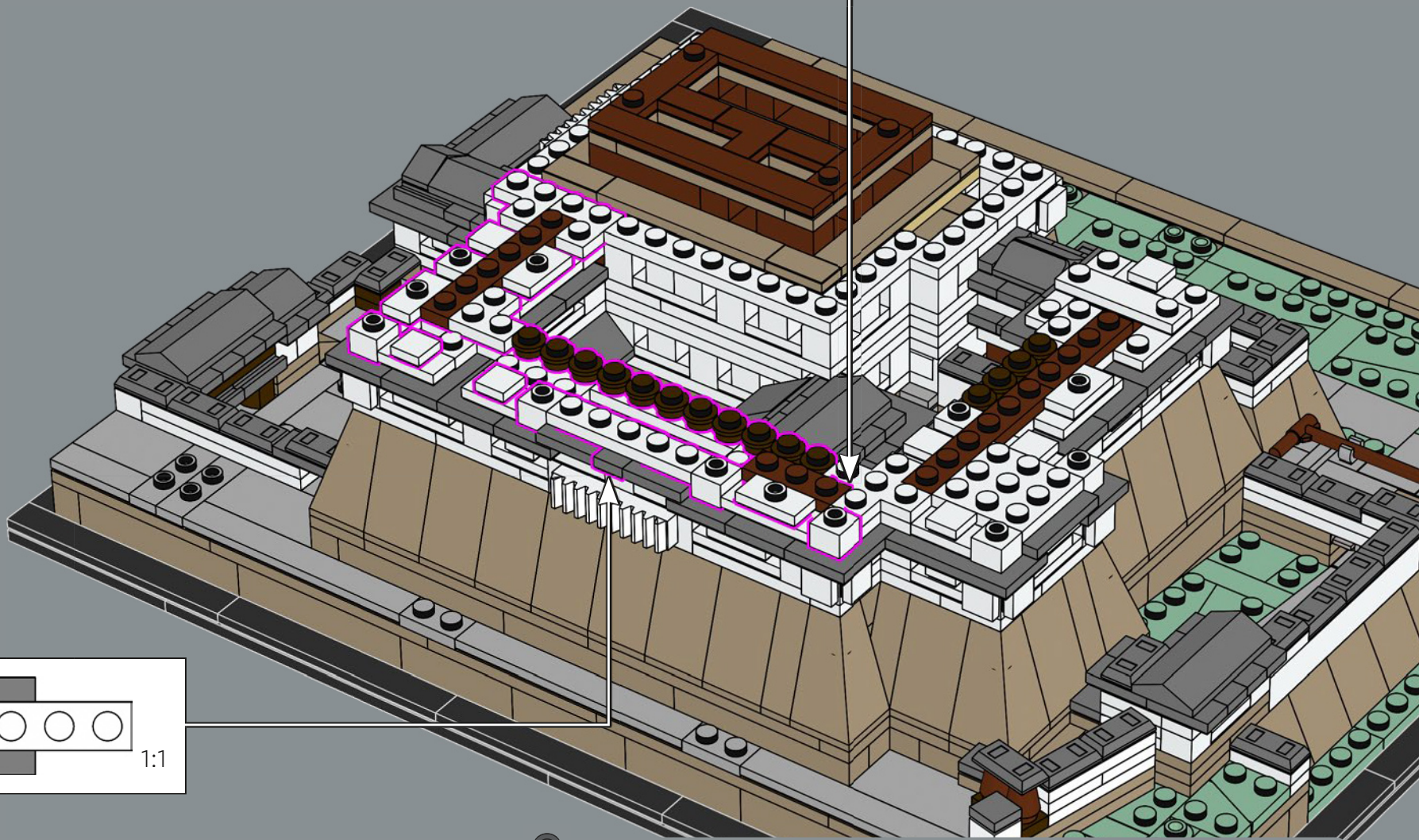
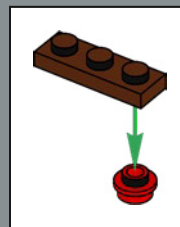

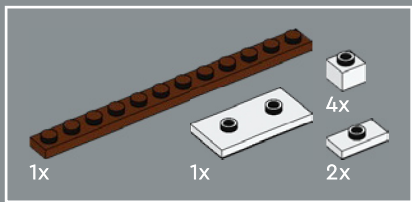

216

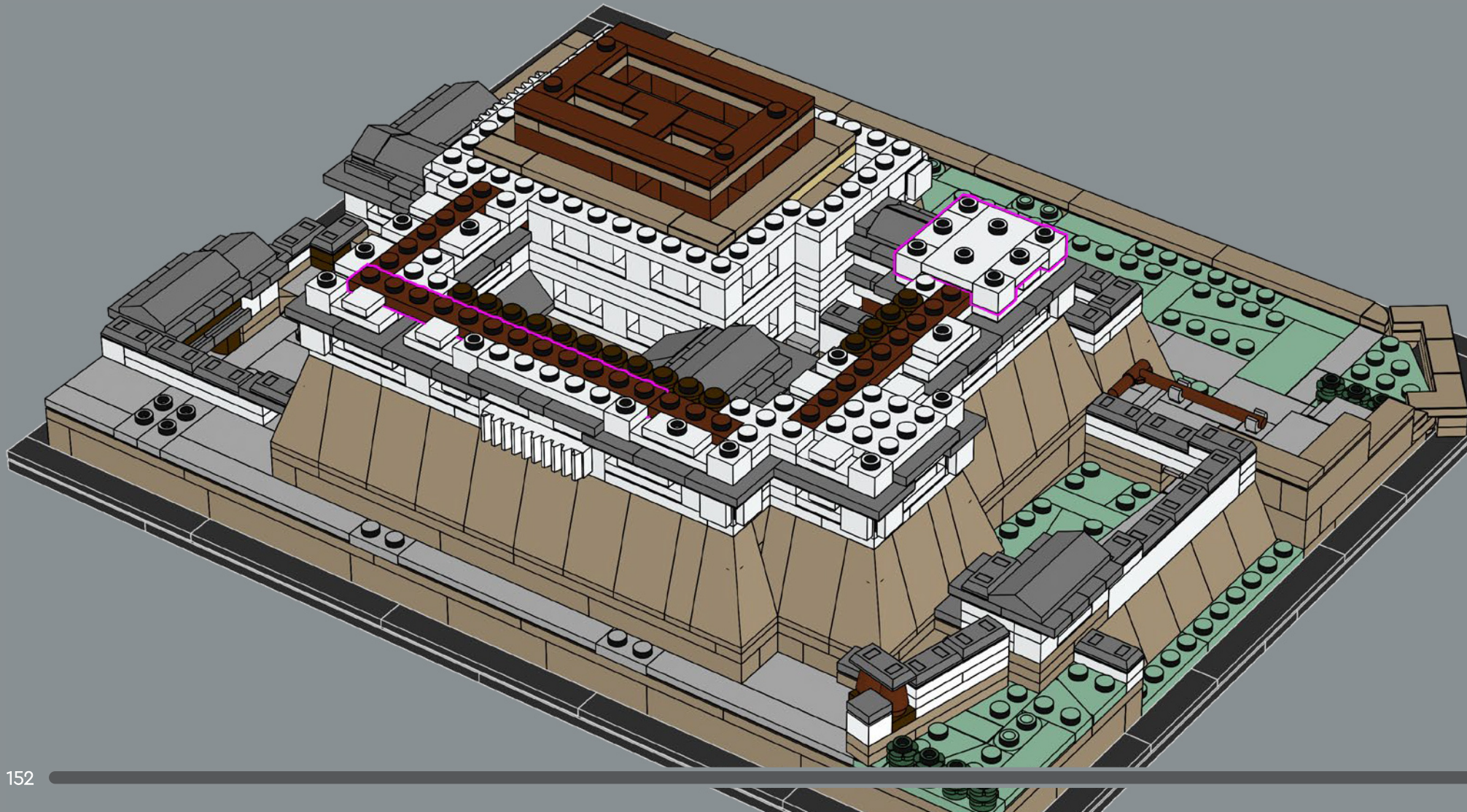

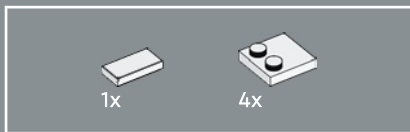

217

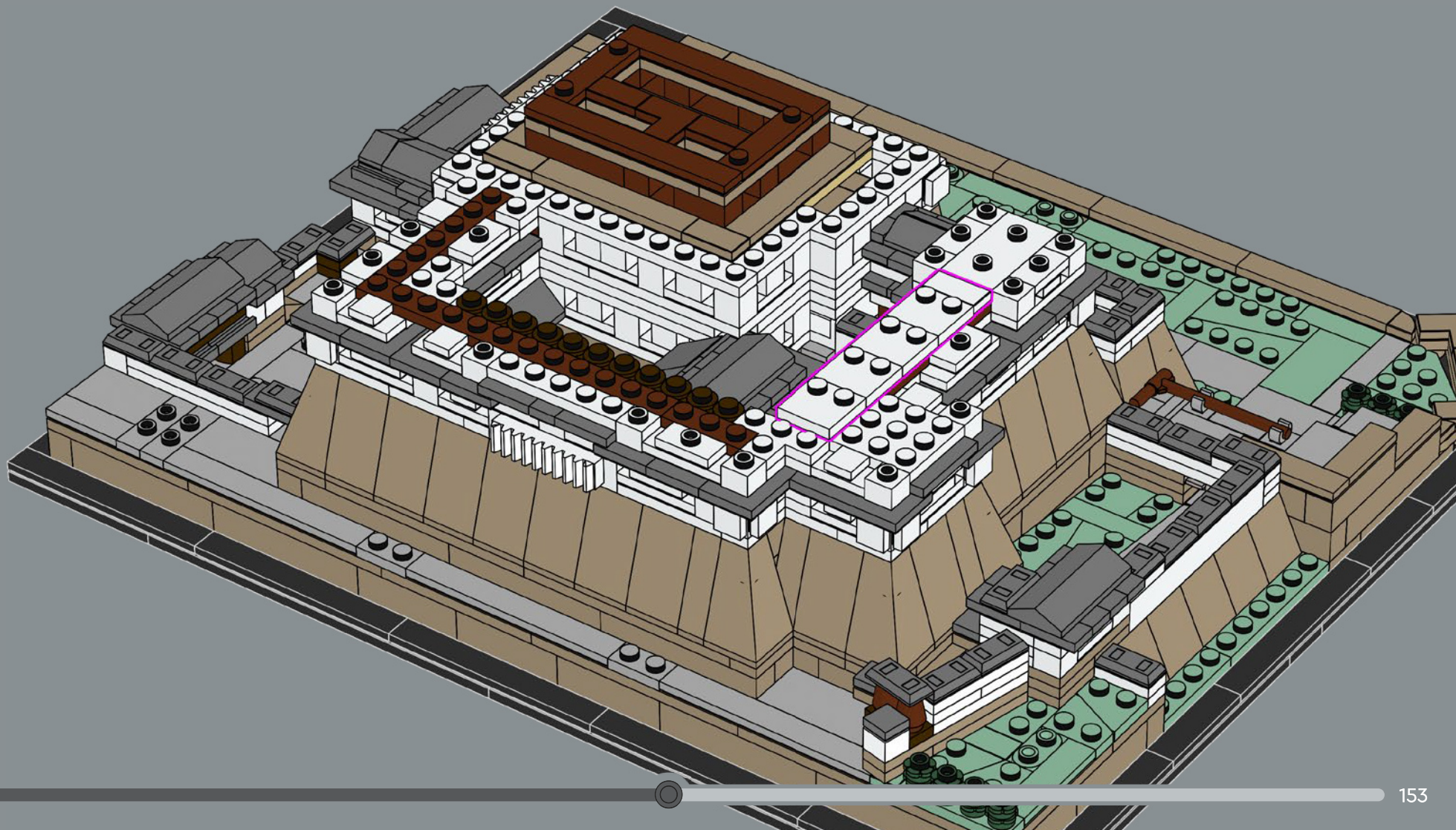

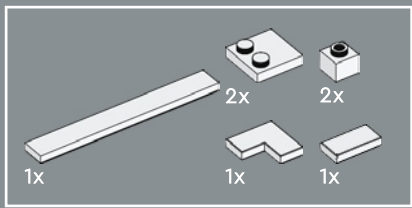

218

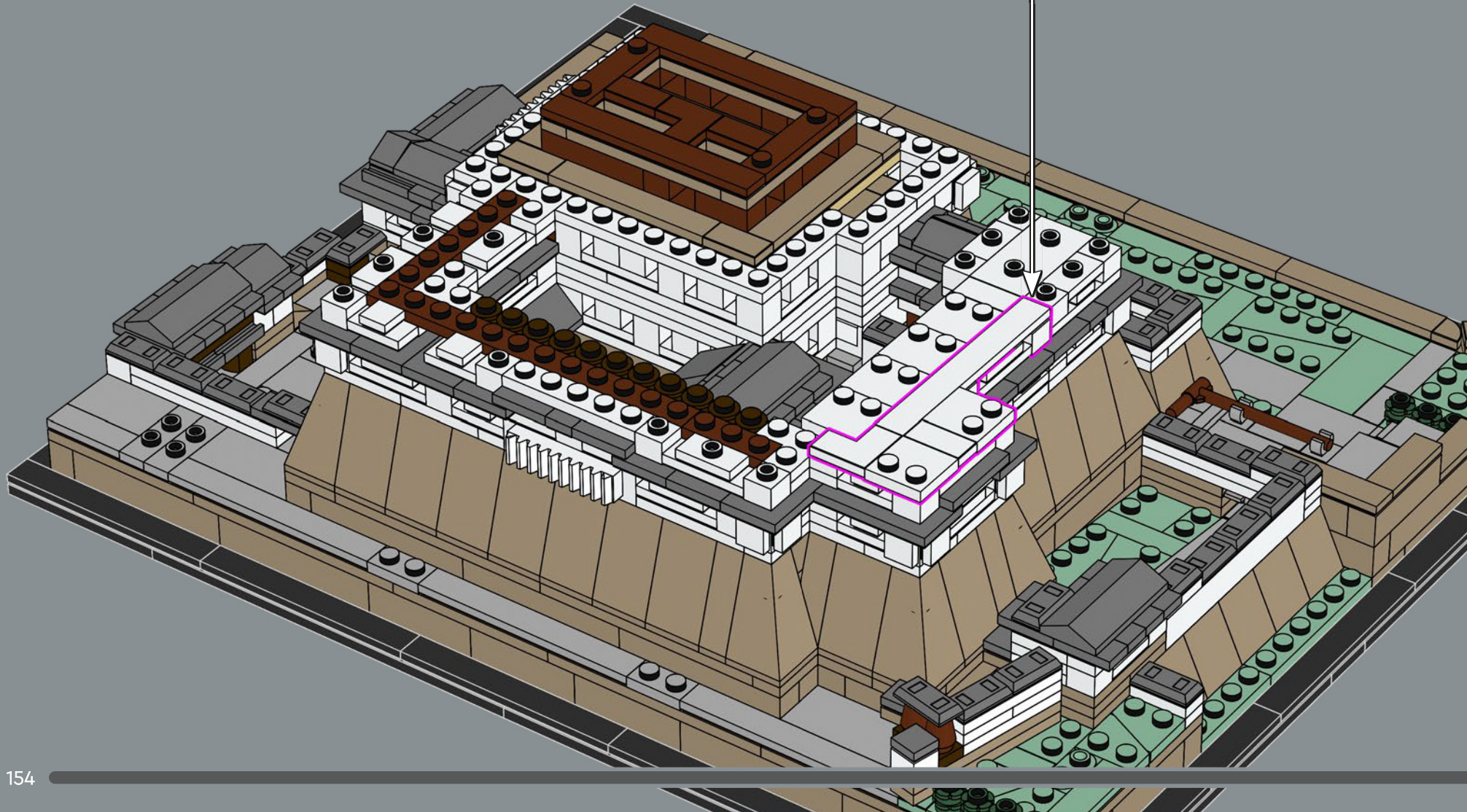
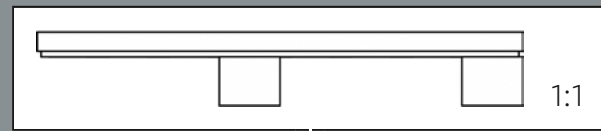

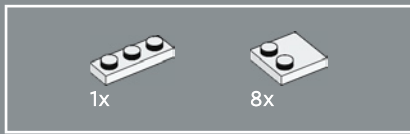

219

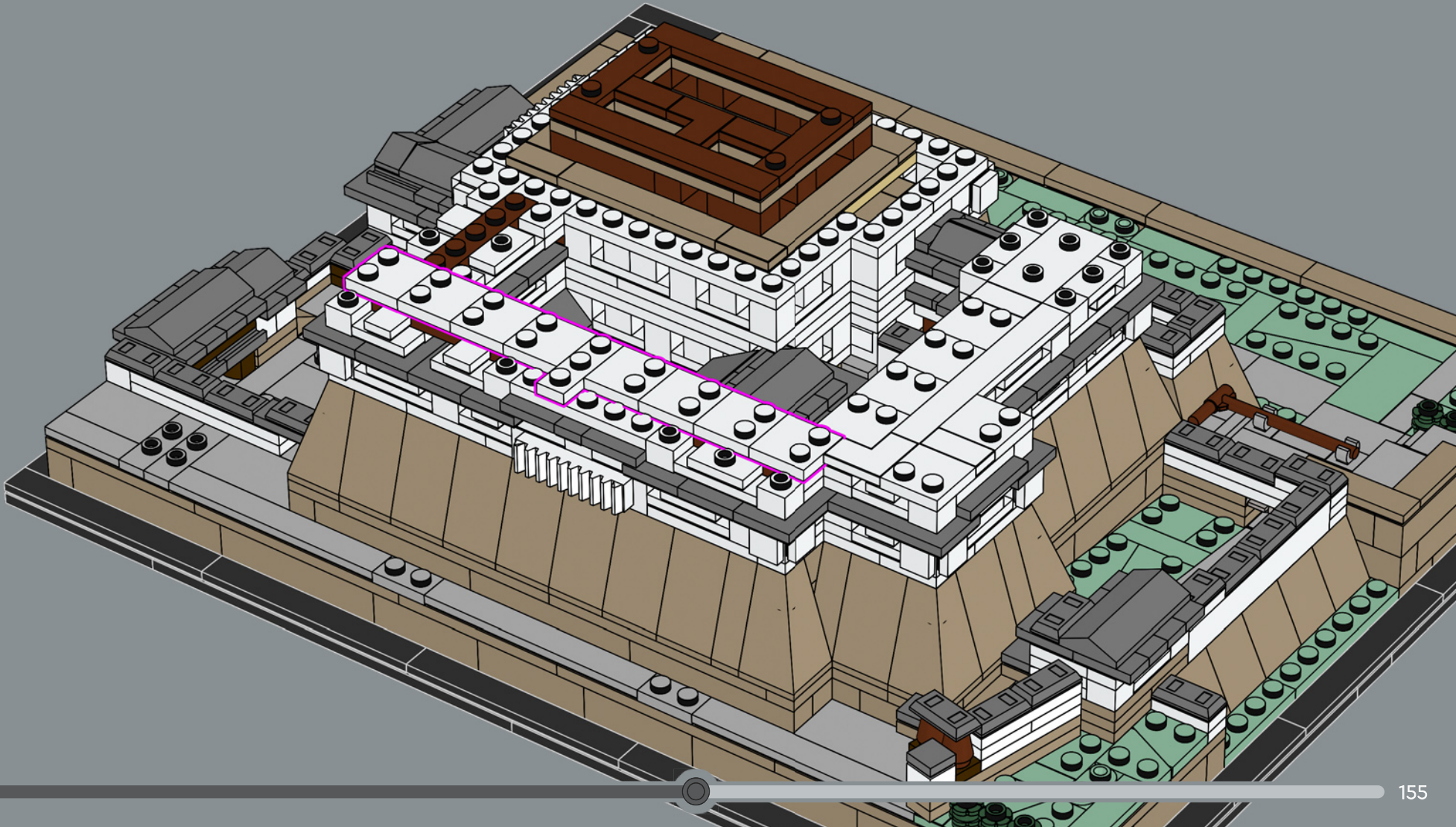

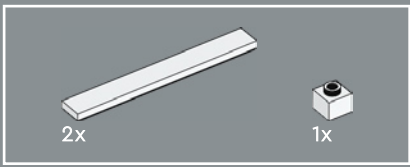

220

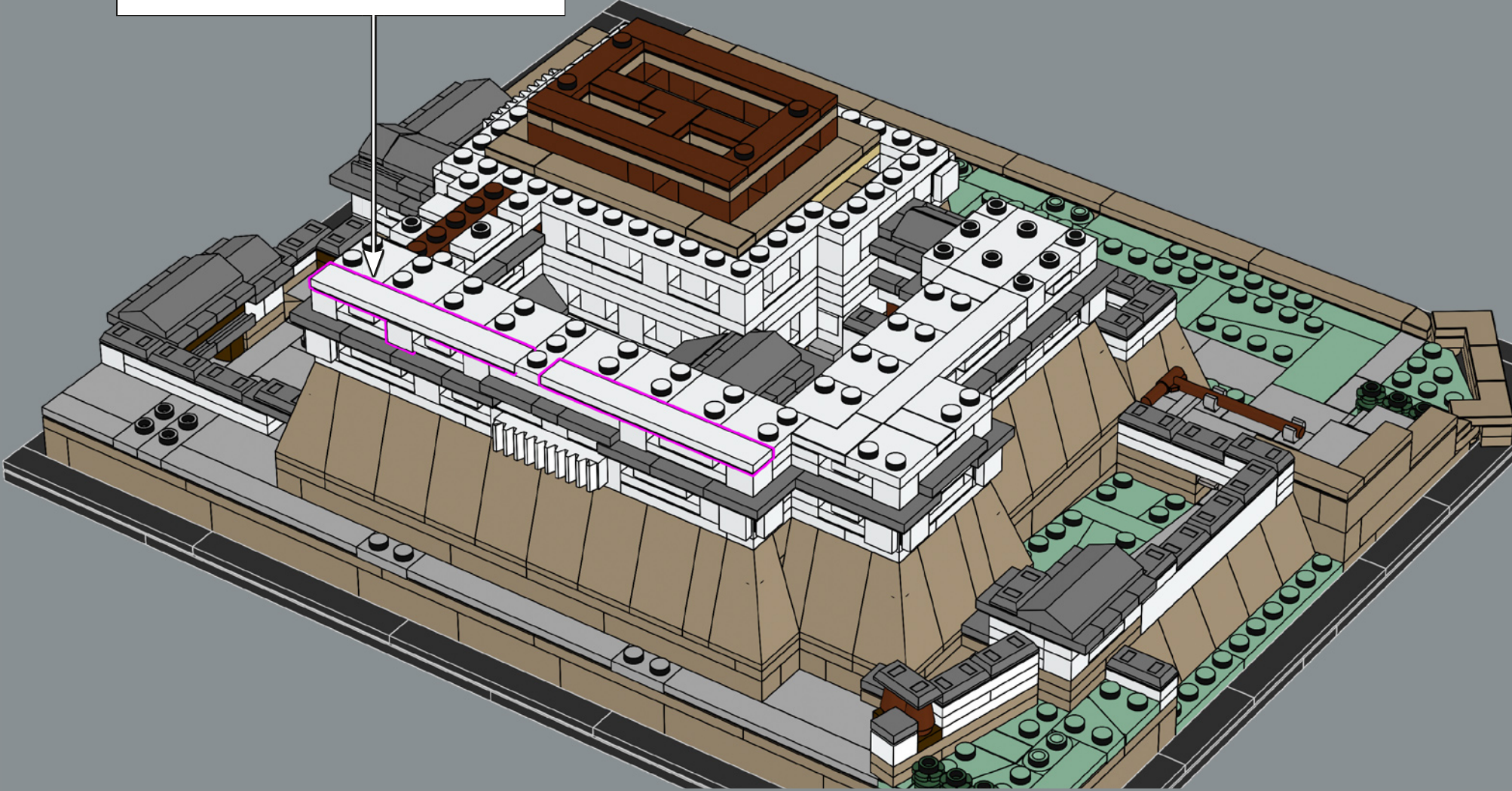
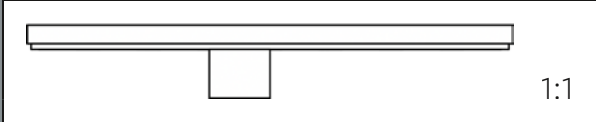

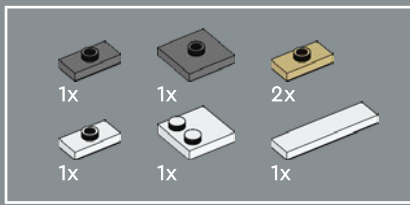

221

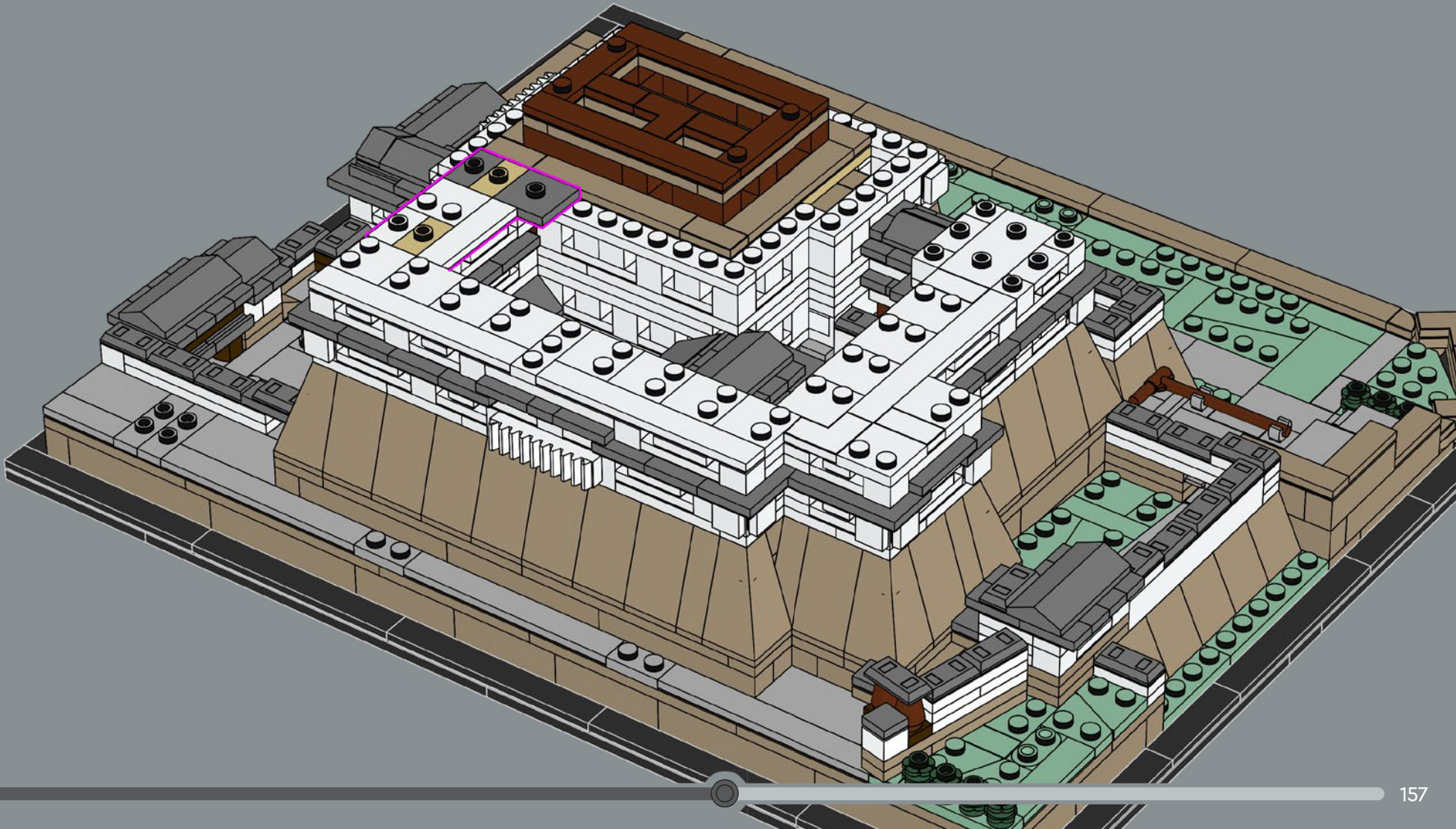

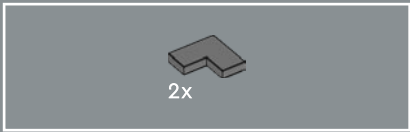

222

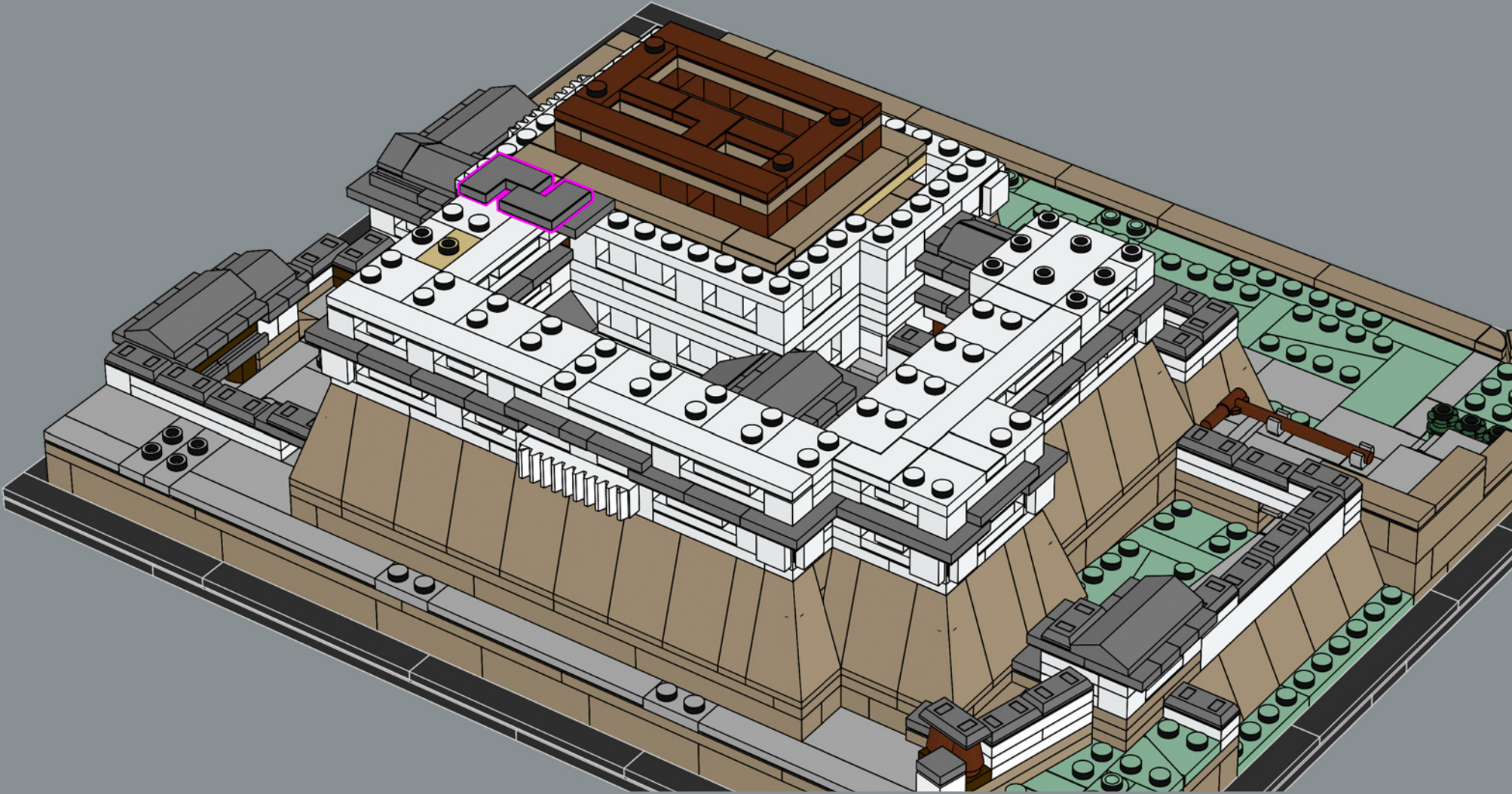

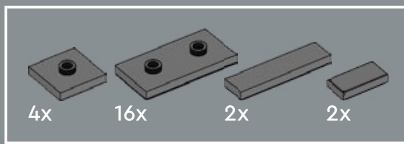

223

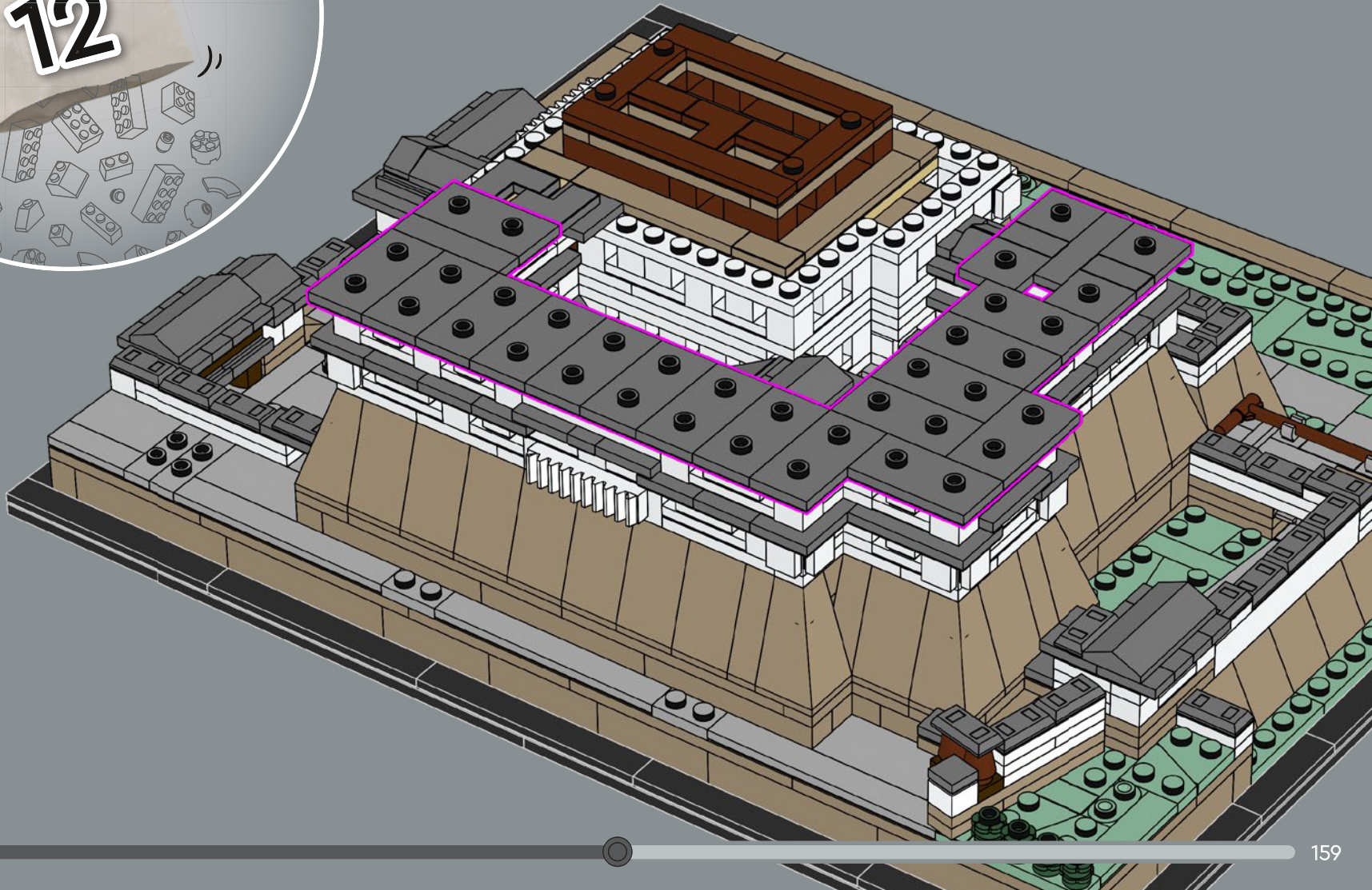

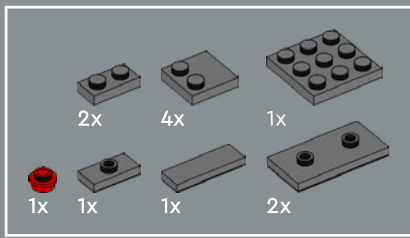

224

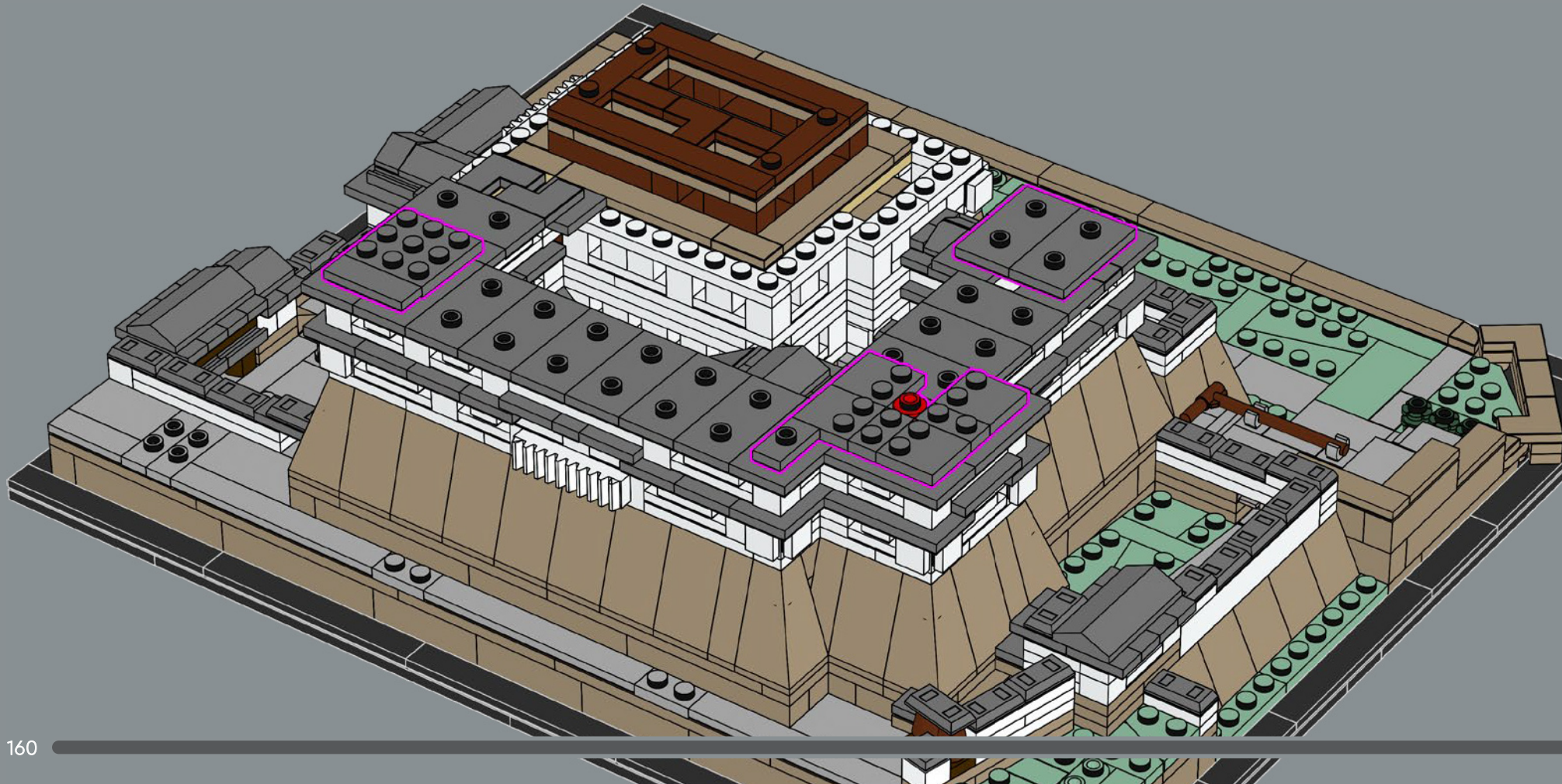

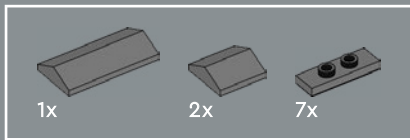

225

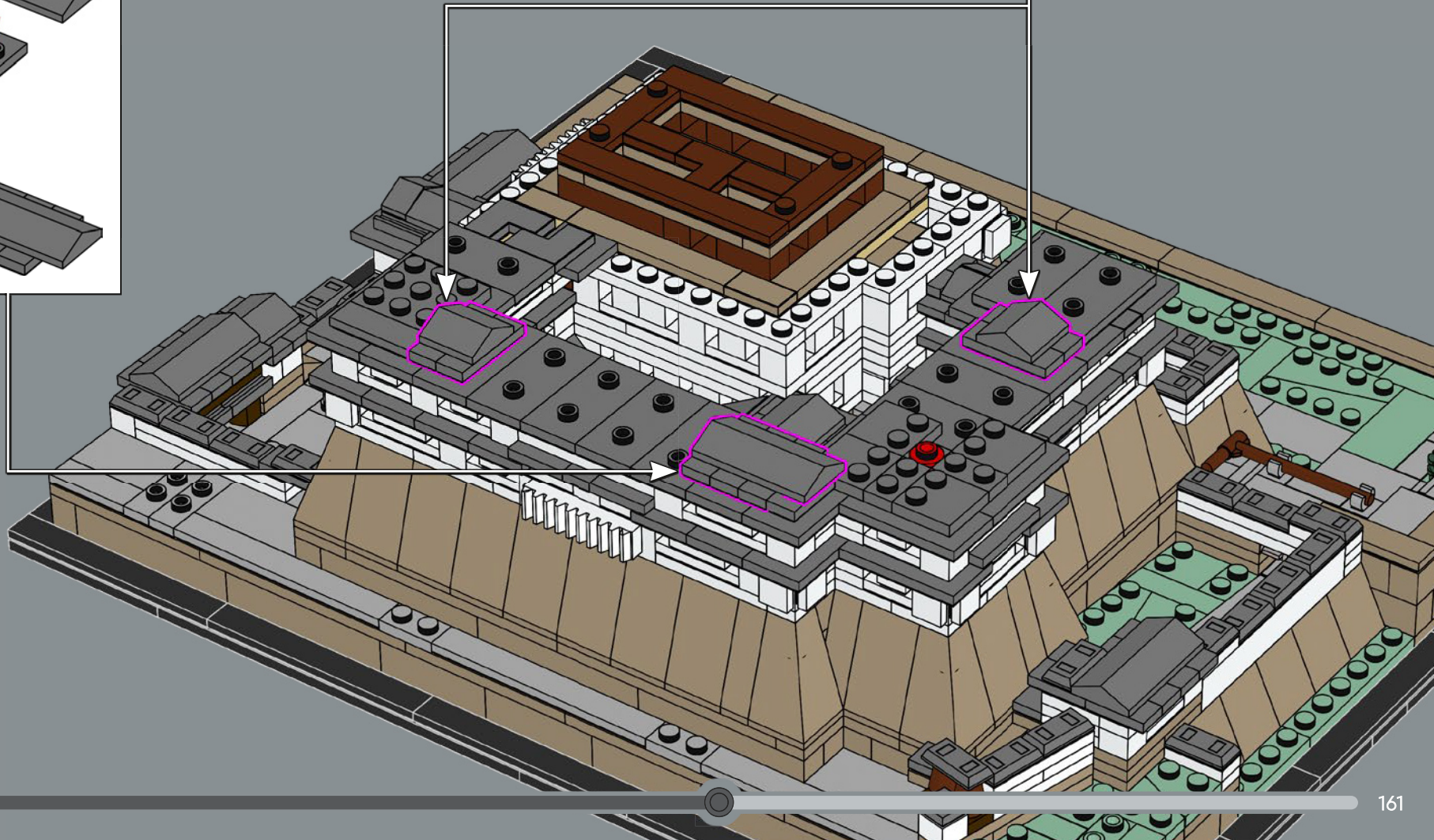
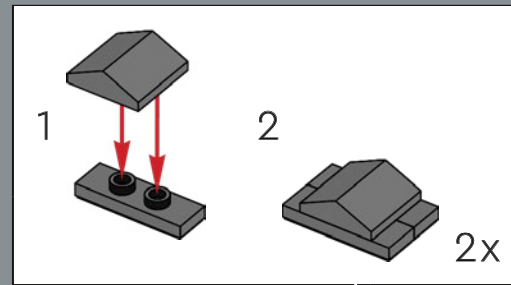
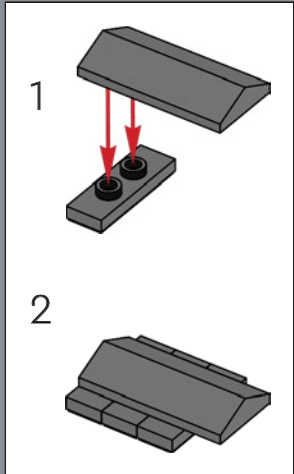

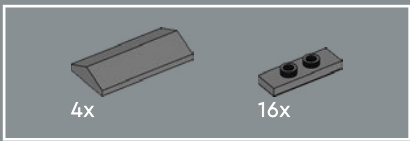

226

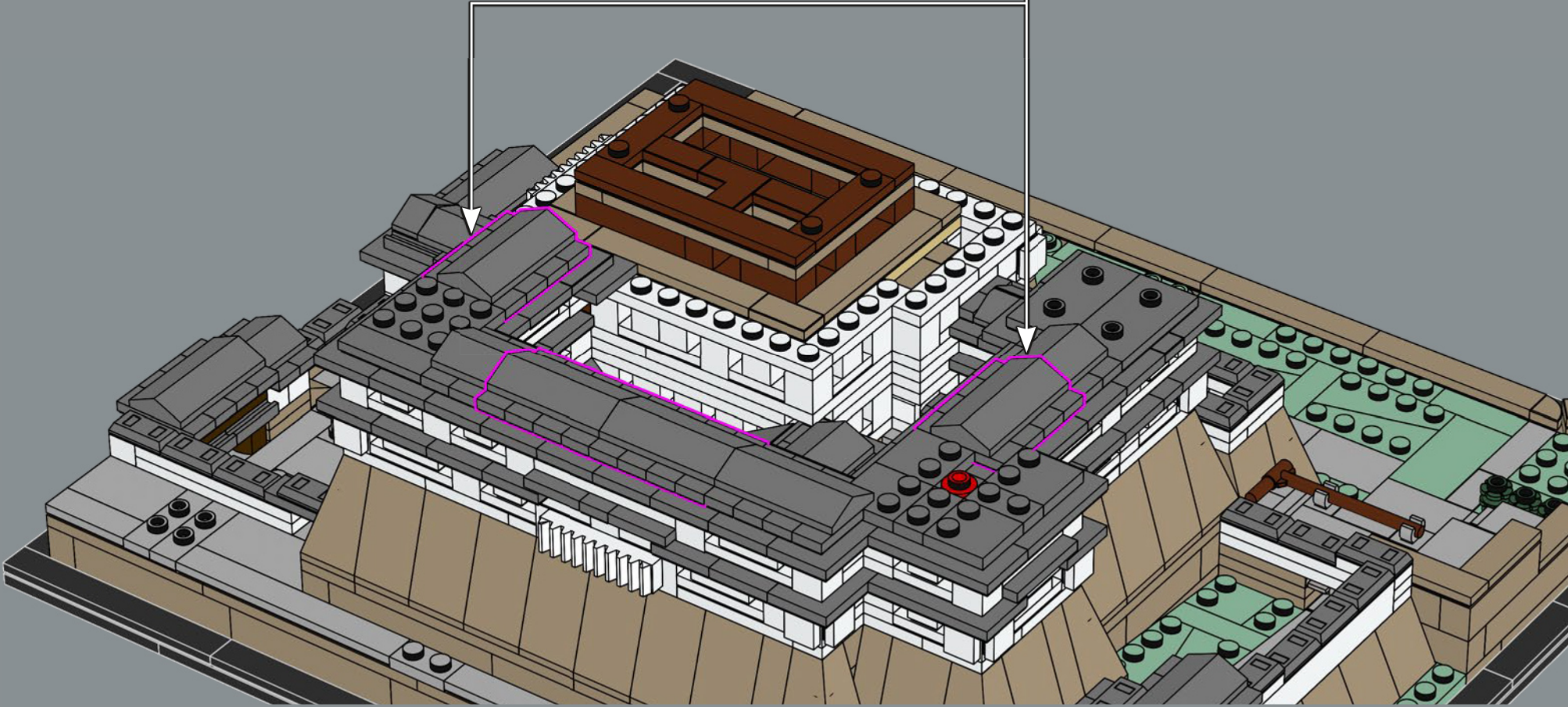
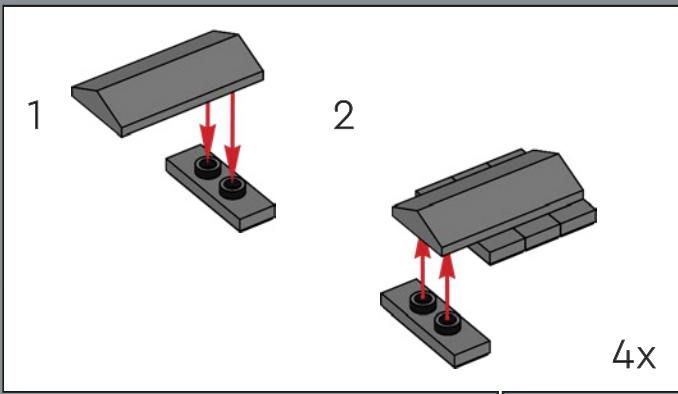

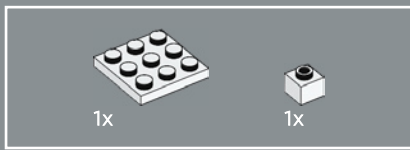

227

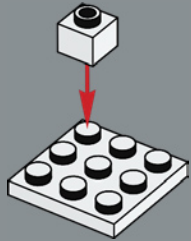

228

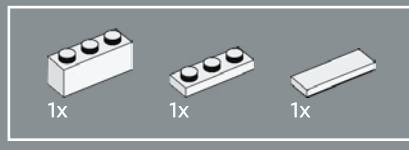
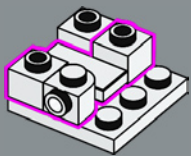

229

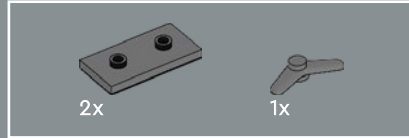
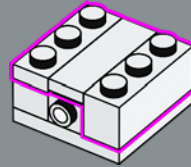

230

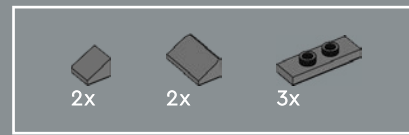
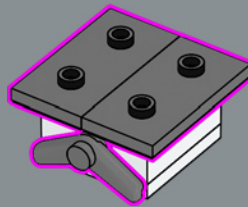

231

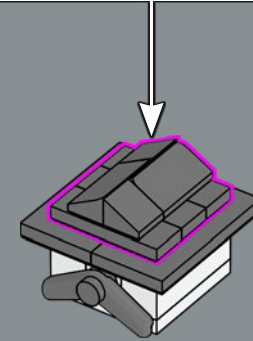
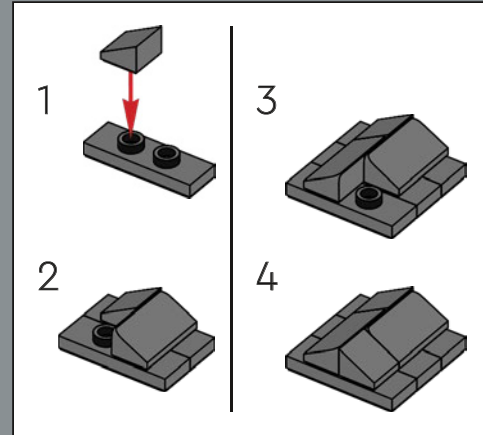

Tras años de exposición, la arcilla blanca del tejado empieza a ensuciarse, cambiando lentamente el aspecto y el color del tejado.

232

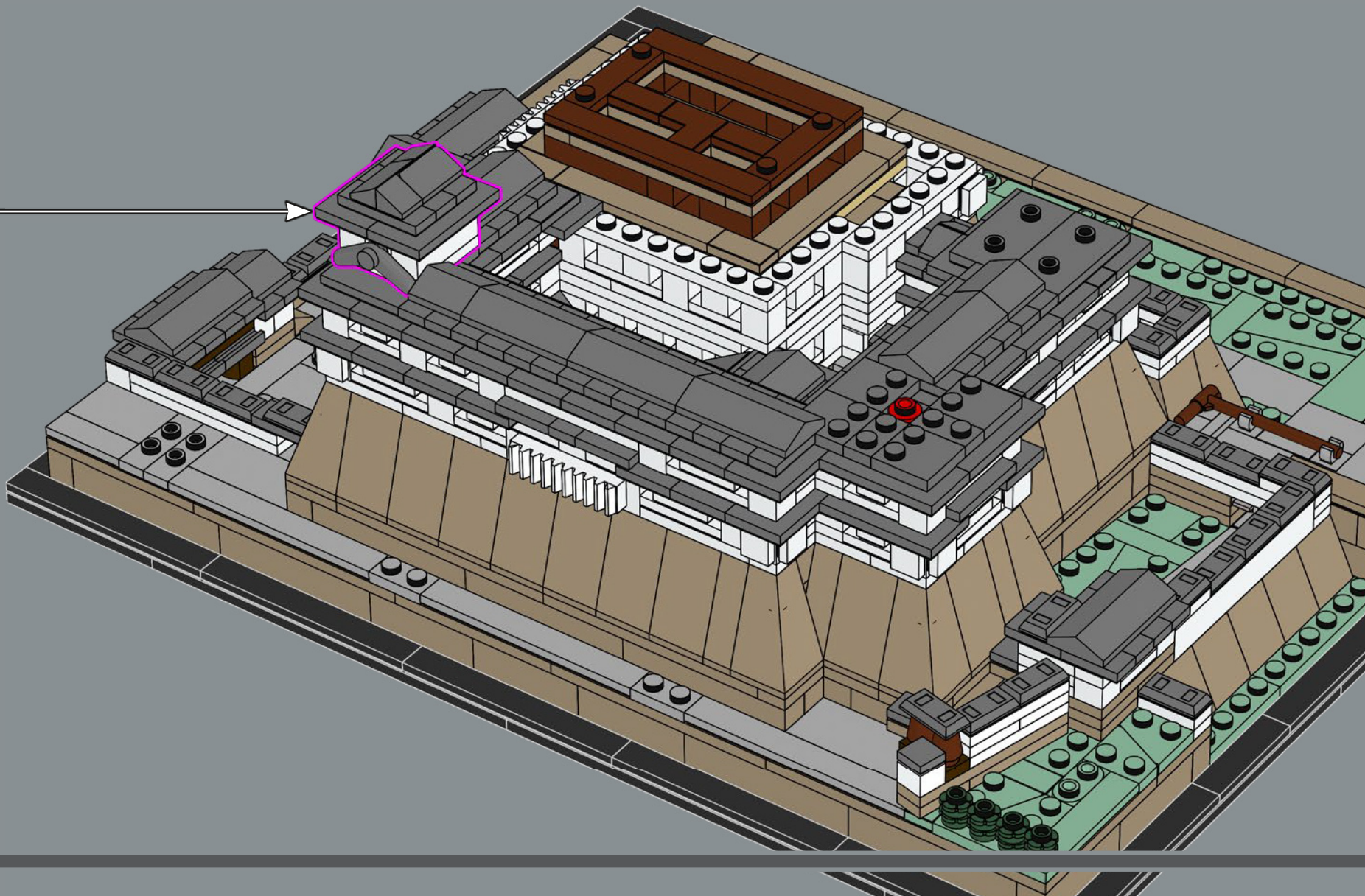

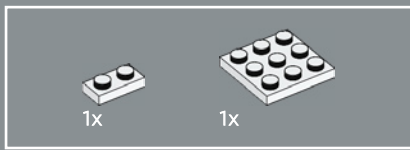

233

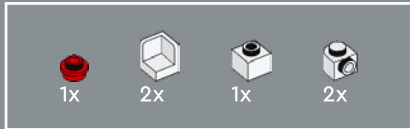
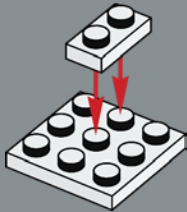

234

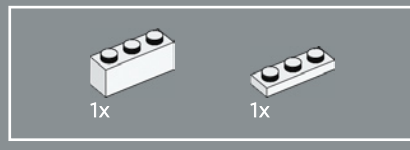
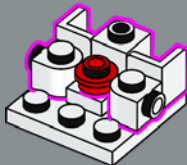

235

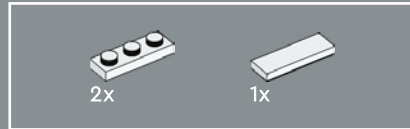
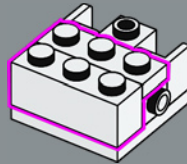

236

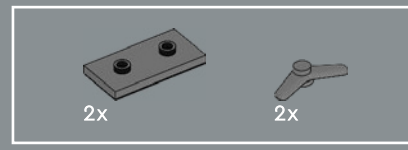
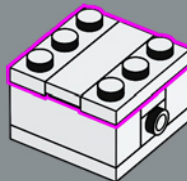

237

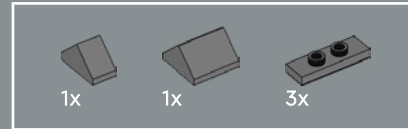
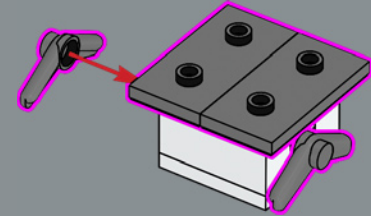

238

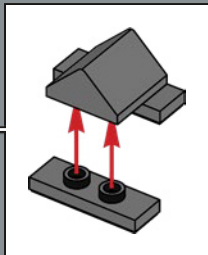
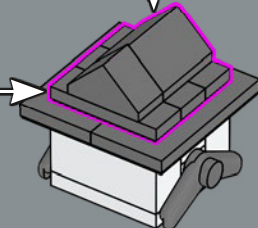
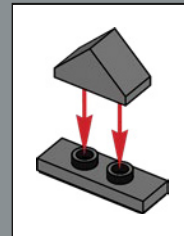

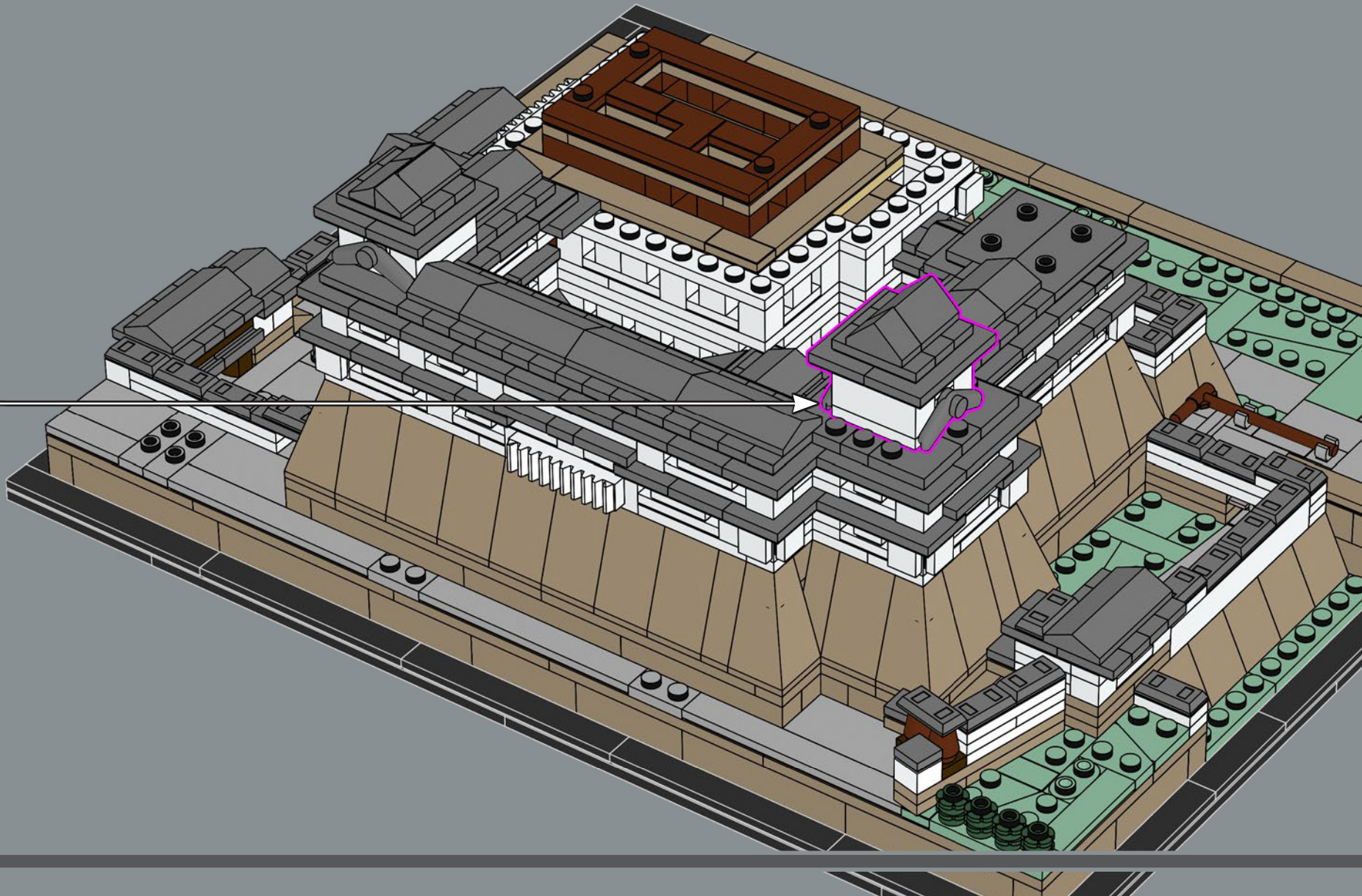



240

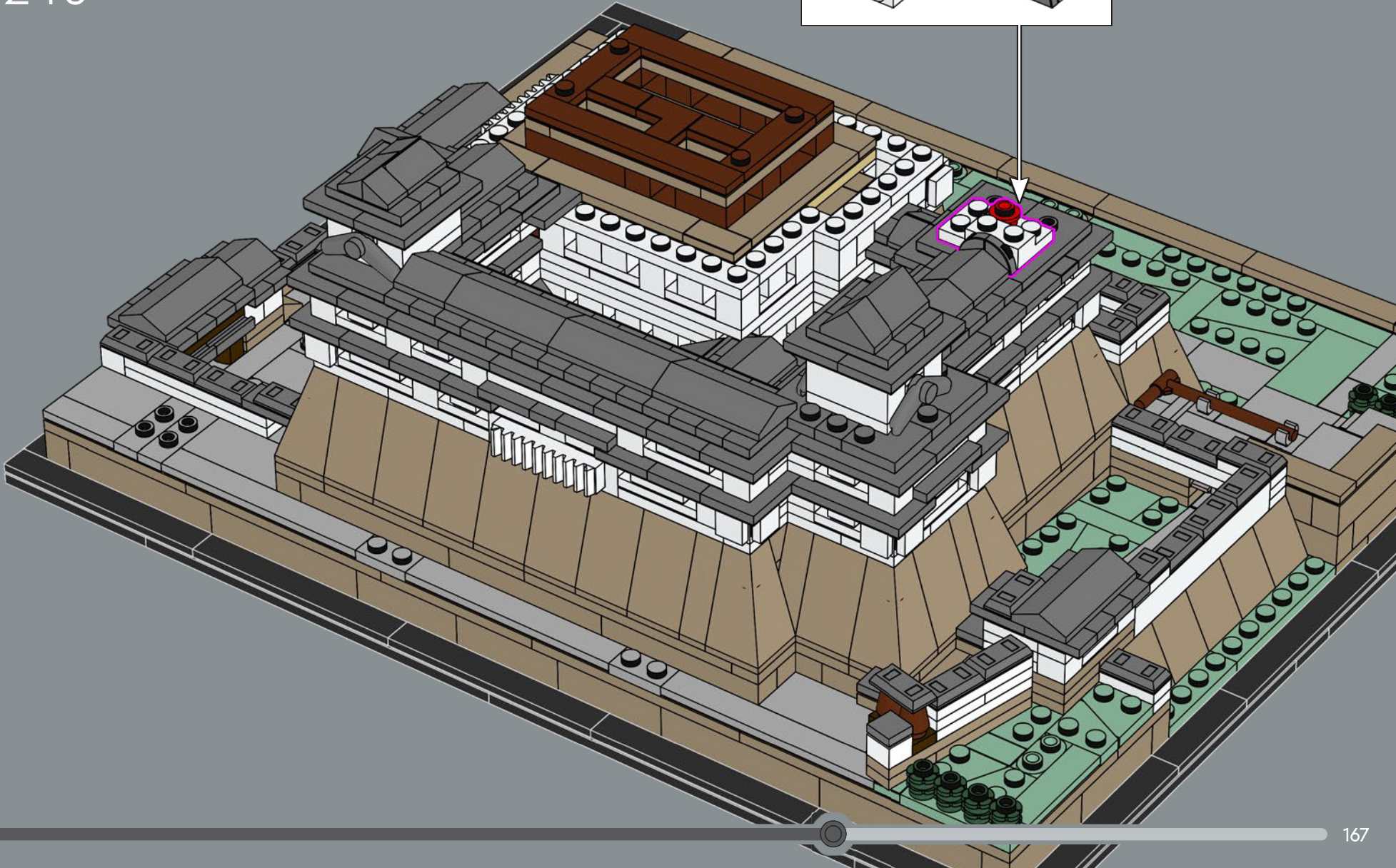
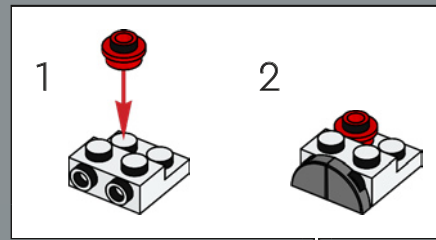

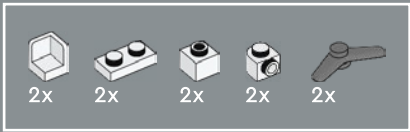

241

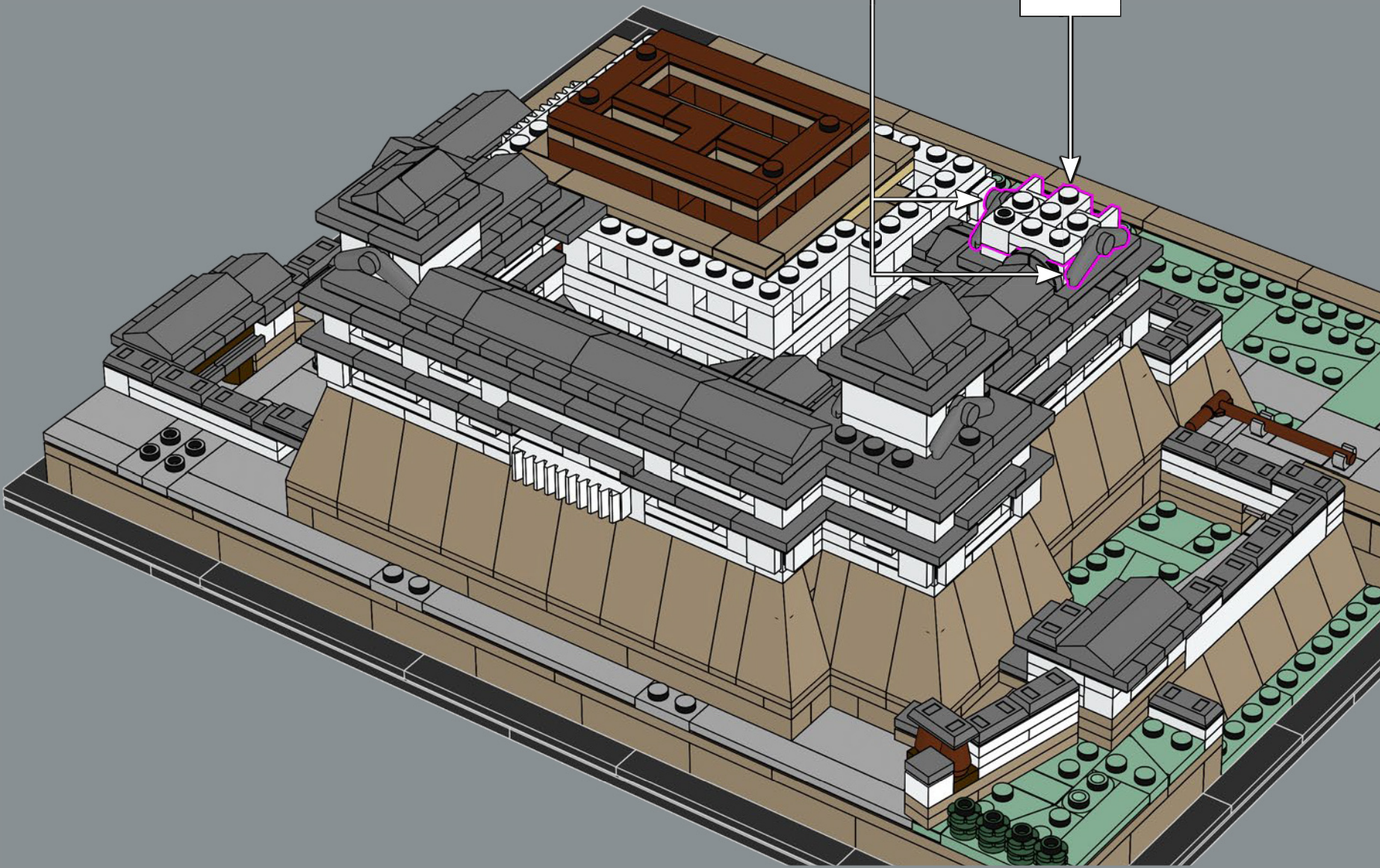
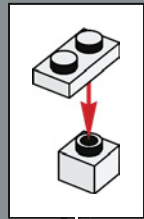
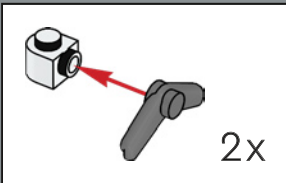

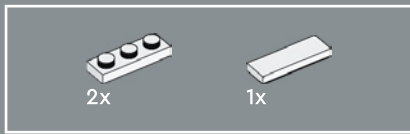

242

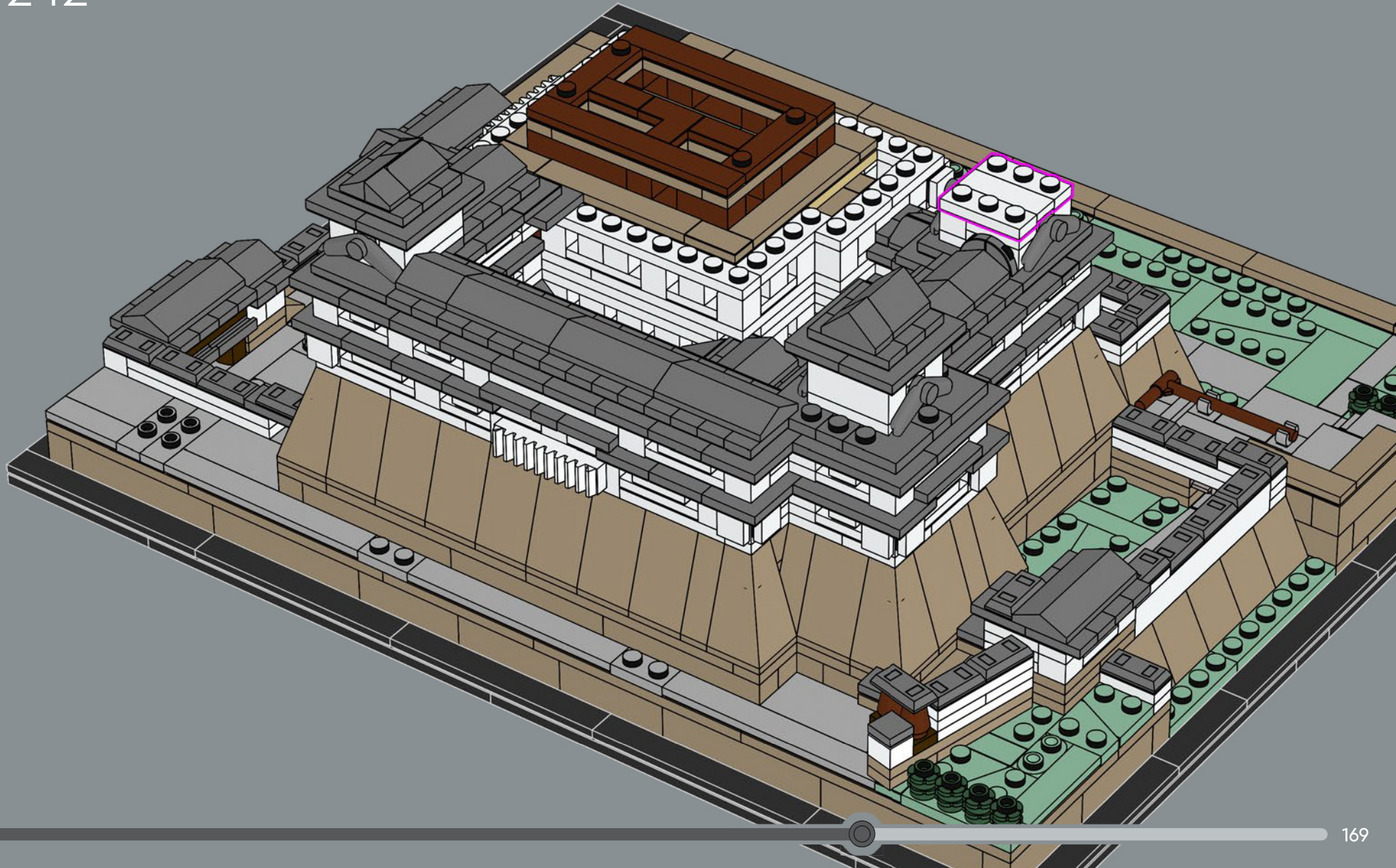

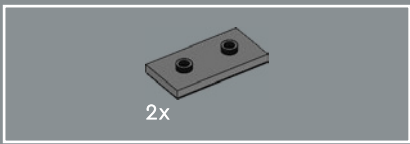

243

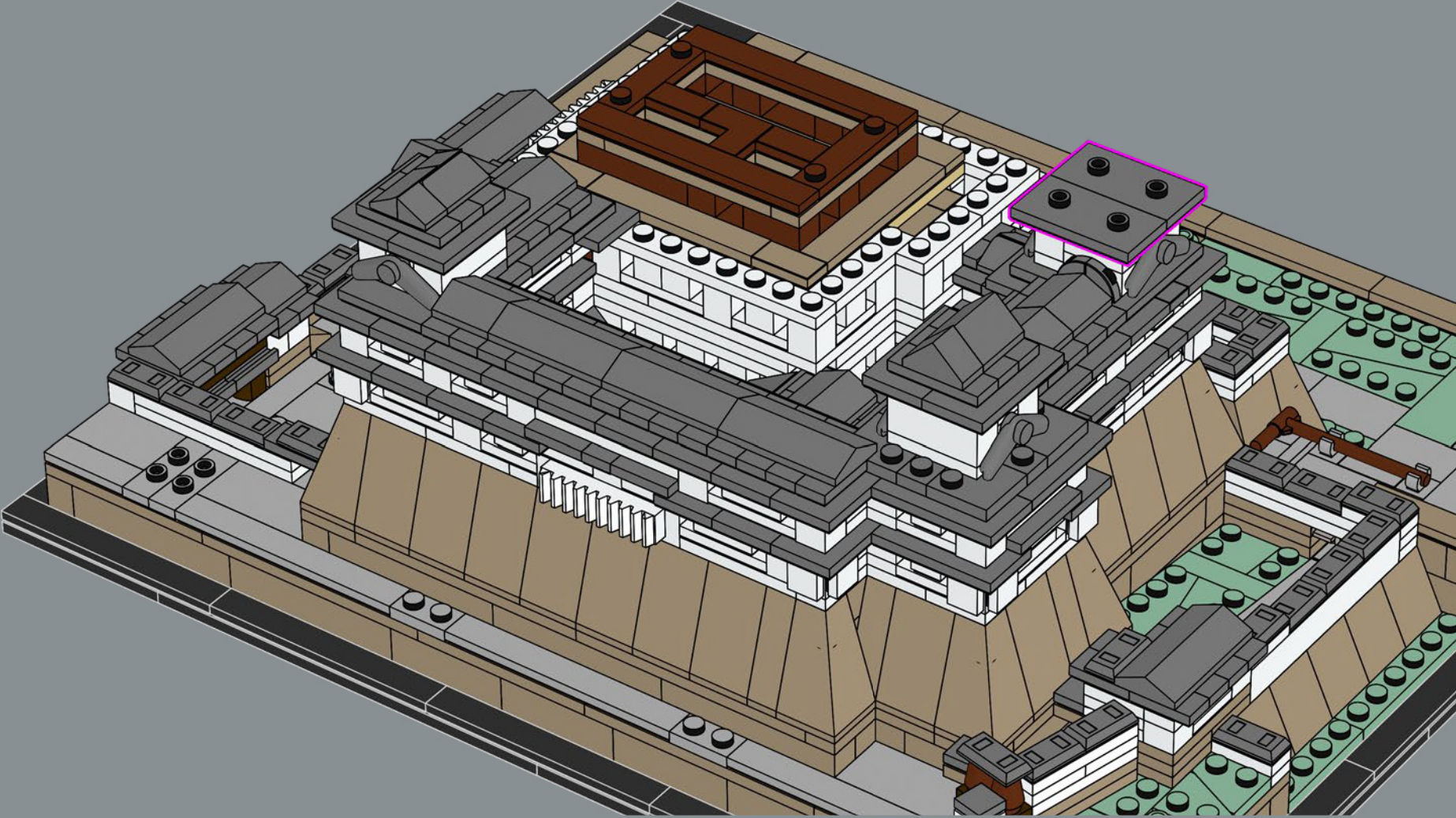

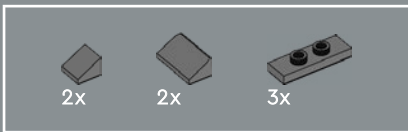

244

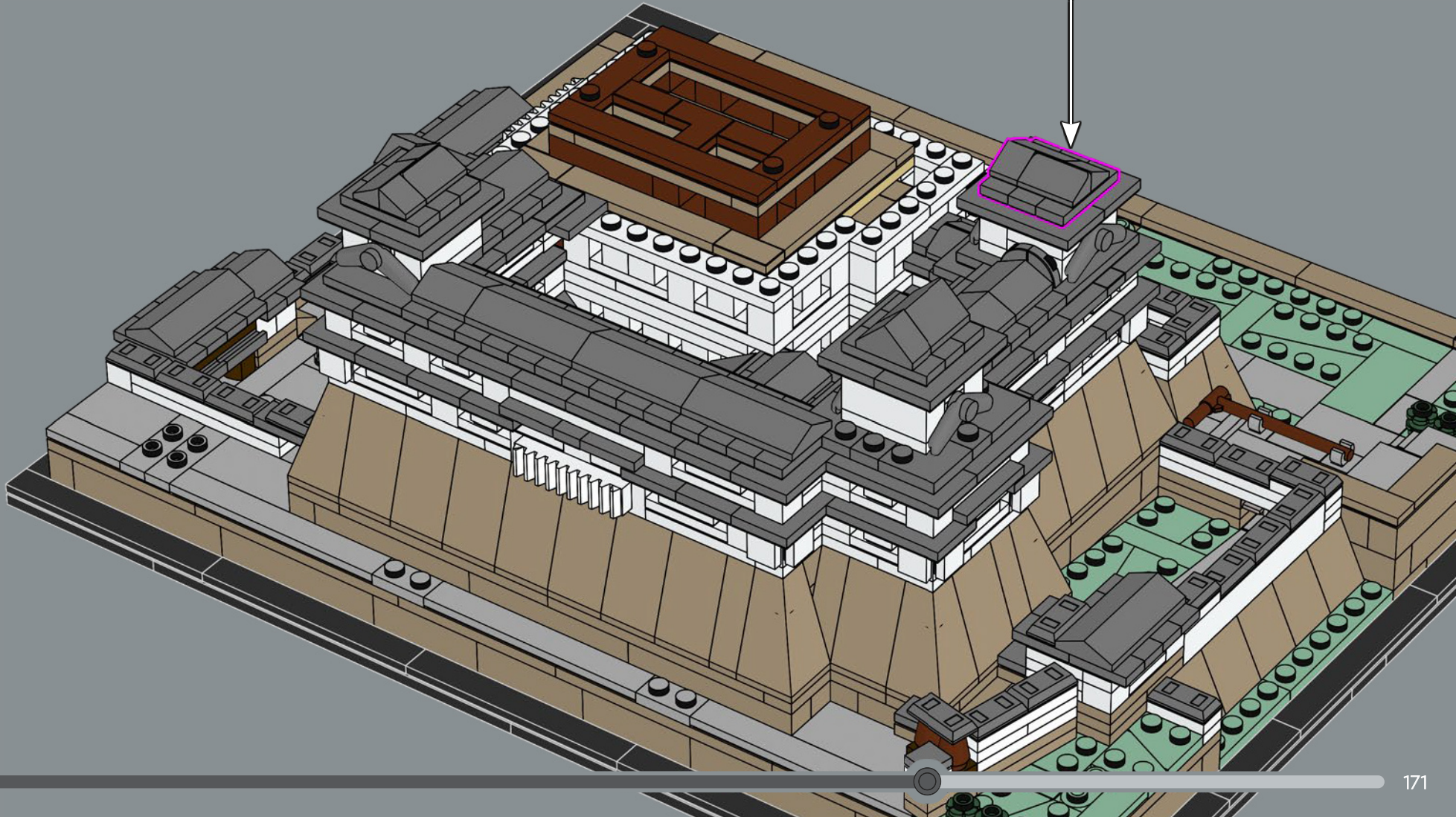
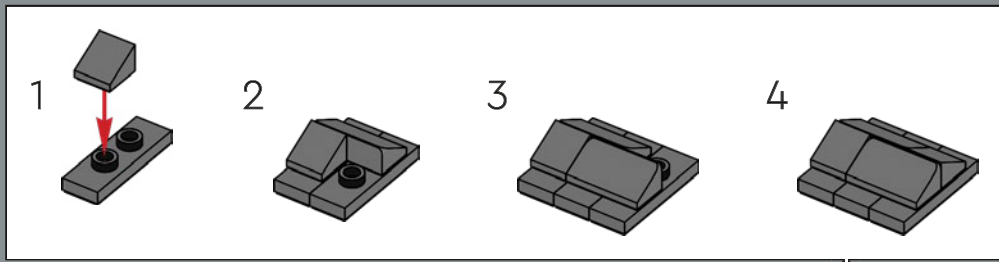

La nueva esquina arqueada 2x2 es el segundo elemento INÉDITO que se aprueba para un set LEGO® Architecture. El primero fue un elemento similar de tamaño 3x3 que formaba parte de la Casa Robie (21010), un modelo de 2011.

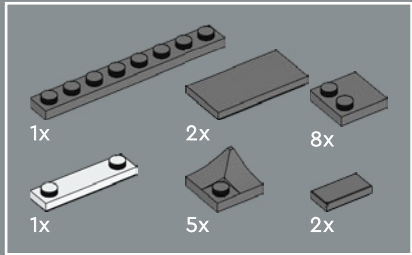

245

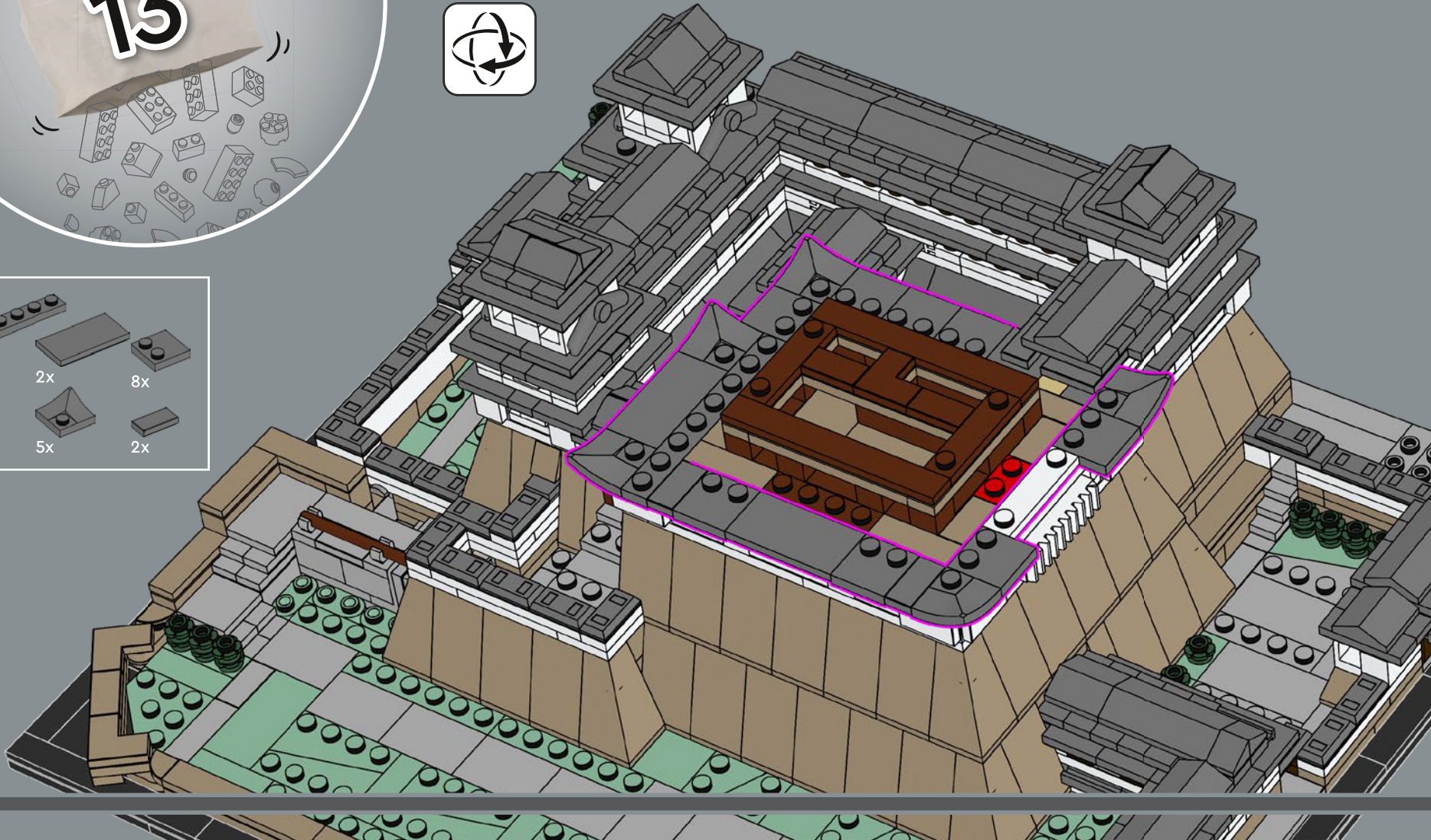

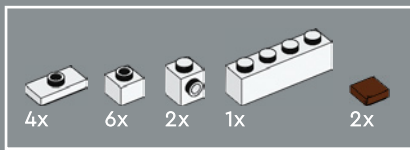

246

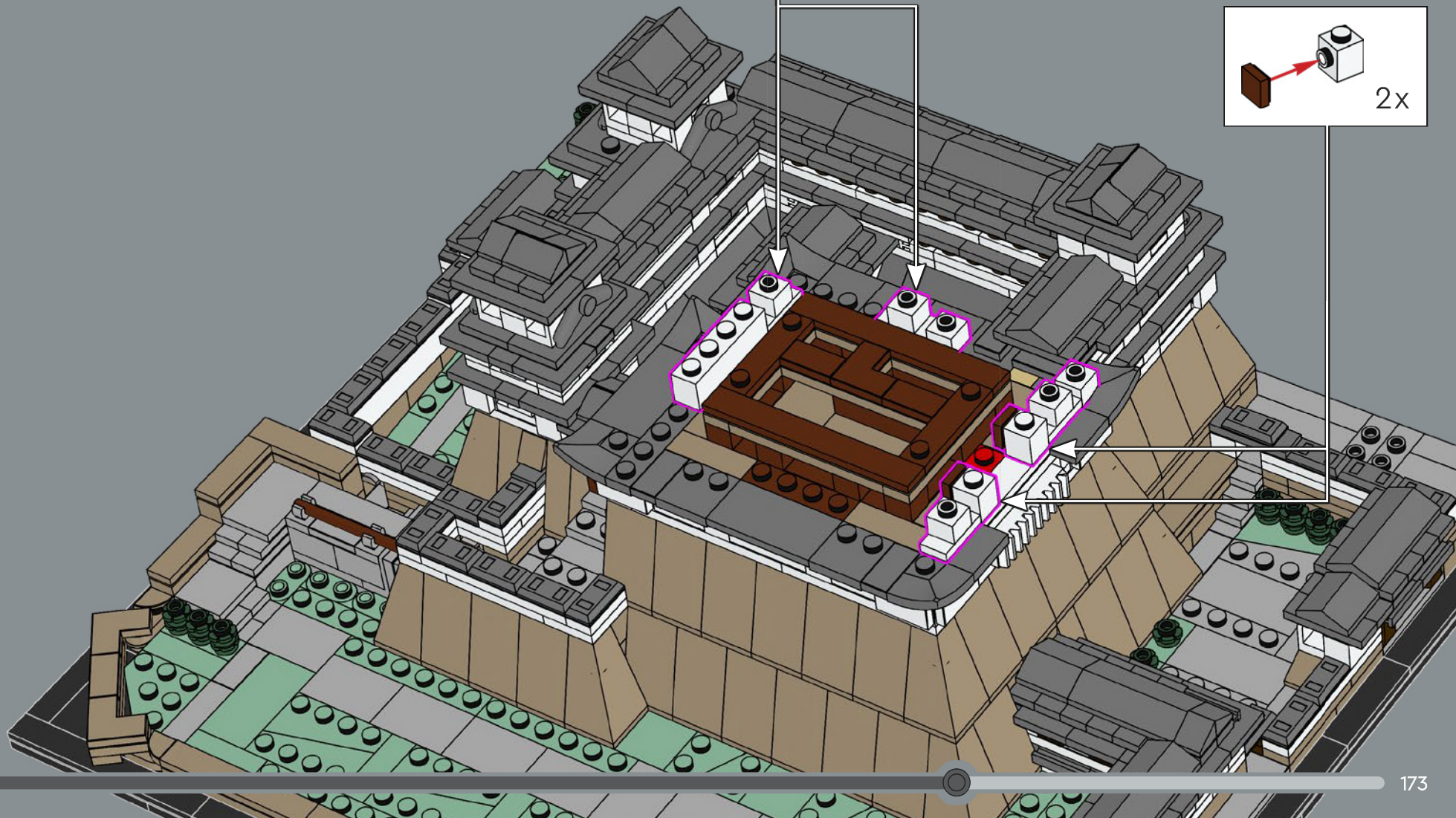
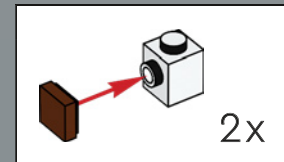
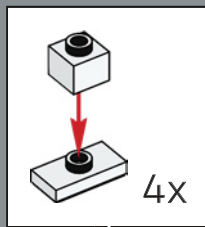

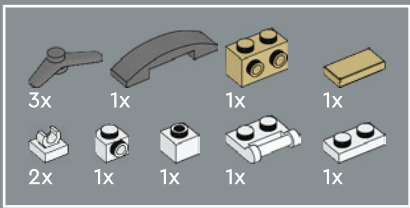

247

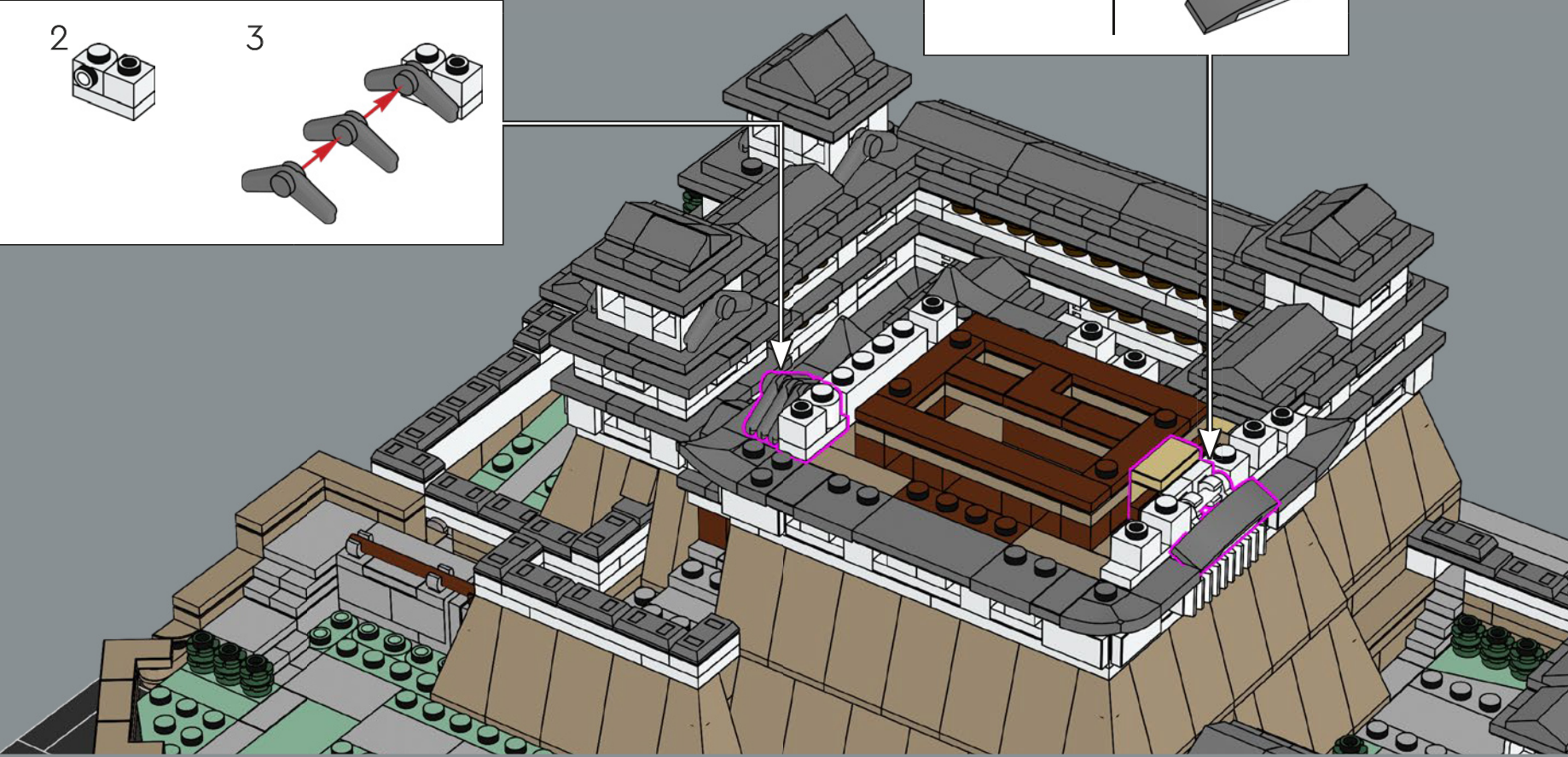
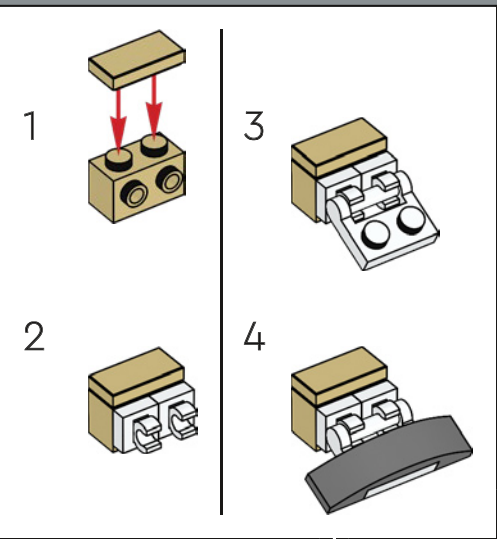
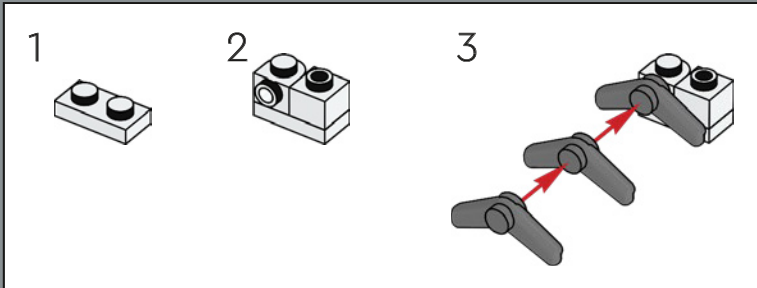

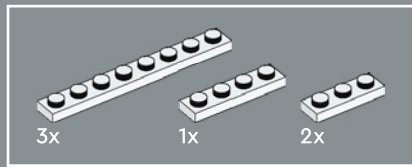

248

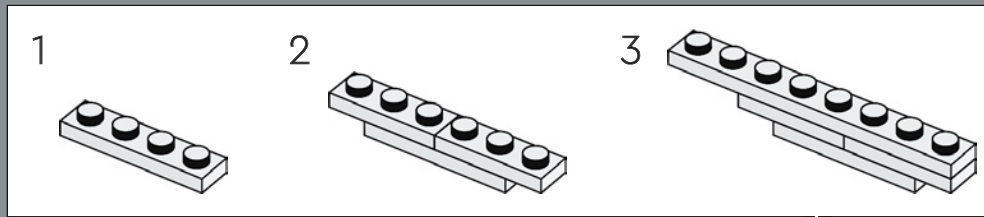

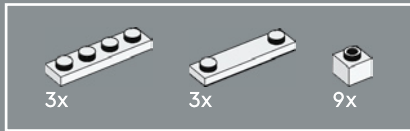
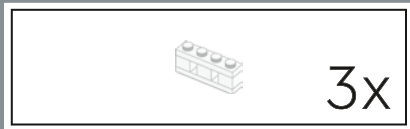

249

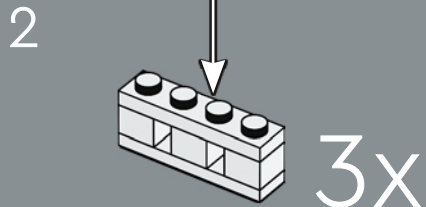
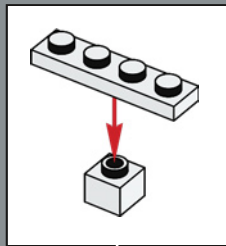
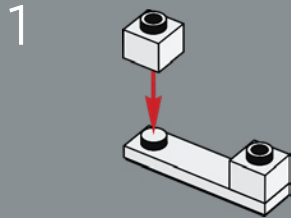

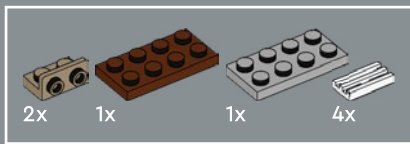

250

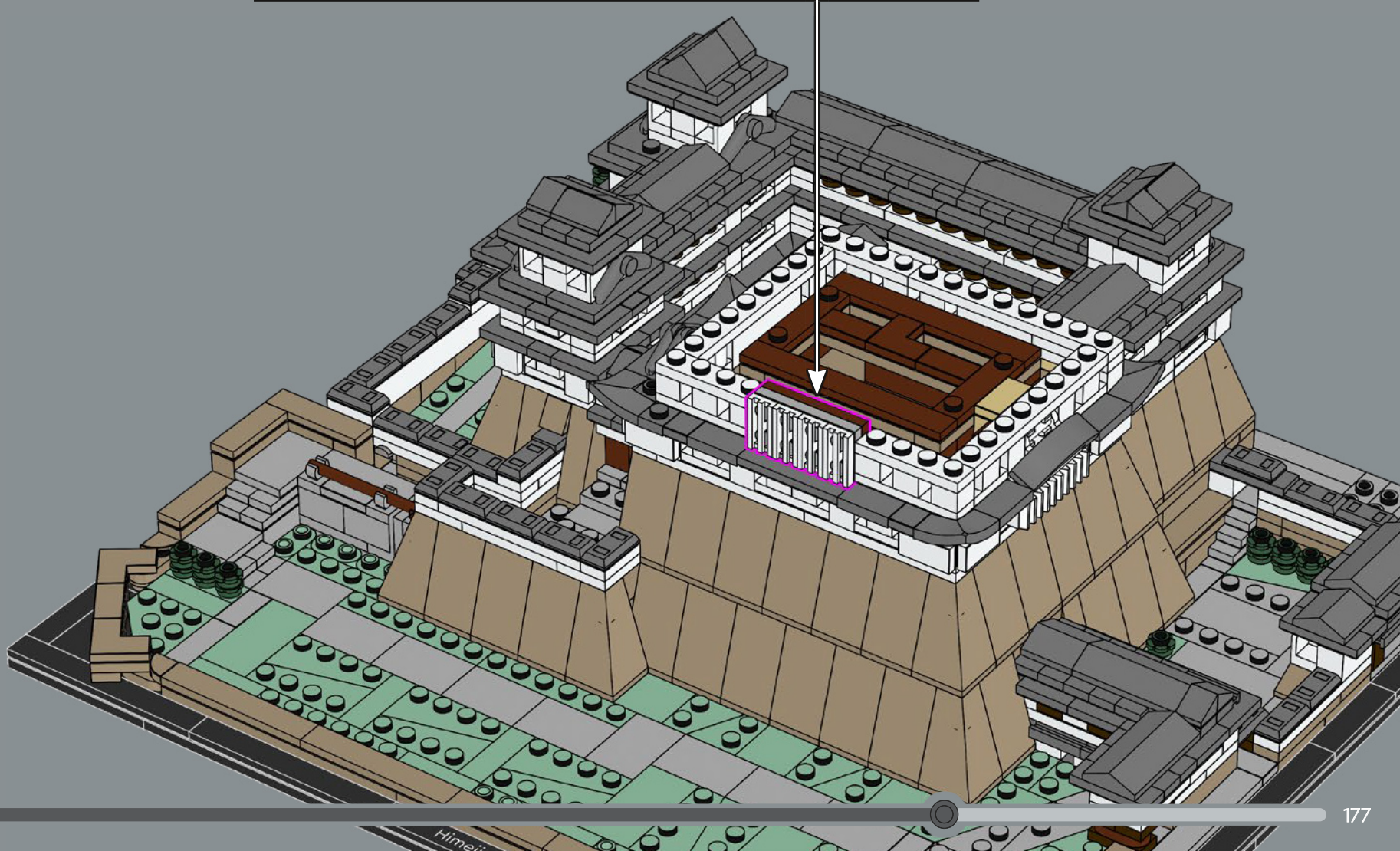
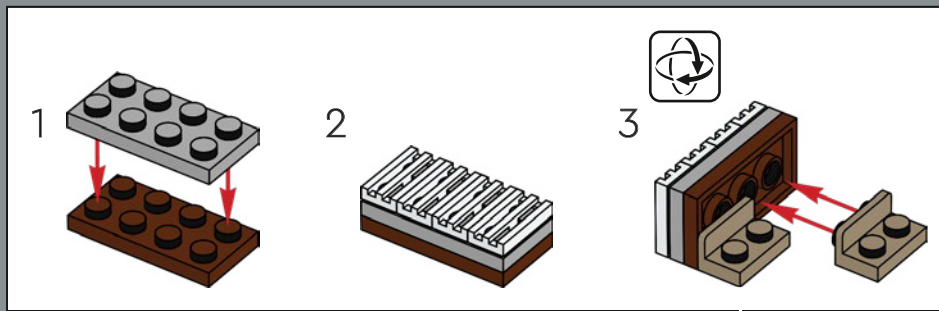

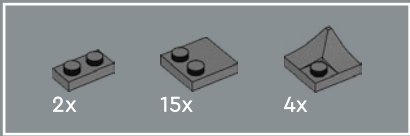

251



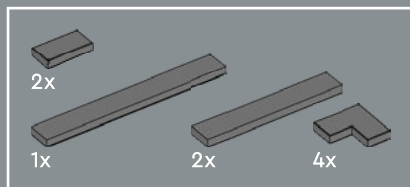

252

La parte superior de la estructura se puede retirar para ver algunos de los espacios interiores, incluida la zona consistorial, en su mayor parte vacía, tal como lucía durante la restauración de 2009-2015.

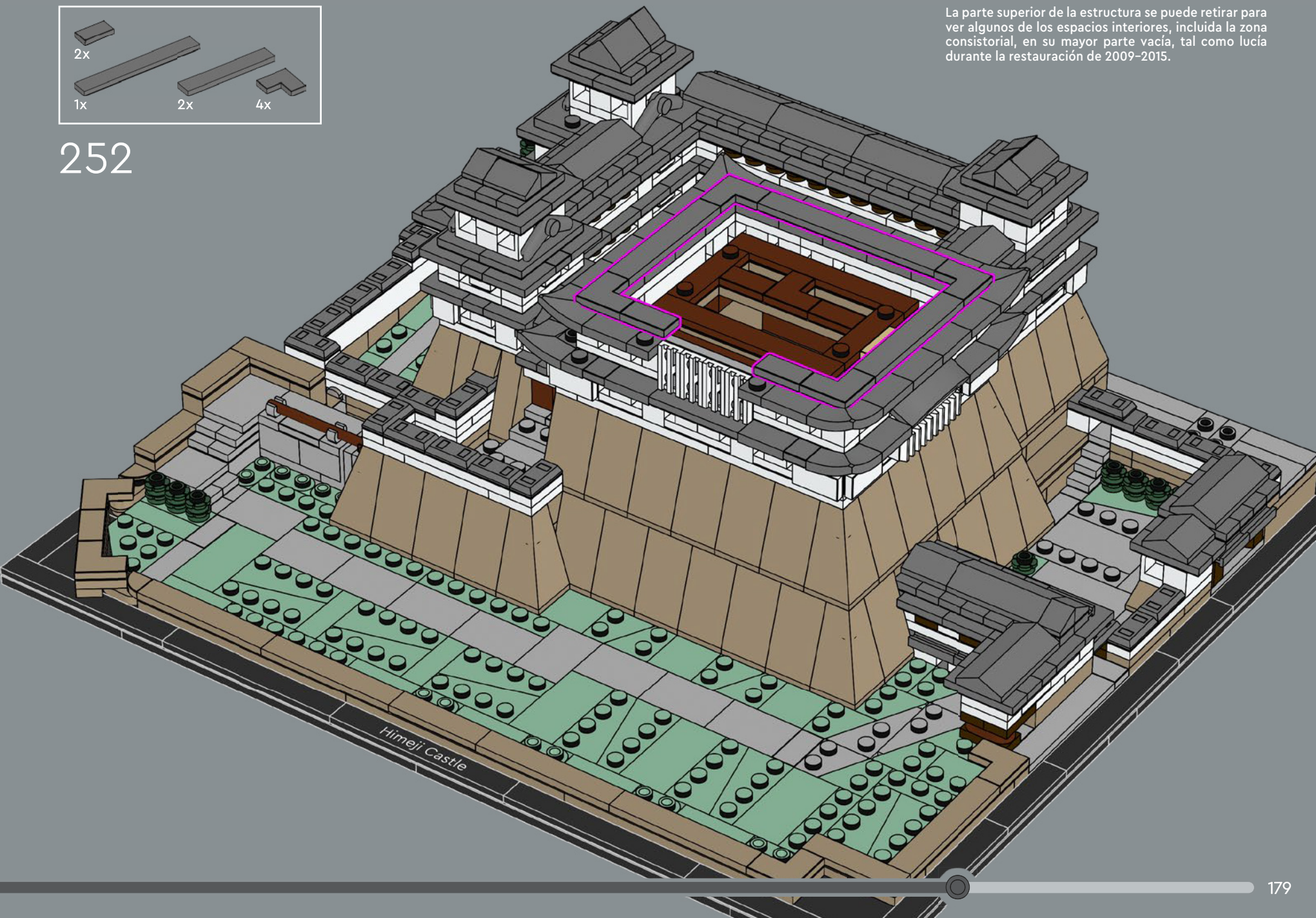

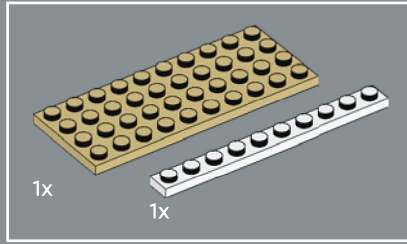
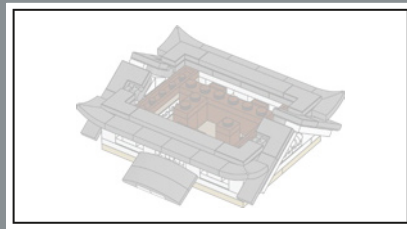

253

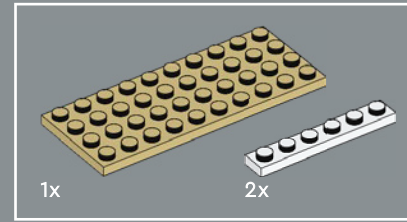
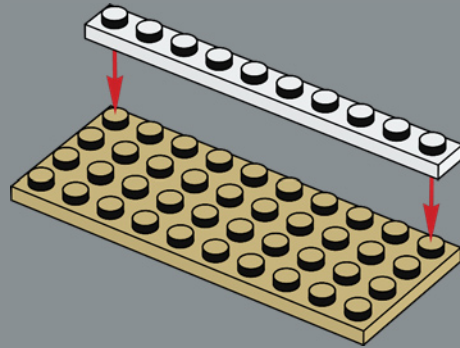

254

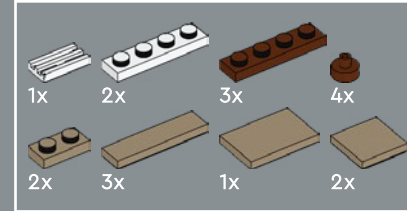
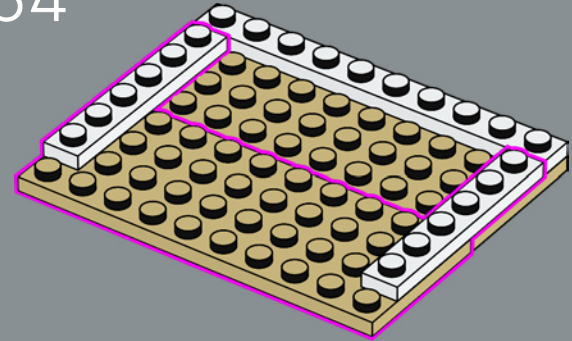

255

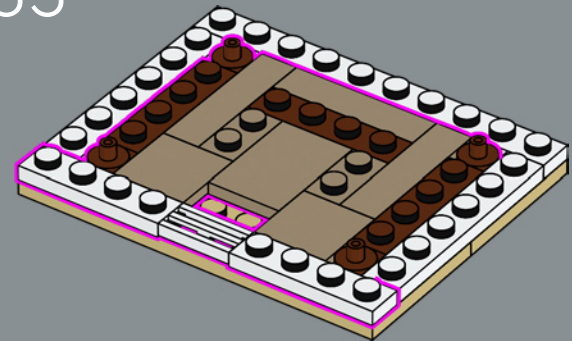

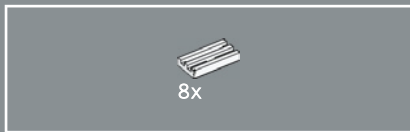

256

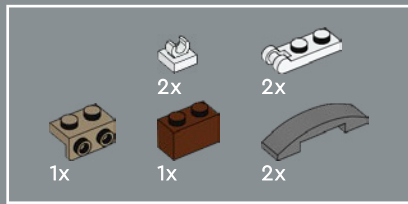
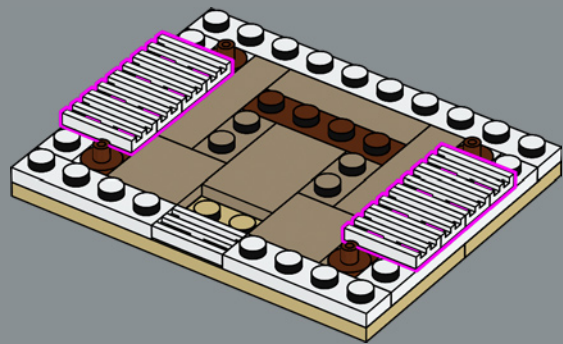

257

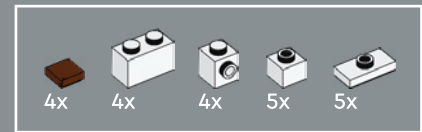
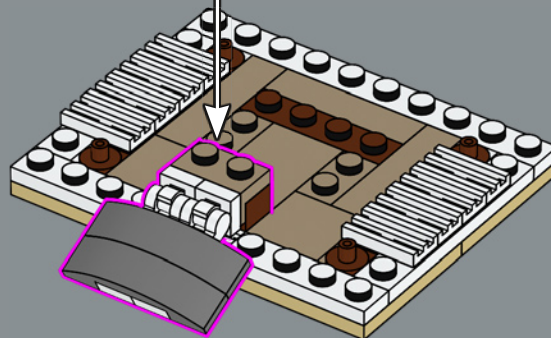
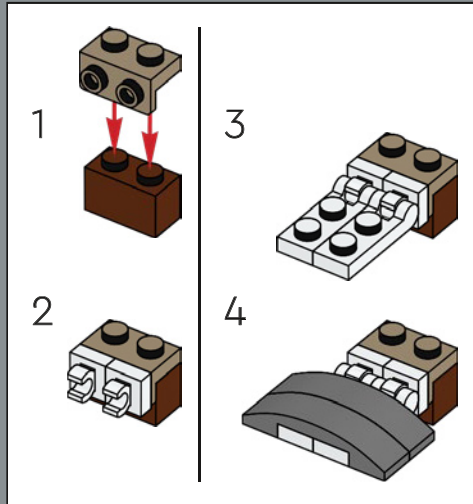

258

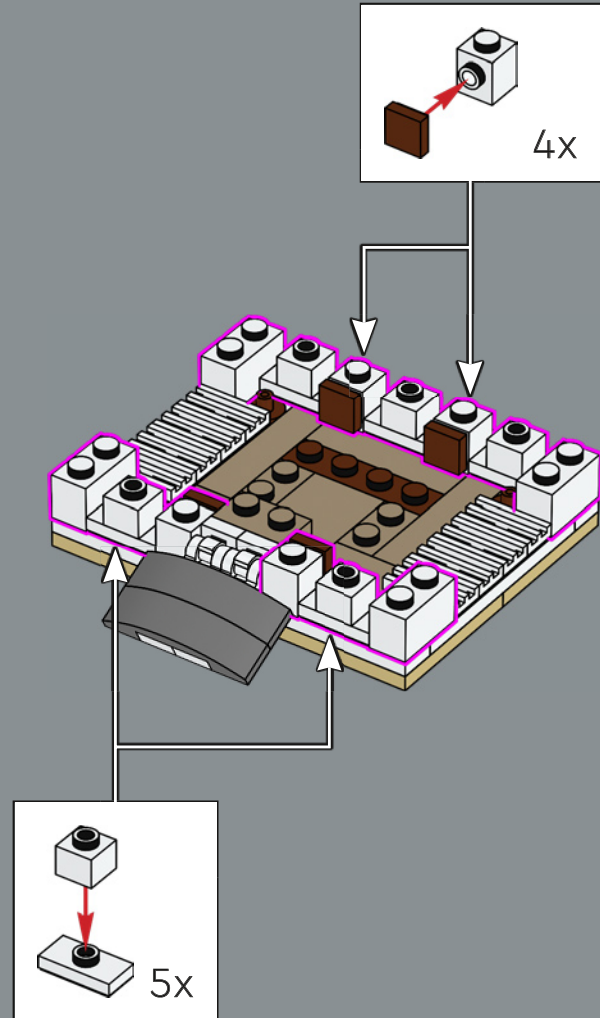

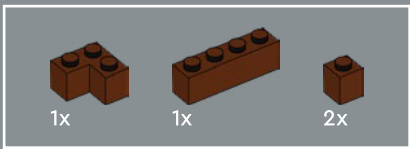

259

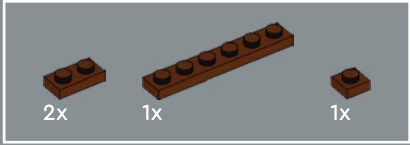
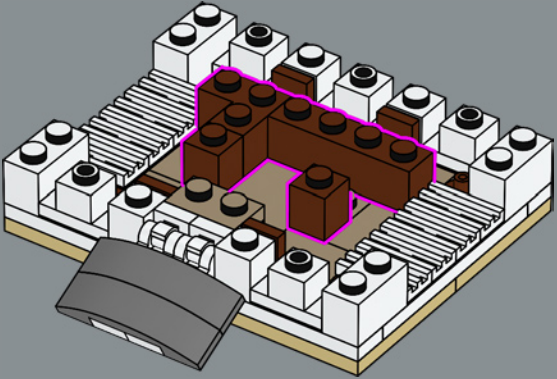

260

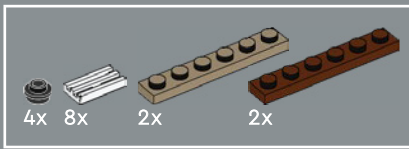
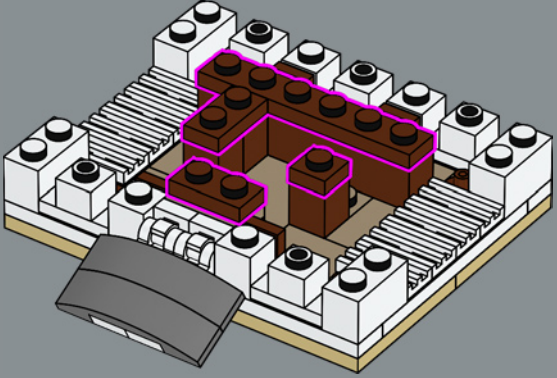

261

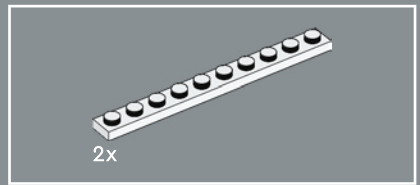
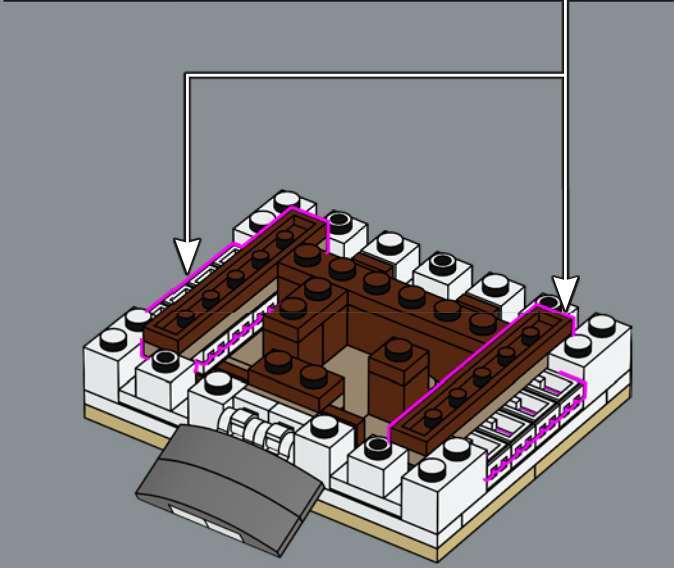
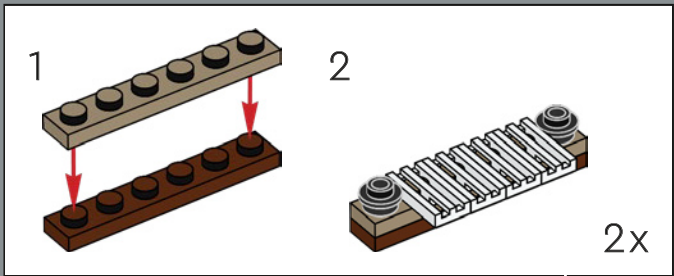

262

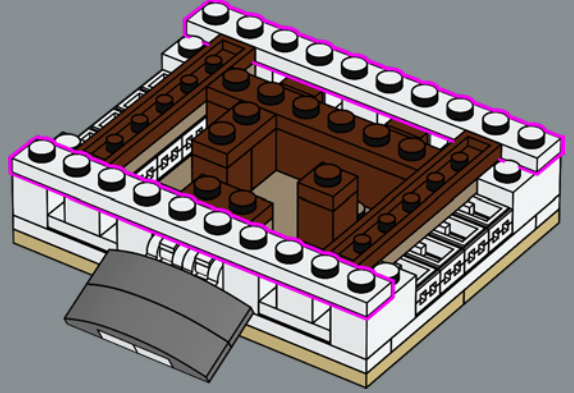

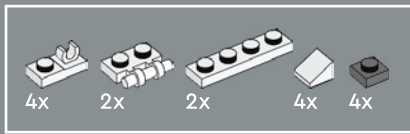

263

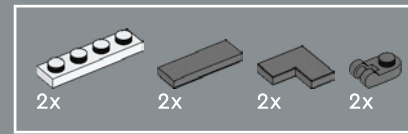
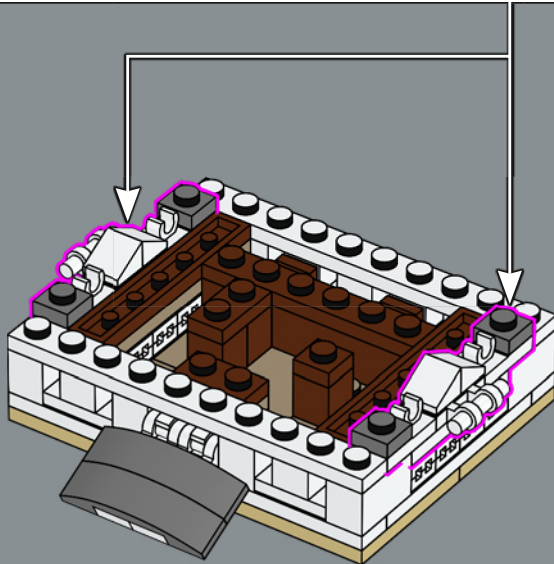
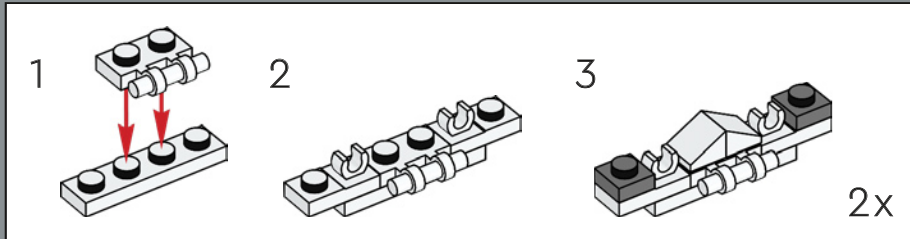

264

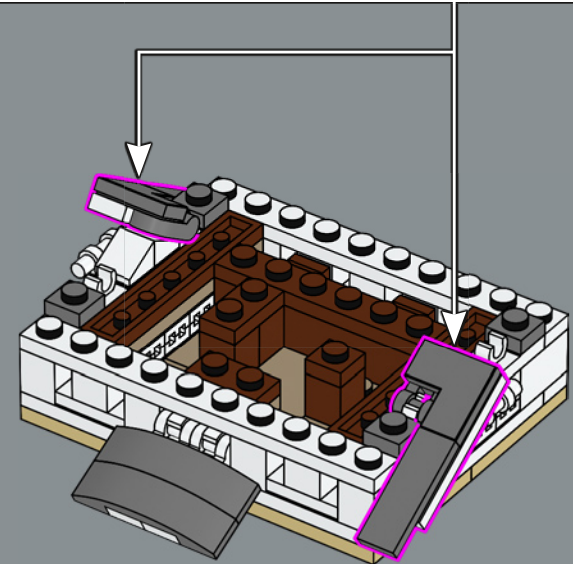
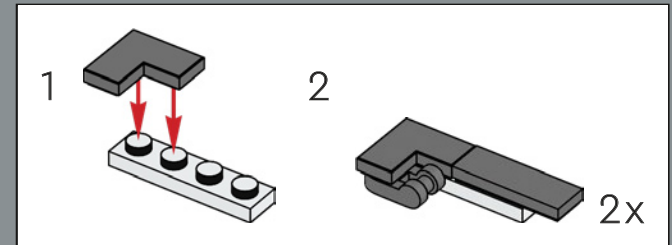

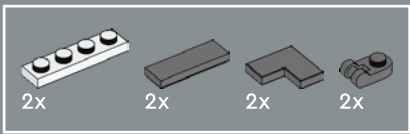

Cada planta de la torre principal del castillo tiene una distribución diferente, inspirada en los planos del castillo original.

265

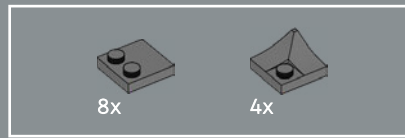
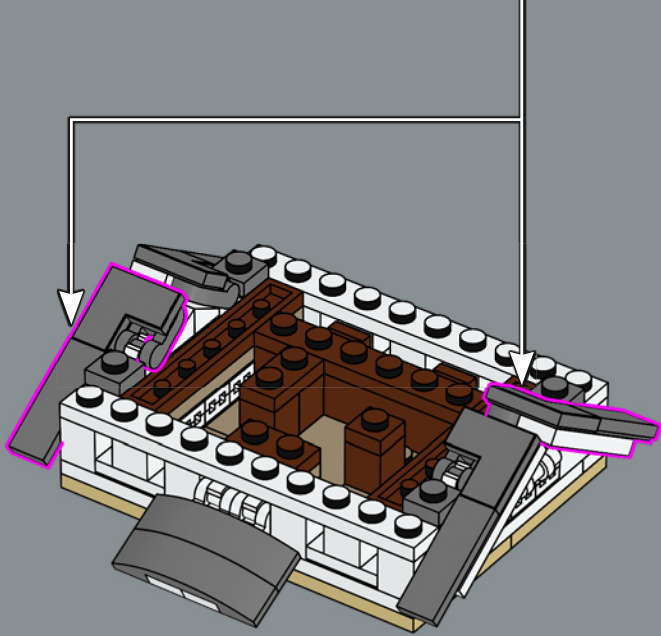
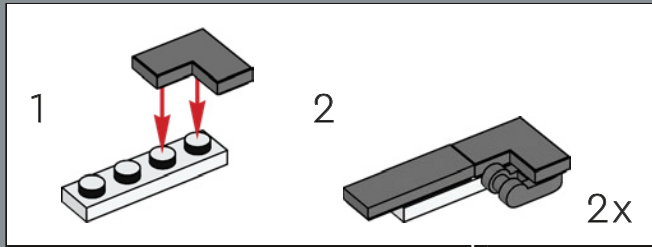

266

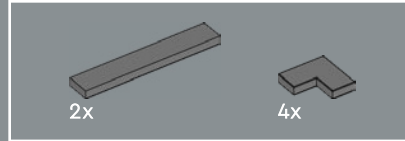
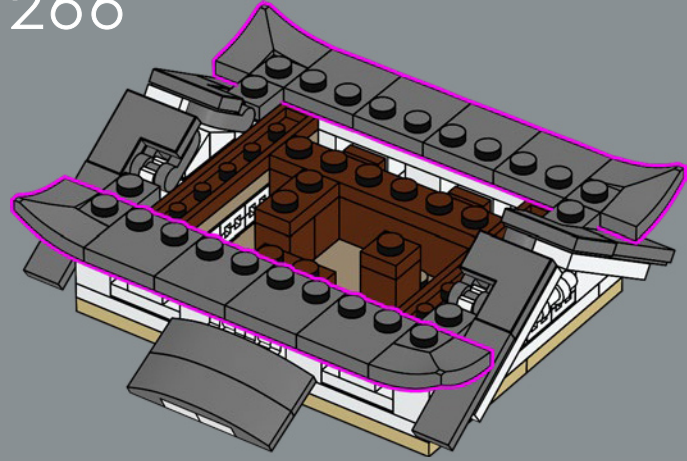

267

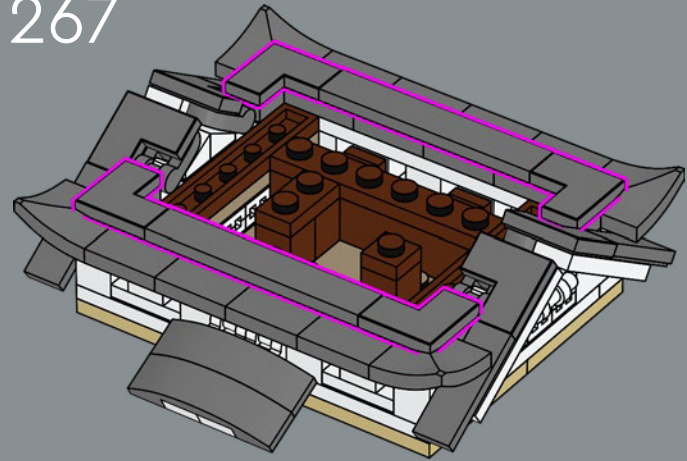

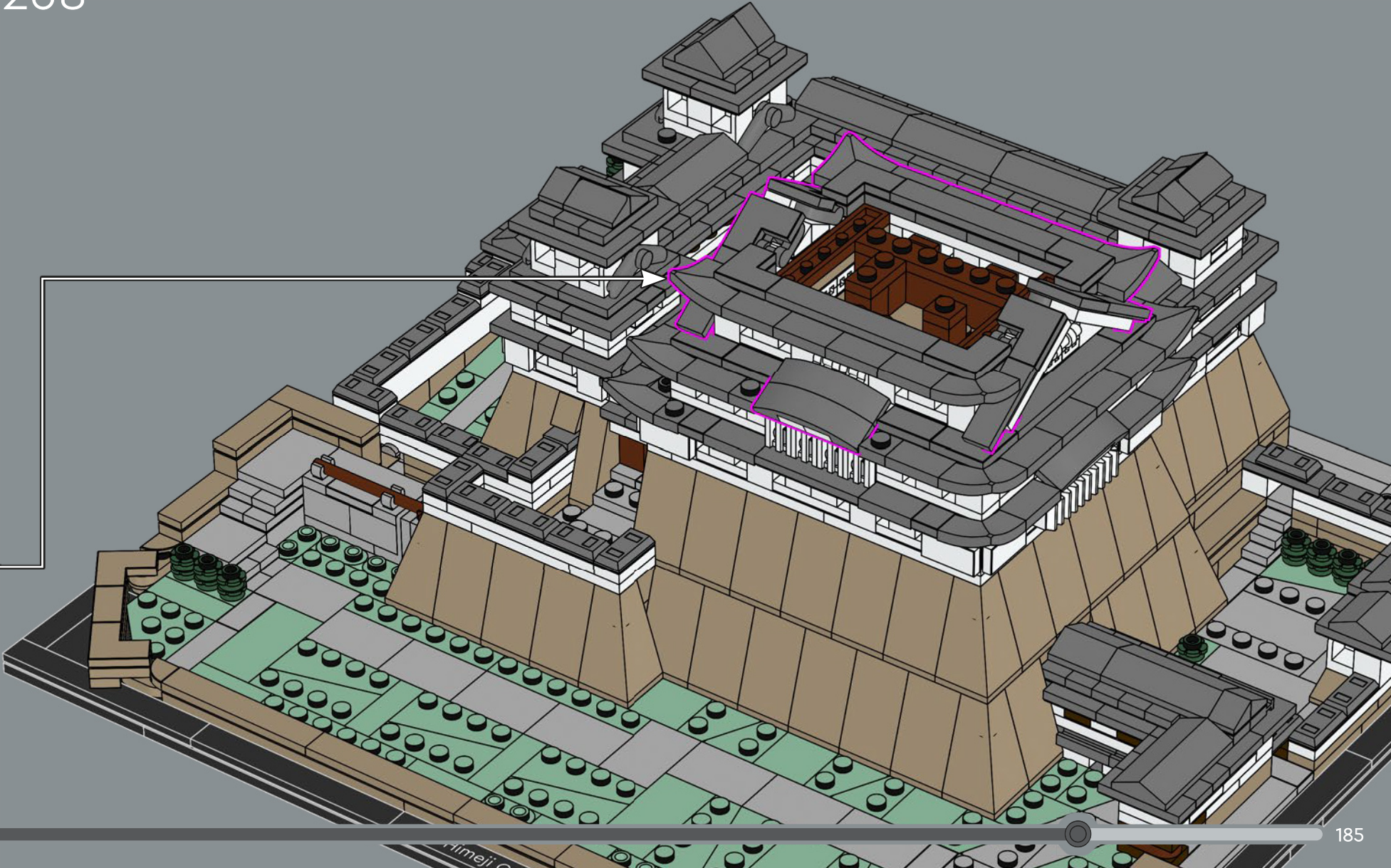

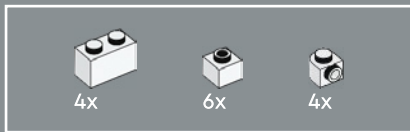

272

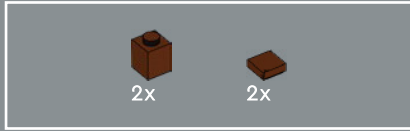
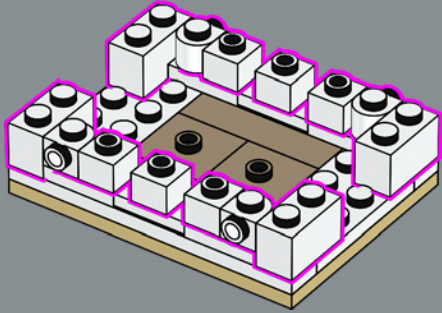

273

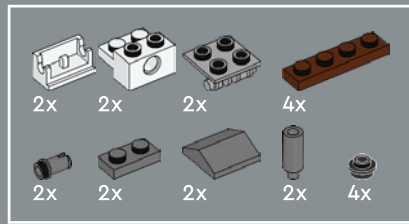
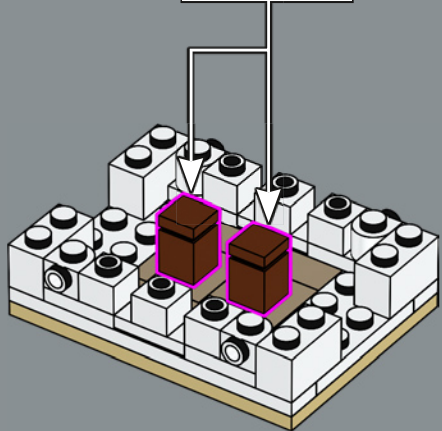
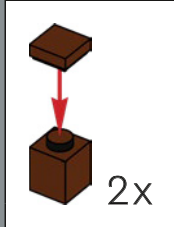

274

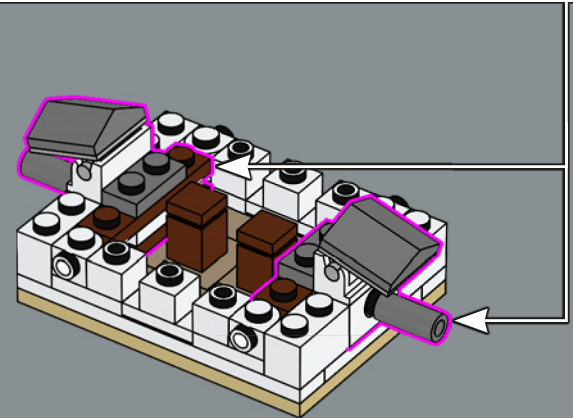
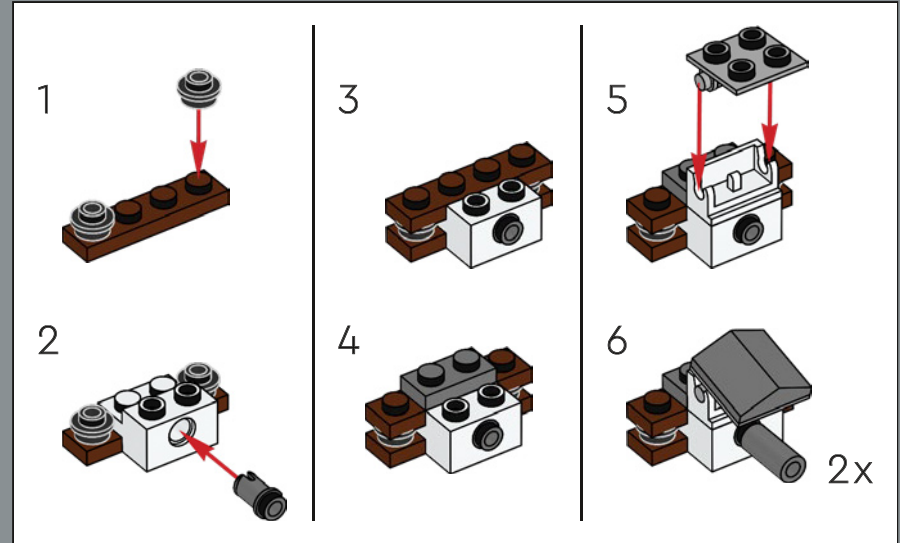

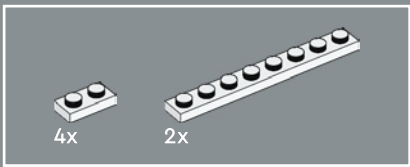

275

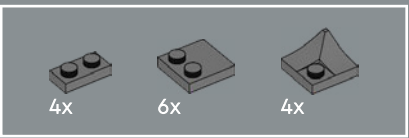
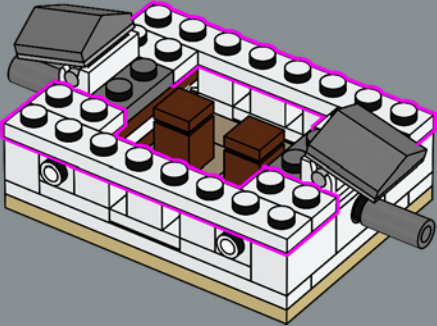

277

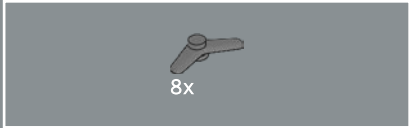
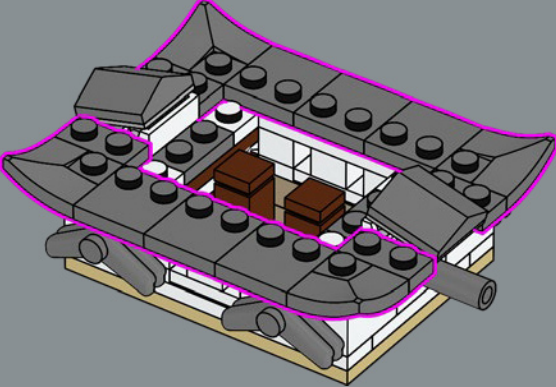

276

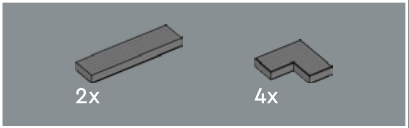
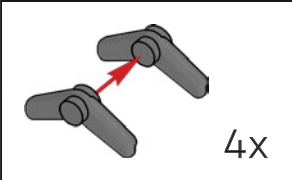
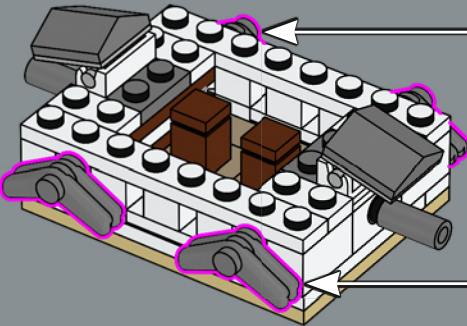

278

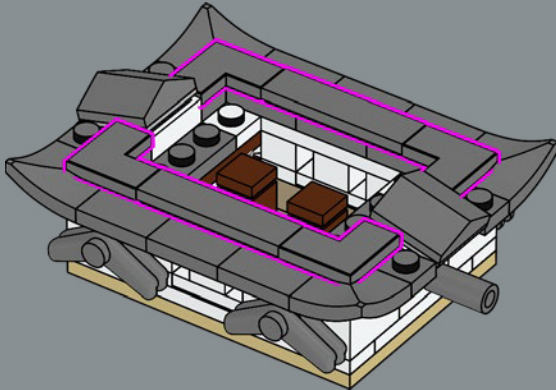

Los tejadillos que sobresalen por encima de las estructuras de las ventanas se construyen en parte con bumeranes LEGO®.

279

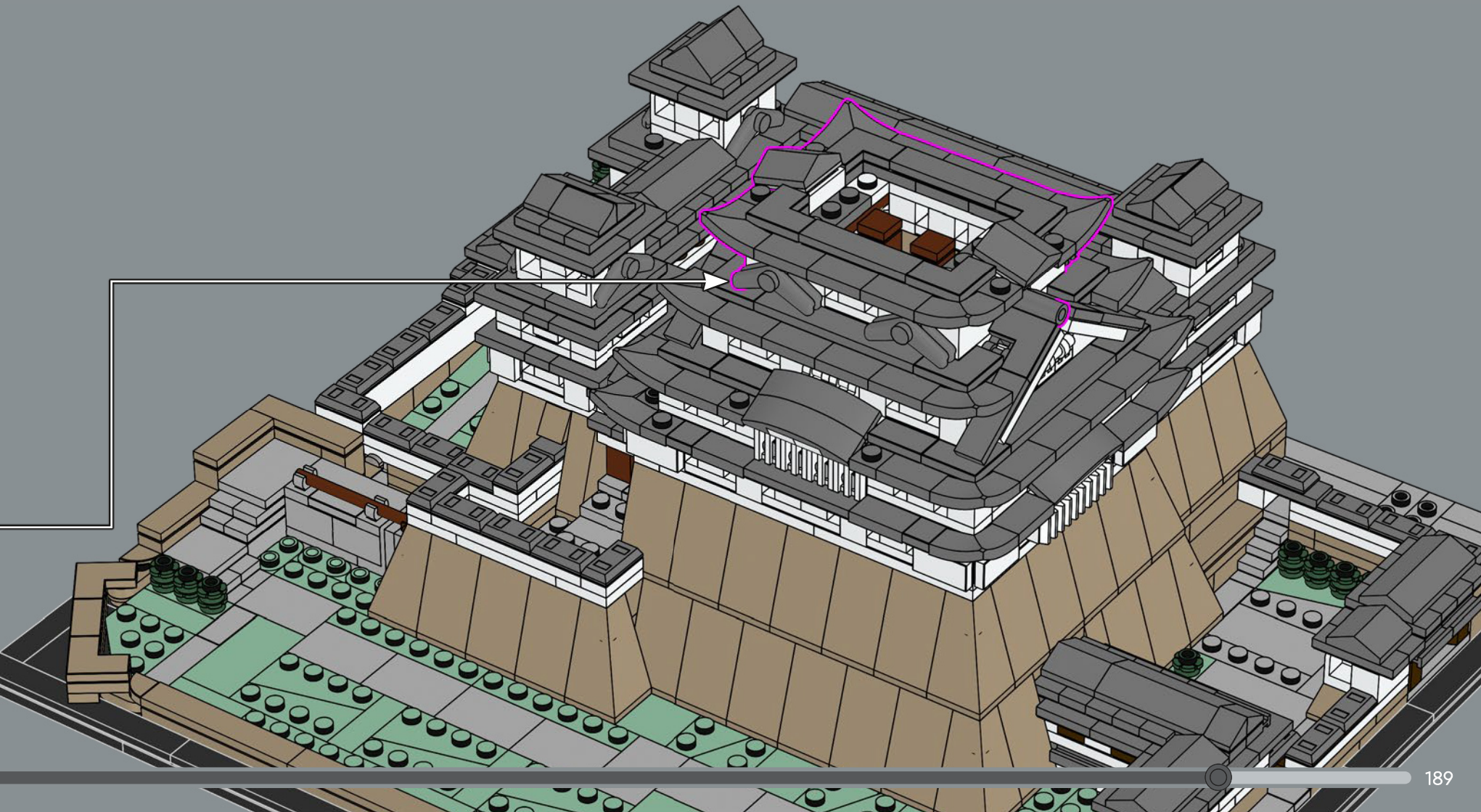

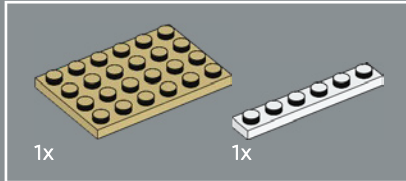
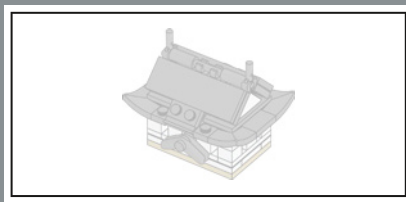

280

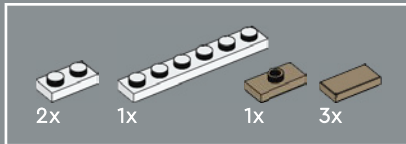
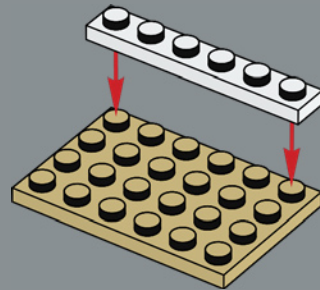

281

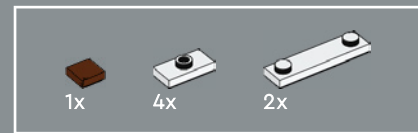
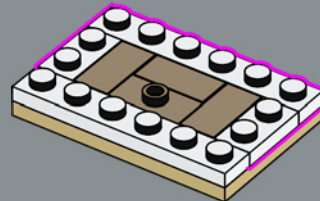

282

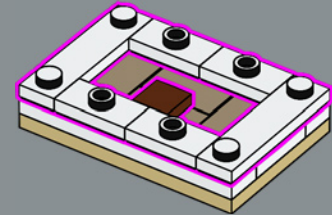

283

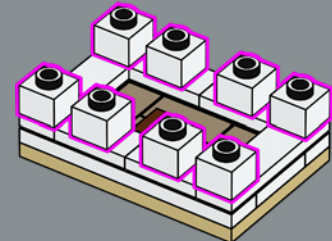

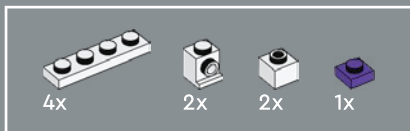

La baldosa púrpura 1x1 de la cámara ubicada en la planta superior de la torre principal hace referencia al pequeño santuario sagrado de madera cubierto con un paño púrpura que hay en el interior de esta cámara en el castillo.

284

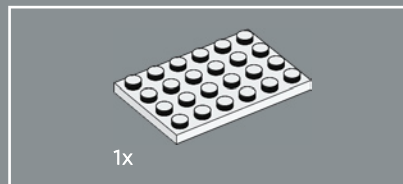
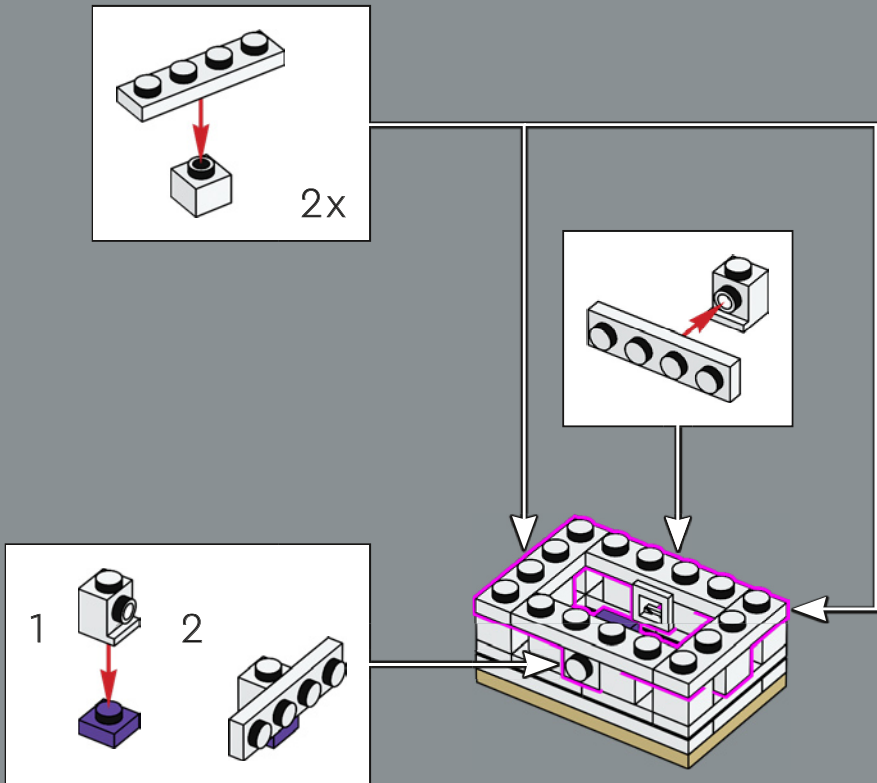

285

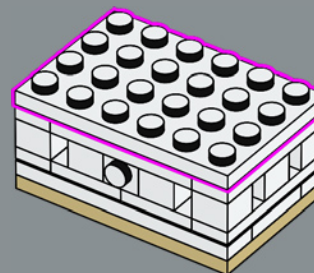

286

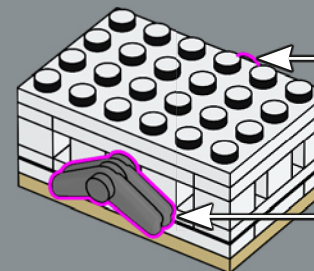
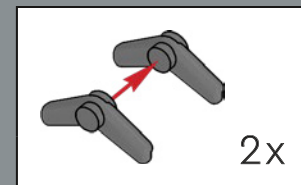

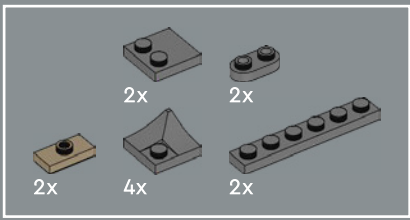

287

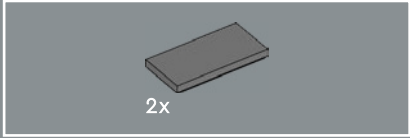
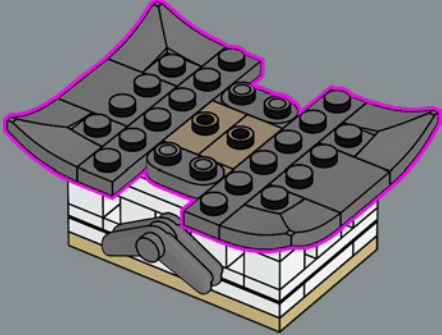

288

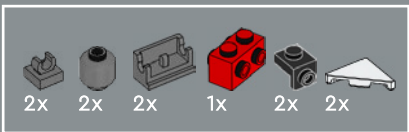
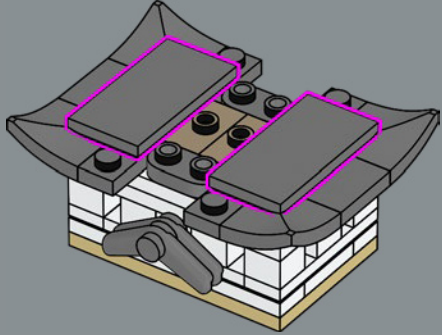

289

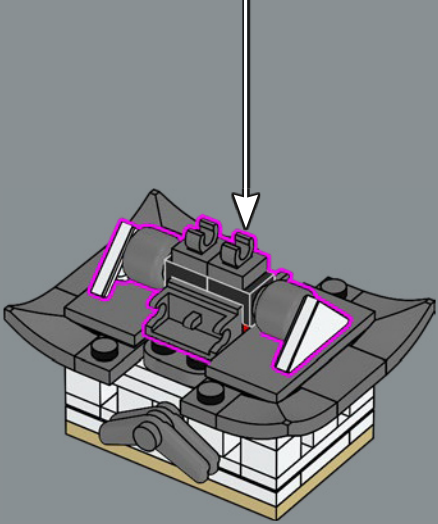
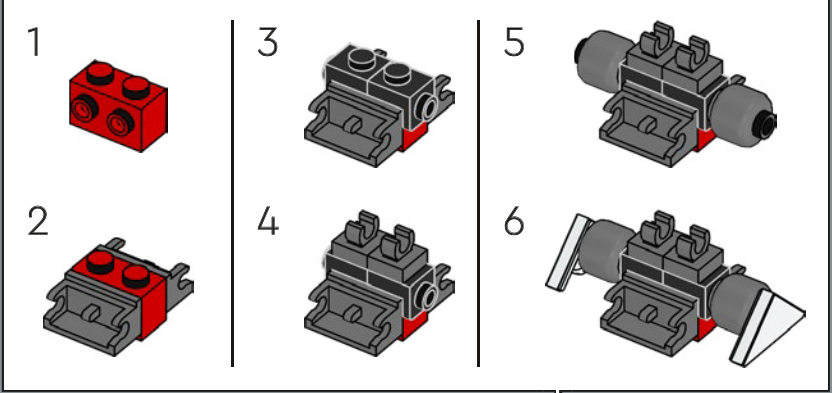

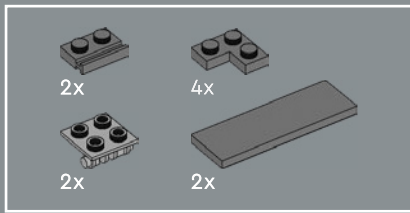

290

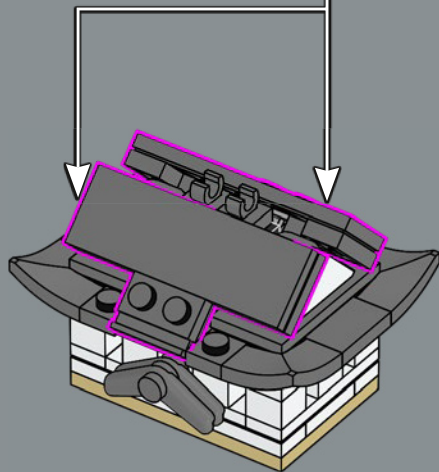
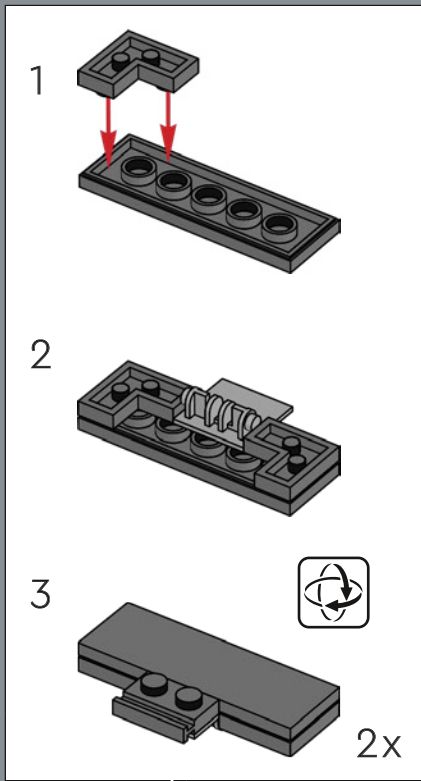

291

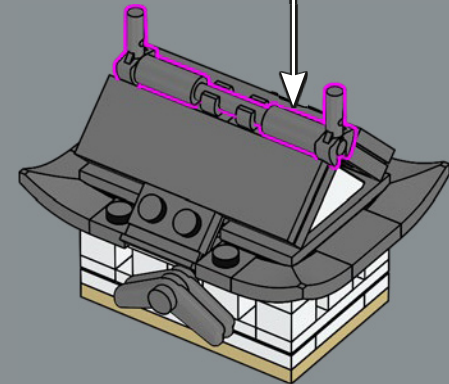
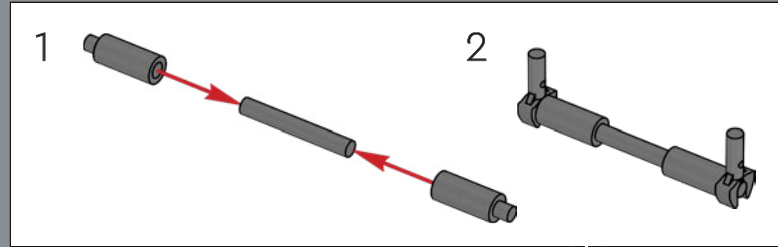

Las tejas del tejado de la torre principal se sustituyeron durante la restauración de 2009-2015. Las nuevas tejas, más finas, pesan 0,75 kg menos que las antiguas, ¡por lo que el tejado completo se aligeró en más de 45 t tras la sustitución!

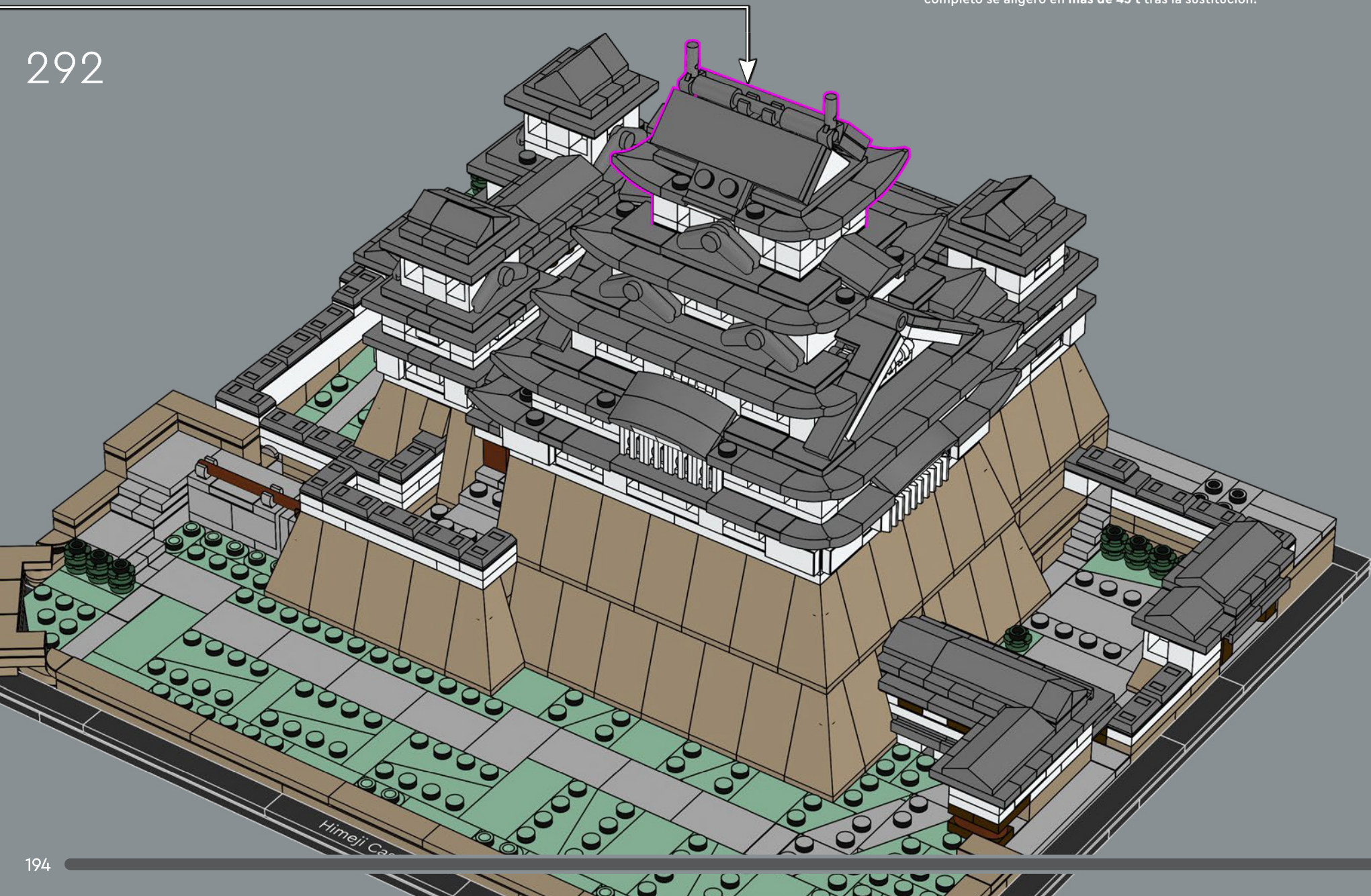

3x

3x

293

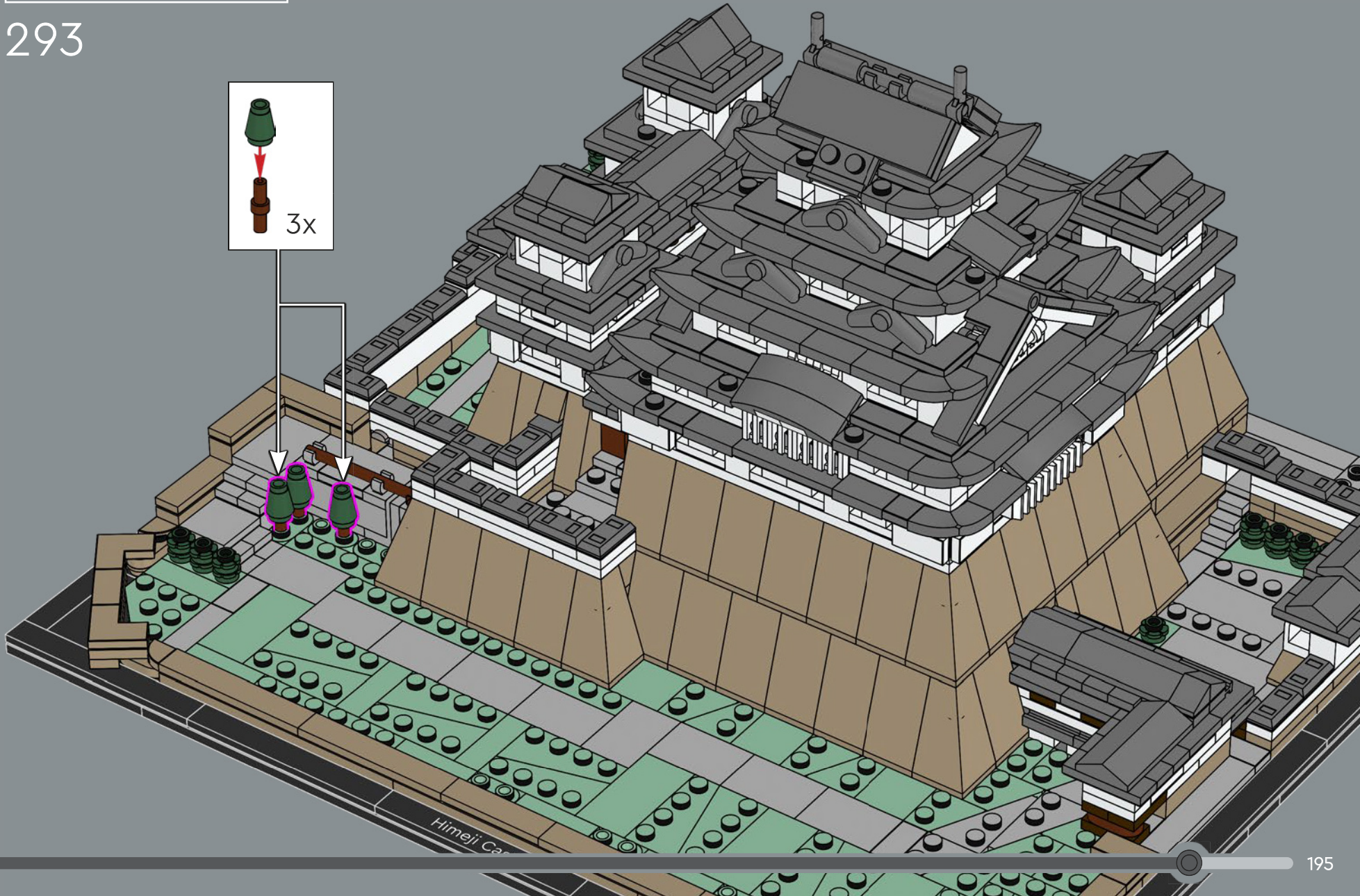
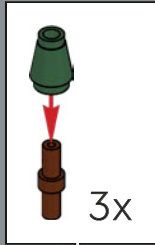



294

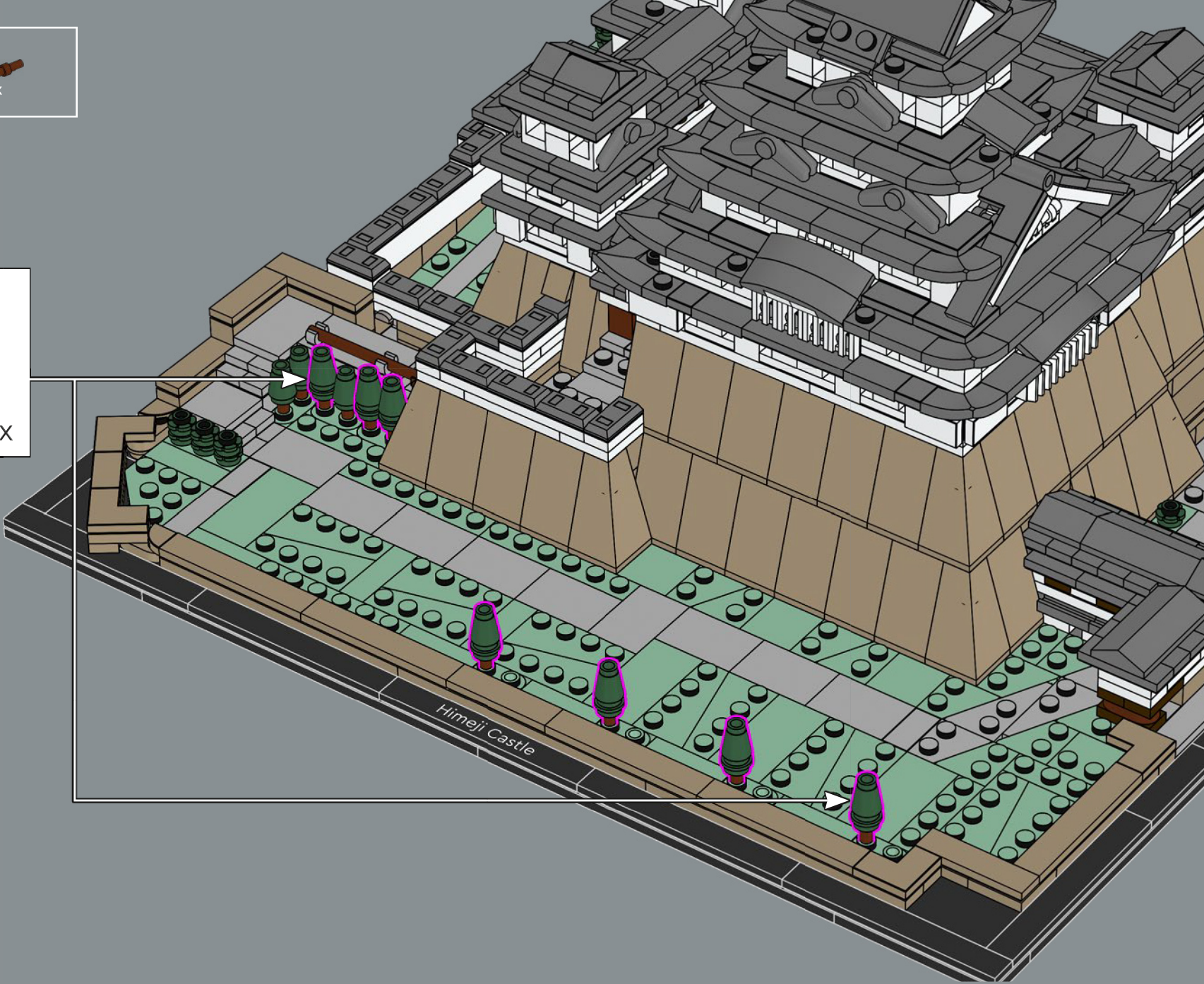
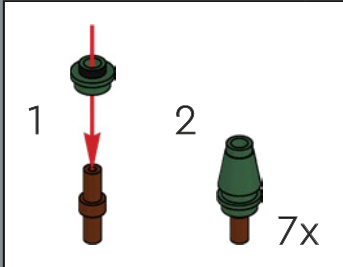

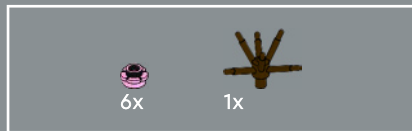

295

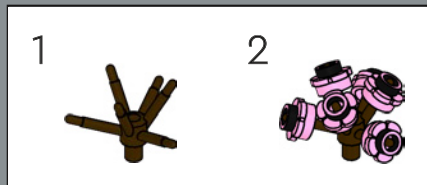

3x

296

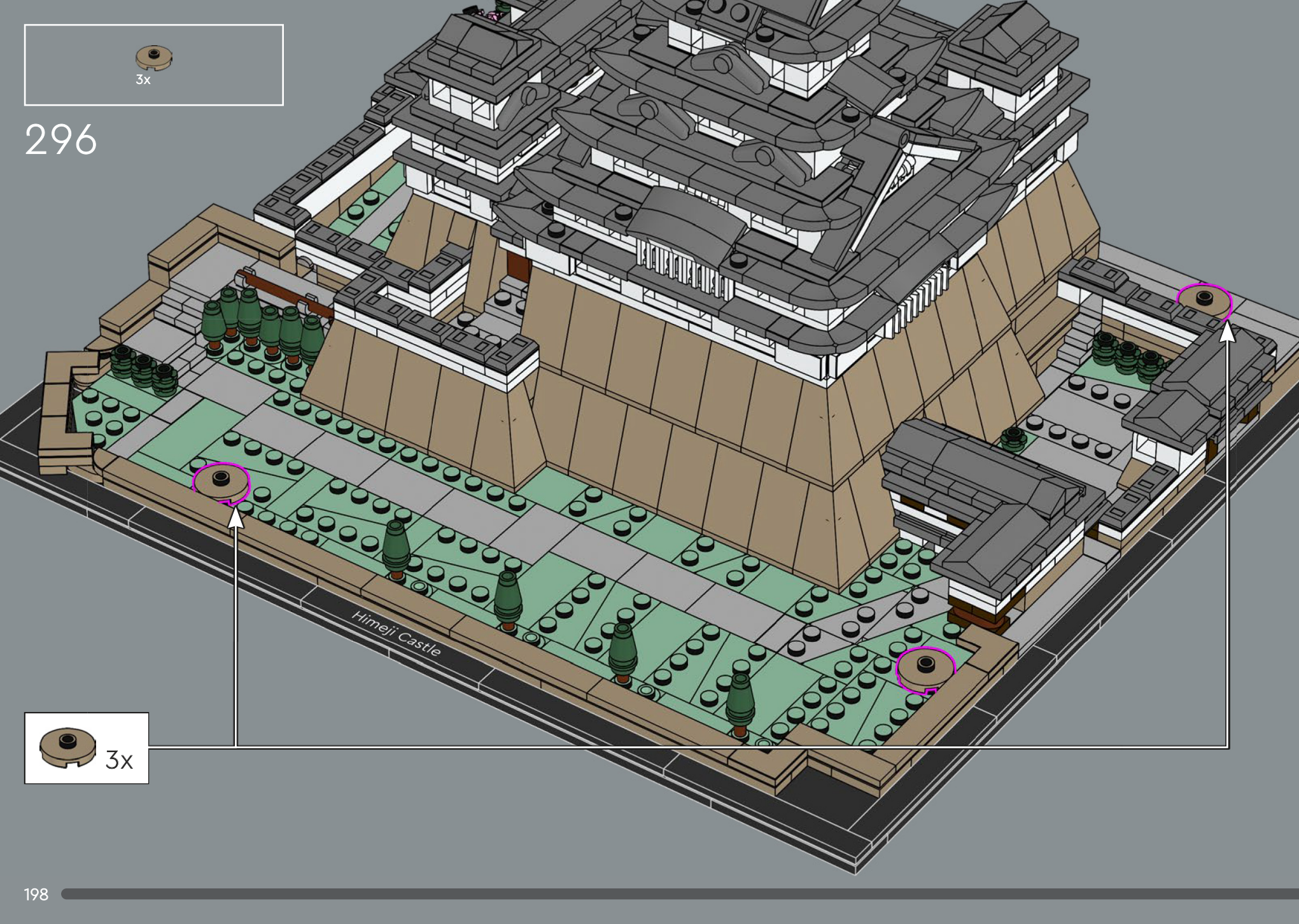

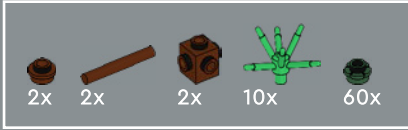
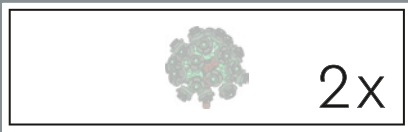

297

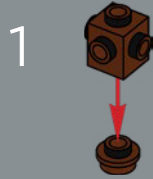
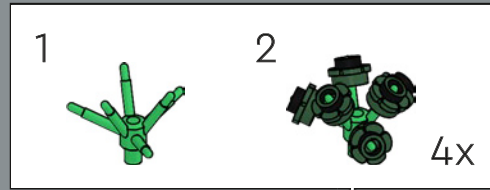
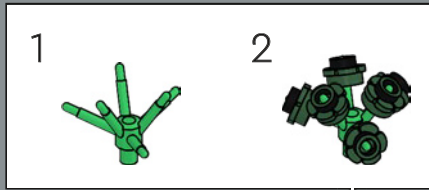



298

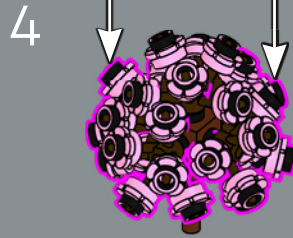
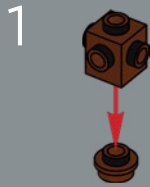
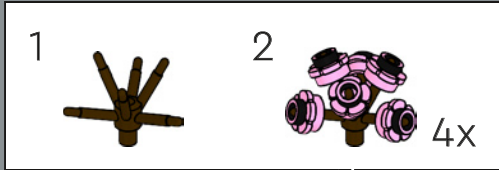
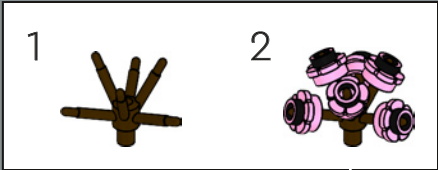



Himeji Castle

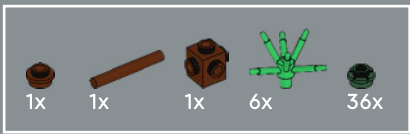

299

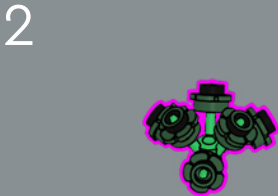
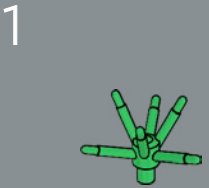
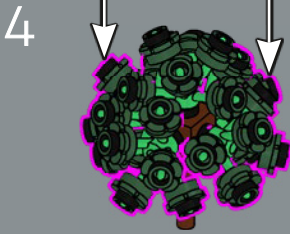
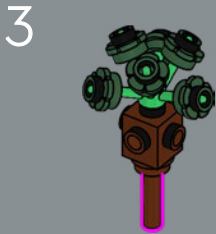
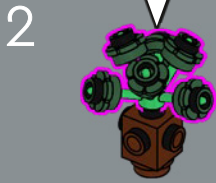
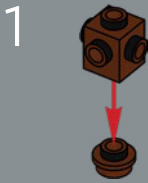
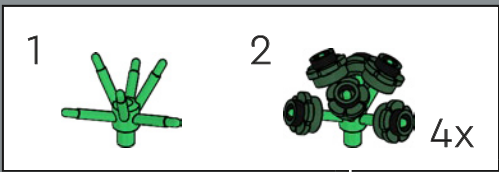
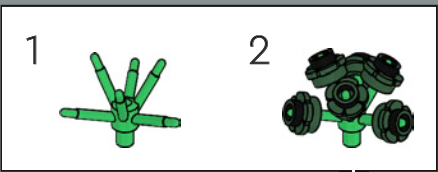

El Castillo de Himeji es conocido también como Castillo de la Garza Blanca, pues recuerda a una de estas majestuosas aves a punto de echar a volar.

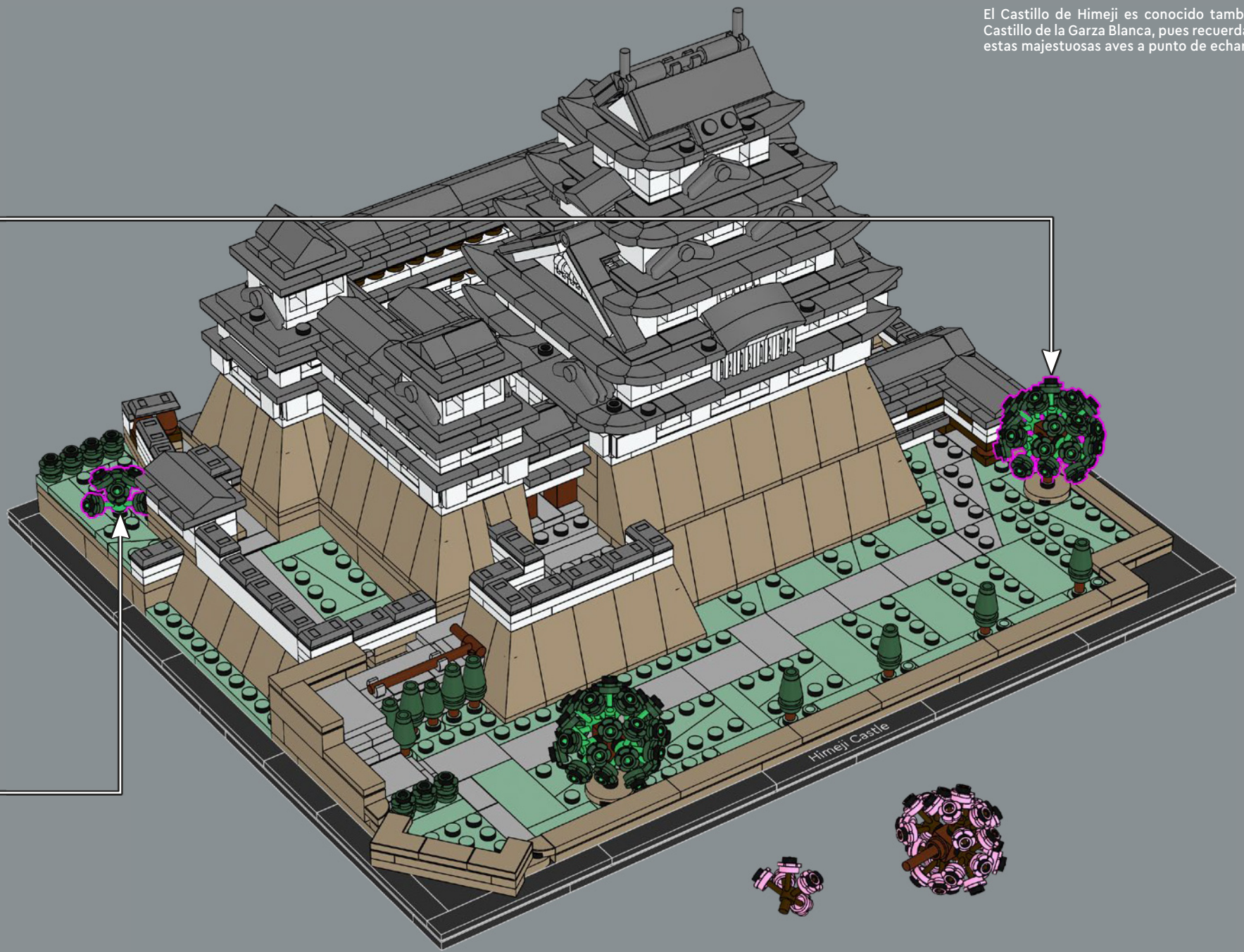

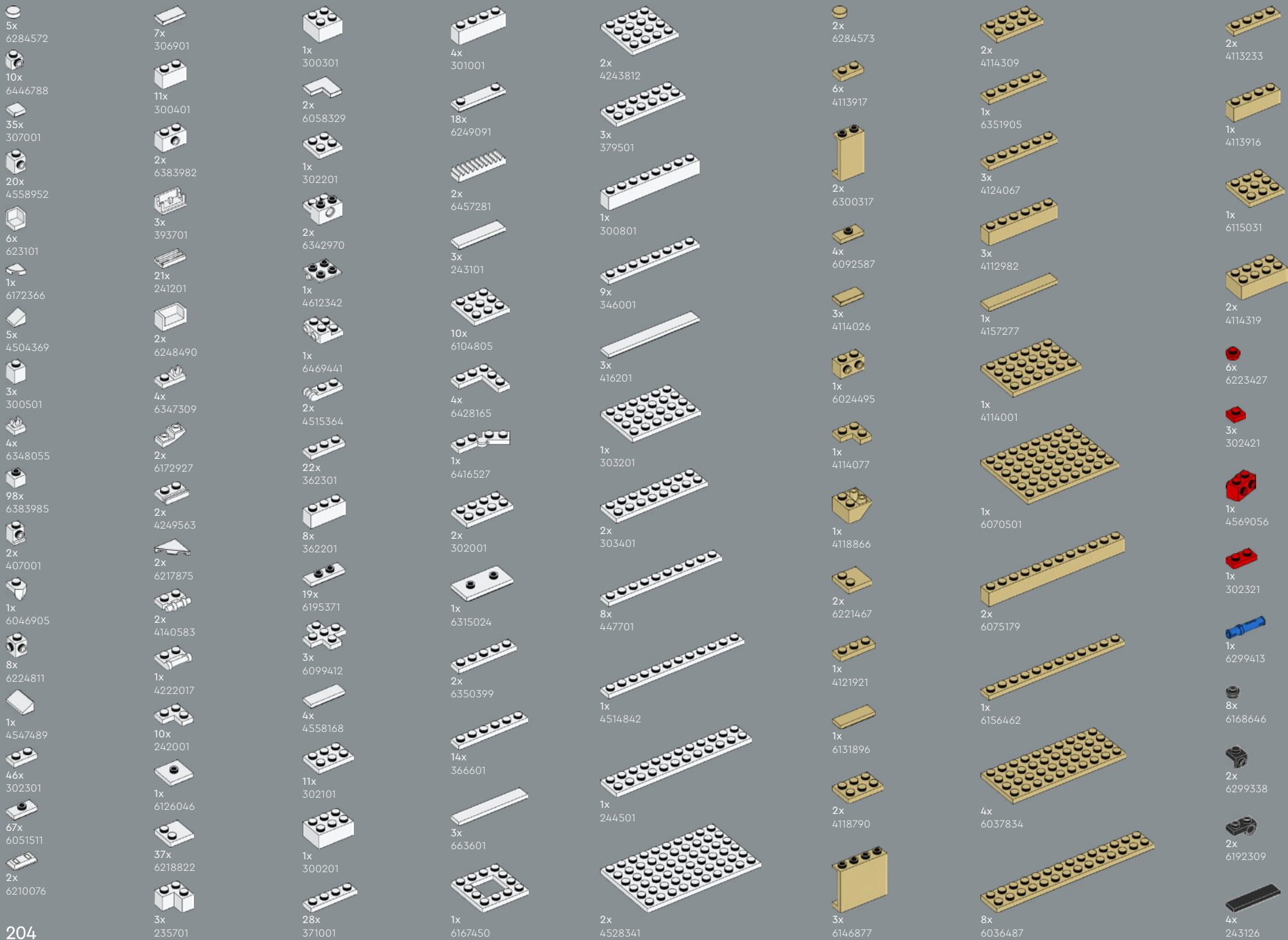



- 1x 6126082
- 1x 4211397
- 2x 4211349
- 1x 4211413
- 4x 4211881
- 1x 6438836
- 12x 4558169
- 12x 6211969
- 3x 4211429
- 16x 6171894
- 2x 4211356
- 5x 6257593
- 2x 4211445
- 5x 4560183
- 2x 4211395
- 1x 4211385
- 2x 4211549
- 4x 4211795
- 5x 4211481

- 1x 4211407
- 4x 4211408
- 6x 4211405
- 6x 4662161
- 4x 6058221
- 6x 6452882
- 1x 6252667
- 2x 6226792
- 1x 6223039
- 36x 6212501
- 4x 6388120
- 4x 4529240
- 2x 6439040
- 1x 4211407
- 4x 4211408
- 6x 4211405
- 4x 6058221
- 6x 6452882
- 1x 6252667
- 2x 6226792
- 1x 6223039
- 36x 6212501
- 4x 6388120
- 4x 4529240
- 2x 6439040

- 2x 6192569
- 2x 6395635
- 4x 4210848
- 9x 4210719
- 2x 6344022
- 6x 4504378
- 2x 6199549
- 2x 6221607
- 4x 6388119
- 1x 4226221
- 6x 4567887
- 29x 6331866
- 20x 6092572
- 12x 4211063
- 6x 4211052
- 2x 4211066
- 2x 4211135

- 3x 6000606
- 9x 4543086
- 20x 6446785
- 1x 6310596
- 12x 6126083
- 6x 6446786
- 1x 4211094
- 43x 6309059
- 2x 4210702
- 18x 6247784
- 1x 6232193
- 21x 6447212
- 4x 4210635
- 1x 4211055
- 60x 6343852
- 8x 4568734

- 1x 4211043
- 3x 6187008
- 4x 4211053
- 3x 4648256
- 2x 6039176
- 41x 6307616
- 6x 4560184
- 3x 4211127
- 10x 6189120
- 4x 4210651
- 2x 4211056
- 2x 6321746
- 1x 6230281

- 2x 4210998
- 1x 4211008
- 1x 4210997
- 1x 4211061
- 2x 6133611
- 1x 6000970
- 1x 6231376
- 2x 6215447
- 3x 6093529
- 25x 6315780
- 3x 6259071
- 4x 6194729
- 3x 4519970



 [LEGO.com/service](https://www.LEGO.com/service)



YOU COULD WIN



YOU COULD WIN

Your feedback will help shape the future development of this product series.

Visit:

DU KÖNNTEST GEWINNEN

Dein Feedback trägt zur Weiterentwicklung dieser Produktreihe bei.

Geh auf:

VOUS POURRIEZ GAGNER

Vos commentaires nous aideront à concevoir les futurs produits de cette gamme.

Visitez :

POTRESTI VINCERE TU

La tua opinione ci aiuterà a migliorare la creazione futura di questa linea di prodotti.

Visita:

PUEDES GANAR

Tu opinión contribuirá al futuro de esta serie de productos.

Visita:

轻松获奖

您的反馈将有助于我们在今后改进本产品系列。

请访问:

LEGO.com/productfeedback

You also have the chance to win a LEGO® set.

Terms and conditions apply.*

Außerdem hast du die Chance, ein LEGO® Set zu gewinnen.

Es gelten die Teilnahmebedingungen.*

Vous pourriez également gagner un ensemble LEGO®.

Des conditions s'appliquent.*

Hai anche la possibilità di vincere un set LEGO®.

Termini e condizioni sono applicabili.*

También tienes la oportunidad de ganar un set LEGO®.

Aplican términos y condiciones.*

您还有机会赢取乐高®套装。

条款和条件适用。*

*LEGO.com/productfeedback-terms

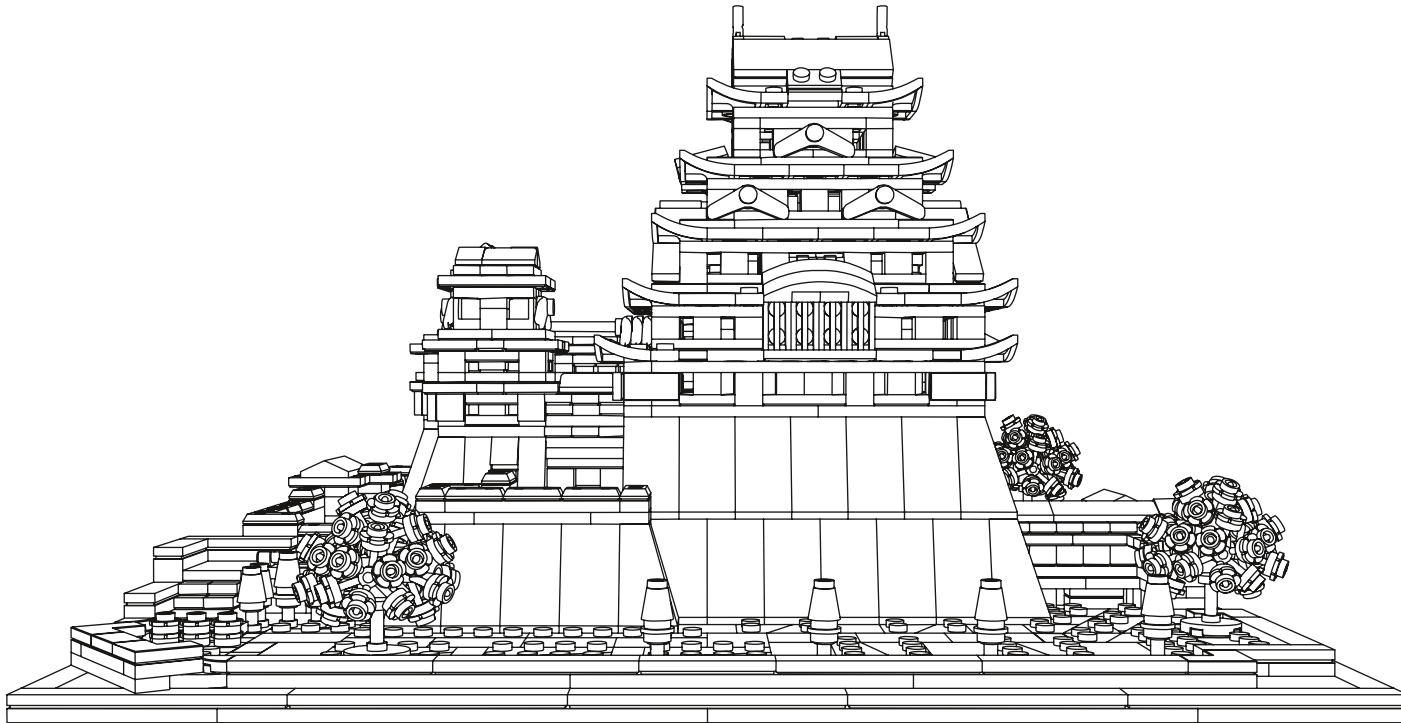

LEGO and the LEGO logo are trademarks of the LEGO Group. ©2023 The LEGO Group.

Adam Reed Tucker is the co-developer of the LEGO® Architecture product line.